

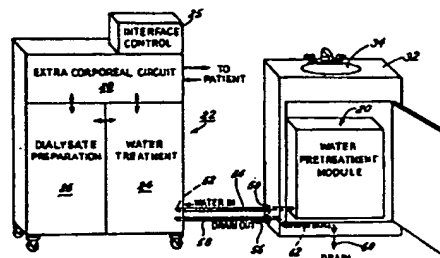

INTERNATIONAL APPLICATION PUBLISHED UNDER THE PATENT COOPERATION TREATY (PCT)

<p>(51) International Patent Classification ⁶ : B01D 17/00, 17/09, 17/12, 24/46, 24/48, 35/18, 36/00, 36/04, 37/00, 41/00, 61/00, 61/08, 61/24, 61/26, 61/28, 61/30, 61/32, 63/00, 65/00, 65/02, 65/08, 65/10, 71/00, A61L 2/00, 2/24, A61M 1/14, B01F 1/00, 3/00, B08B 3/00, 9/00, B67C 9/00, G06F 3/00, G08B 29/00, G08C 19/00, G09F 3/00</p>	<p>A1</p>	<p>(11) International Publication Number: WO 96/25214 (43) International Publication Date: 22 August 1996 (22.08.96)</p>
<p>(21) International Application Number: PCT/US96/01885 (22) International Filing Date: 9 February 1996 (09.02.96) (30) Priority Data: 08/388,275 13 February 1995 (13.02.95) US (60) Parent Application or Grant (63) Related by Continuation US 08/388,275 (CIP) Filed on 13 February 1995 (13.02.95) (71) Applicant (for all designated States except US): AKSYS, LTD. [US/US]; Suite 300, 1113 South Milwaukee Avenue, Libertyville, IL 60048 (US). (72) Inventors; and (75) Inventors/Applicants (for US only): KENLEY, Rodney, S. [US/US]; 816 Fair Way, Libertyville, IL 60048 (US).</p>	<p>MATTHEWS, Dawn [US/US]; 8 Hawley Court, Grayslake, IL 60030 (US). WILKERSON, Douglas, L. [US/US]; 4146 Kenwood Avenue, Gurnee, IL 60031 (US). TREU, Dennis, M. [US/US]; 17904 Pond Ridge Circle, Gurnee, IL 60031 (US). PETER, Frederick, H., Jr. [US/US]; 1237 Yorkshire Lane, Barrington, IL 60010 (US). BROSE, Tom, L. [US/US]; 17556 West Robert Court, Gurnee, IL 60031 (US). BELL, Eric [US/US]; 755 A Donna Court, Wheeling, IL 60090 (US). FELDSEIN, Thomas, M. [US/US]; 1397 Wyndham Circle #201, Palatine, IL 60067 (US). PAWLAK, Kenneth, E. [US/US]; 429 Appleton Drive, Vernon Hills, IL 60061 (US). WALKER, Donald, C. [US/US]; 233 East Walker Place, Mundelein, IL 60060 (US). MINNS, H., Gordon [US/US]; P.O. Box 20147, Jackson, WY 83001 (US). ADOLF, Wayne, F. [US/US]; 1300 North Santee Lane, Mount Prospect, IL 60056 (US). (74) Agent: FAIRHALL, Thomas, A.; Banner & Allegretti, Ltd., Ten South Wacker Drive, Chicago, IL 60606 (US). (81) Designated States: AL, AM, AT, AU, AZ, BB, BG, BR, BY, CA, CH, CN, CZ, DE, DK, EE, ES, FI, GB, GE, HU, IS, JP, KE, KG, KP, KR, KZ, LK, LR, LT, LU, LV, MD, MG, MK, MN, MW, MX, NO, NZ, PL, PT, RO, RU, SD, SE, SG, SI, SK, TJ, TM, TR, TT, UA, UG, US, UZ, VN, ARIPO patent (KE, LS, MW, SD, SZ, UG), European patent (AT, BE, CH, DE, DK, ES, FR, GB, GR, IE, IT, LU, MC, NL, PT, SE), OAPI patent (BF, BJ, CF, CG, CI, CM, GA, GN, ML, MR, NE, SN, TD, TG).</p> <p>Published With international search report. With amended claims.</p>	

(54) Title: MODULAR HOME DIALYSIS SYSTEM



(57) Abstract

A machine for conducting dialysis of body fluids of a patient is disclosed. The machine (22) includes integral water preparation and treatment (24), dialysate preparation (26), and extracorporeal circuit modules (28), under computer control from a patient interface and control module (25). A water pretreatment module (20) with a temperature-controlled mixing valve (36), an integral water filtration and conditioning unit (40) and a pressure relief valve (38) with integral water sample removal port (78) supplies water to the machine (22). Methods of disinfecting and cleaning dialysis machine (22), a method of conducting dialysis, a method of automatically testing the integrity of a dialysate filter and/or a dialyzer, and a method of approximating the sodium clearance of a dialyzer are also disclosed.

FOR THE PURPOSES OF INFORMATION ONLY

Codes used to identify States party to the PCT on the front pages of pamphlets publishing international applications under the PCT.

AM	Armenia	GB	United Kingdom	MW	Malawi
AT	Austria	GE	Georgia	MX	Mexico
AU	Australia	GN	Guinea	NE	Niger
BB	Barbados	GR	Greece	NL	Netherlands
BE	Belgium	HU	Hungary	NO	Norway
BF	Burkina Faso	IE	Ireland	NZ	New Zealand
BG	Bulgaria	IT	Italy	PL	Poland
BJ	Benin	JP	Japan	PT	Portugal
BR	Brazil	KE	Kenya	RO	Romania
BY	Belarus	KG	Kyrgyzstan	RU	Russian Federation
CA	Canada	KP	Democratic People's Republic of Korea	SD	Sudan
CF	Central African Republic	KR	Republic of Korea	SE	Sweden
CG	Congo	KZ	Kazakhstan	SG	Singapore
CH	Switzerland	LI	Liechtenstein	SI	Slovenia
CI	Côte d'Ivoire	LK	Sri Lanka	SK	Slovakia
CM	Cameroon	LR	Liberia	SN	Senegal
CN	China	LT	Lithuania	SZ	Swaziland
CS	Czechoslovakia	LU	Luxembourg	TD	Chad
CZ	Czech Republic	LV	Latvia	TG	Togo
DE	Germany	MC	Monaco	TJ	Tajikistan
DK	Denmark	MD	Republic of Moldova	TT	Trinidad and Tobago
EE	Estonia	MG	Madagascar	UA	Ukraine
ES	Spain	ML	Mali	UG	Uganda
FI	Finland	MN	Mongolia	US	United States of America
FR	France	MR	Mauritania	UZ	Uzbekistan
GA	Gabon			VN	Viet Nam

- 1 -

MODULAR HOME DIALYSIS SYSTEM

5

FIELD OF THE INVENTION

The invention relates to dialysis machines, their constituent components and subsystems, and their methods of operation. The dialysis machine of the present invention is particularly suitable for use outside of a conventional dialysis clinic, e.g., in a home, self-care clinic, or nursing home environment.

BACKGROUND OF THE INVENTION

Dialysis, including hemodialysis and peritoneal dialysis, is a treatment mode for patients that suffer from inadequate kidney function. In hemodialysis, blood is pumped from the patient's body through an extracorporeal artificial kidney (dialyzer) circuit, where blood-borne toxins and excess water are filtered out of the blood through a semipermeable membrane into an electrolyte (dialysate) medium. A commonly used form of dialyzer comprises a large number of semipermeable hollow fiber membranes, which greatly increase the surface area available for dialysis to facilitate diffusion and convection across the membranes.

Existing dialysis systems typically consist of two parts; one comprising an extracorporeal blood flow circuit and the other comprising a dialysate circuit or flow path. Typically, the entire blood flow circuit is disposable and comprises: 1) an arterial and venous fistula needle, 2) an arterial (inflow) and venous (outflow) tubing set, 3) a dialyzer, 4) physiologic priming solution (saline) with infusion set, and 5) an anticoagulant, such as

- 2 -

heparin or sodium citrate with infusion set. The arterial needle accesses blood from the patient's blood access site and is connected to the arterial blood tubing set, which conveys blood to the dialyzer.

5 The arterial line typically comprises: a pumping segment with interfaces to a rotary or peristaltic blood pump on the hemodialysis machine, pressure monitoring chambers including tubing which interfaces to pressure transducers on the machine to monitor the pressure pre-pump and/or post pump, inlet ports for saline and anticoagulant, and one or more injection sites for drawing blood or injecting drugs.

10 The dialyzer itself typically comprises a case which encloses a bundle of hollow fibers having a semi-permeable membrane. The blood is circulated on the inside of the hollow fibers while dialysis solution is circulated on the outside, so that the two never come into direct contact. Toxins diffuse out of the blood and into the dialysis solution owing to the concentration gradient. Excess water in the patient's blood enters the dialysate as a result of a pressure gradient. The membrane is made from cellulosic derivatives or synthetic
15 polymers.

The venous line and needle carry the newly dialyzed blood away from the dialyzer and back into the patient's circulatory system. The venous set is comprised of a pressure monitoring chamber with tubing leading to another pressure transducer in the machine, injection sites, and a segment of tubing which interfaces to an air detection assembly in the
20 machine in order to prevent air emboli from passing to the patient.

Dialysis solution is typically prepared continuously on-line in present-day machines by combining water which has first been purified by a separate water treatment system and liquid concentrates of electrolytes. Over the past decade the dialysate concentrates have

- 3 -

evolved from a single formulation which contained acetate as the physiologic buffering agent for the correction of circulatory acidosis, to two containers where bicarbonate replaces acetate as the buffering agent. Two proportioning pumps are required, the first to mix the bicarbonate concentrate with water and the second to proportion this mixture with the concentrated electrolytes to achieve the final, physiologically compatible solution.

Most contemporary hemodialysis machines continuously monitor the pressure at the blood outlet side of the dialyzer by way of the pressure transducers connected to the blood sets and also in the dialysate circuit. Microprocessors calculate an estimated transmembrane pressure (TMP) which correlates to the amount of water transmission through the membrane.

These machines may also have means of measuring the amount of dialysis solution entering and leaving the dialyzer, which allows the calculation of net water removal by ultrafiltration from the patient. By electronically comparing the amount of water entering or leaving the blood with the transmembrane pressure, the system is able to control actively the water removed from the patient to a desired target previously programmed into the system. When low-water-transmission cellulosic membranes are employed, negative pressure must be generated on the dialysate side of the membrane by the machine in order to accomplish sufficient water removal. Because suction may be applied to the dialysate as it transits the dialyzer, it must first be placed under a greater vacuum in a degassing chamber so that air bubbles are not generated within the dialyzer that would cause errors in the calculation of ultrafiltration by the sensors and also reduce the efficiency of the dialyzer. On the other hand, when high-water-transmission, synthetic membranes are used, it is frequently necessary to apply positive pressure on the dialysate side to control the otherwise excessive rate of ultrafiltration.

- 4 -

The majority of dialyzers are reused in the United States. The trend worldwide is towards reusing dialyzers. There are numerous procedures for reusing dialyzers both manually and automatically. In centers, special machines for simultaneous multiple dialyzer reprocessing are used.

5 These procedures must be conducted in a biohazard environment since there is always the potential for exposure to human blood, and hepatitis and AIDS are relatively prevalent in the dialysis population. Also, the OSHA and EPA stipulate various working environment regulations owing to the hazardous sterilizants and cleaning agents used.

10 Reprocessing of dialyzers and lines may be performed on the dialysis machine. The Boag patent, U.S. No. 4,695,385, discloses a cleaning apparatus for dialyzer and lines. The device is permanently or semipermanently connected into the dialysis machine system.

15 Finally, the dialysis machine fluid circuits must be periodically cleaned and disinfected. There are two reasons for this. The first relates to the fact that the dialysate has historically not been sterile. From the very beginning of dialysis as a therapy, the dialyzer membrane has been relied upon to be a sterile barrier between dialysate and blood. This is
20 certainly true for whole bacteria, but concern has been growing over the past several years that with the use of synthetic membranes and their more porous structure, endotoxins, or components thereof, may by permeating these membranes and activating inflammatory processes within the patients. When dialysate containing bicarbonate is used, calcium carbonate inevitably precipitates and accumulates on the plumbing and must be dissolved with an acidic solution.

Historically, many artificial kidneys have utilized a proportioning system for producing dialysis solution and delivering it into a hemodialyzer. In the early years of

- 5 -

hemodialysis only a so-called tank or batch system was used. The machine was provided with a large tank where purified water was premixed with dry chemicals to make dialysis solution, which was warmed and recirculated through the dialyzer dialysate path. Bicarbonate was used as a buffer; CO₂ was bubbled through the solution, or lactic acid was added to the solution to prevent calcium/magnesium carbonate precipitation. With inefficient dialyzers, a dialysis time of 12 hours or more was used. Warm dialysate was an excellent culture medium for bacterial growth. Long dialysis treatment time magnified the problem. To overcome this problem a proportioning system was designed whereby the solution was being prepared *ex tempore* from purified water and concentrate. The concentrate contained acetate as the physiologic buffering agent because bicarbonate tended to precipitate with calcium and magnesium if present in the same concentrate.

As of the mid-1990's there are approximately 180,000 patients on dialysis in the United States, almost 500,000 worldwide. Most of them dialyze in hemodialysis centers and approximately 17% are on home peritoneal dialysis with less than 3% on home hemodialysis. Typically, in-center hemodialysis is performed three times per week for between two and four hours. The more physiologically desirable four times per week dialysis sessions are used only with patients with severe intolerance to three times weekly dialysis, generally due to cardiovascular instability. Home hemodialysis is also typically performed three times weekly.

Three dialysis sessions per week is considered a standard schedule in the majority of dialysis centers, yet there is considerable scientific evidence that more frequent dialysis for shorter periods of time is more beneficial. Whereas the normal human kidneys function continuously to produce gradual changes in total body fluid volume and metabolic waste

- 6 -

levels, three times weekly dialysis schedules produce abnormal physiological fluctuations which yield considerable stress on the patient's systems.

The amount of time consumed travelling to and from the center, and the dialysis procedure itself, is mostly tolerable for the patients who perform three sessions per week. Consequently, only those patients who experience unbearable intolerance of body fluid volume fluctuations, and the associated symptoms, agree to more frequent (four times weekly) dialysis sessions. For home dialysis patients, more frequent dialysis than three times per week would mean more stress on the relatives who help with set-up and who monitor the patient and on the patient who does most of the work for set-up, tear-down, and cleaning. Accordingly, the use of home hemodialysis on a frequent basis (four or more times per week) has, at least heretofore, not been widely practiced.

Many patients have enormous difficulties achieving a "dry" body weight if they accumulate three, four, or more kilograms of fluid between dialysis treatments. Some patients, especially those with heart disease, poorly tolerate even a two kilogram fluid weight gain; they are short of breath before dialysis, have muscle cramps and hypotension during dialysis, and feel "washed out" and are extremely weak, needing several hours to "equilibrate" and become functional. Serum concentration of highly toxic potassium frequently reaches dangerous levels (more than seven mEq/L), particularly preceding the first dialysis after a longer interval (weekend). To mention only a few others, calcium and pH are too low before dialysis or too high after dialysis in many patients. Empirically, in many hemodialysis units, these patients are placed on a four times weekly dialysis schedule.

Historically, artificial kidney systems were developed according to the assumption that the machine should be very sophisticated and automated during dialysis and less so for

- 7 -

preparation and cleansing. This assumption was valid for long and infrequent dialysis sessions where compared to the total dialysis time the time for setup and cleansing of the machines was relatively short.

5 More efficient dialyzers were eventually designed, and time of a single dialysis session gradually decreased to 8, 6, 5, 4, 3, and even 2 hours. With very efficient dialyzers, acetate was delivered to the patient in excess of the body ability to metabolize it, which caused cardiovascular instability. An answer to this problem was to return to bicarbonate as a buffer but within an overall design of proportioning system. Because of chemical incompatibility of bicarbonate with calcium and magnesium, two proportioning pumps are
10 required, the first to mix the bicarbonate concentrate with water and the second to proportion this mixture with the concentrated electrolytes to achieve the final, chemically compatible solution. However, a short daily dialysis session of 1-3 hours offers a possibility of abandoning the proportioning system.

If short daily hemodialysis is done in a dialysis clinic, the travel time, inconvenience
15 and expense incurred by the patient increases dramatically. If such a practice is adopted by a large number of the center's patients, the staff at the treatment center is also burdened. Additionally, the dialysis facility's capacity for performing this number of incremental treatments would have to be increased, requiring capital expansion. Consequently, the patient's home is a desirable location for this treatment modality.

20 U.S. Patent No. 5,336,165 to Twardowski describes techniques for overcoming many of the problems associated with conventional dialysis devices. This patent describes a hemodialysis system which has a built-in water treatment system; automatic formulation of batch dialysis solution; automated reuse; automated set-up; automated cleaning and

- 8 -

disinfection of blood and dialysate circuits; and reduction in storage space by utilizing dry and concentrated chemical reagents. This system is suitable for home dialysis.

The failure of home hemodialysis to achieve the widespread popularity is due partly to the failure in the art to produce a user-friendly, efficient, and affordable home hemodialysis system that relieves the patient and the patient's family from time-consuming and tedious pre-treatment and post-treatment set-up and teardown of the home hemodialysis equipment. The present inventive machine remedies this situation, offering patients a hemodialysis system particularly suitable for short daily hemodialysis in the home environment.

The present invention relates to a modular hemodialysis machine especially suitable for use in the home environment that provides for a cost-effective, transportable, simple and highly reliable home hemodialysis system that automates substantially the entire process and requires a minimum of patient input and labor. By substantially reducing the labor intensity and disposables cost associated with prior art home hemodialysis treatment equipment, the present invention is intended to open up the availability of short daily hemodialysis in the home environment to a larger pool of hemodialysis patients. These patients, by practicing the present invention, can avail themselves of this treatment modality, which has proven to yield outstanding clinical benefits, without having the inconvenience of travel to remote treatment centers.

- 9 -

SUMMARY OF THE INVENTION

The reader is directed to the pending claims, wherein numerous embodiments of the present invention are defined with particularity. In an overall aspect, the present invention is a hemodialysis machine with integral water preparation, dialysate preparation and extracorporeal circuit modules under central computer control from a patient interface and control module. A water pretreatment module for the machine is installed in the home and connected to household hot and cold water pipes. The water pretreatment unit contains a temperature-controlled mixing valve, water filtration, carbon and possibly other purifying or conditioning agents depending on the composition and nature of the local water supply.

Also contained is an integral pressure relief valve with water sample removal port for sampling the treated water for any residual chlorine or chloramines. The water pre-treatment unit supplies the machine with treated water at a temperature of at or below approximately 30 degrees C and at a substantially constant pressure.

The dialysate preparation module contains a substantially noncompliant dialysate preparation tank with a novel and advantageous chemical addition and dispersion subsystem mounted to the tank which automatically adds the dialysate chemicals to the dialysate preparation tank. The chemical addition and dispersion subsystem includes dialysate chemicals in bottles with machine-readable identifiers affixed to their exterior surface. If the patient installs the wrong chemical bottles to the addition and dispersion subsystem, an alarm is activated and the user is prompted to replace the bottle with the correct bottles.

The operation of the water treatment, dialysate preparation and extracorporeal circuit modules feature novel and advantageous process control methods to insure reliability and efficiency during the dialysis process. Automatic testing of the integrity of the ultrafiltration

- 10 -

system, the dialysate filter (or "ultrafilter/pyrogen filter"), the dialyzer, the extracorporeal circuit, the dialysate circuit and the clearance of the dialyzer prior to dialysis is performed. Further, calibration of key pressure sensors and the blood pump is performed automatically prior to dialysis to insure their accuracy. In order to accomplish these and other process control features, novel and advantageous subsystems, flow paths, and system subcomponents have been built into the design of the machine.

The machine further features a hot purified water disinfection process, without the use of disinfection chemicals, for the entire machine, including the water treatment module. The computer-controlled water disinfection process takes advantage of strategically placed thermistors in the flow paths of the machine to monitor water temperature and provide feedback control for the process. The system features a back-up chemical disinfection capability.

The result of these and other features of the invention is a highly efficient, robust, and user-friendly machine that requires a minimum of user involvement. As such, the machine is particularly suitable for use in a short, daily hemodialysis therapy regime. The entire machine also contains design features resulting in a transportable machine, making the machine particularly suitable for use outside of a traditional dialysis clinic, and in particular in a home, nursing home or self-care clinic environment. It will be further noted that many of the inventive process control techniques, subsystems and components of the machine are applicable (either directly or by slight modification) to other types of therapies besides hemodialysis, such as hemodiafiltration, hemofiltration and peritoneal dialysis.

These and many other aspects, features and advantages of the invention are explained in the following detailed description of the invention and the best mode known to the

WO 96/25214

PCT/US96/01885

- 11 -

inventors of practicing the invention.

BRIEF DESCRIPTION OF THE DRAWINGS

In the following detailed description of the presently preferred embodiments of the invention, reference will be made to the accompanying drawings, wherein like numerals in the drawings refer to like elements in the various views, and wherein:

5 FIG. 1 is a schematic block diagram of the overall system, showing the relationship between a water pretreatment module, a modular home dialysis machine and the patient;

 FIG. 2 is a detailed schematic diagram of the water pretreatment module of FIG. 1;

 FIG. 3A is a perspective view of the water filtration unit 40 of FIG. 2, showing the path of water through the water filtration unit;

10 FIG. 3B is a perspective view of a preferred secondary water filtration unit 84 of the water treatment module 24;

 FIG. 3C is sectional view of the secondary water filtration unit 84 of FIG. 3B, showing the flow of water through the unit;

 FIG. 4A is a cross-sectional view of the pressure relief valve 78 with integral sample removal port of FIG. 2;

15 FIG. 4B is a detailed view of the upper portion of the pressure relief valve 78 of FIG. 4A during removal of a sample from the valve;

 FIG. 4C is a perspective view of an alternative construction for the central member 146 of FIG. 4A;

20 FIG. 4D is a perspective view of the insert of FIG. 4A;

 FIG. 5 is a detailed schematic diagram of the water treatment module 24 of FIG. 1;

 FIG. 6 is a detailed schematic diagram of the hydraulic or dialysate preparation module 26 of FIG. 1;

- 13 -

FIGS. 7A-7E are several views of the chemical loading platform 250 of FIG. 6;

FIGS. 8A-8C are several views of the chemical applicator system 260 of FIG. 6;

FIG. 9A-9C are several isolated views of the mounting member 354 of the chemical applicator 260 of FIGS. 8A-8C;

5 FIGS. 10A-10F are several views of the chemical bottle 270 of FIG. 6;

FIG. 11A is a plan view of the noninvasive conductivity cell 426 of FIG. 6;

FIG. 11B is a plan view of an alternative noninvasive conductivity cell 426;

FIG. 11C is a plan view of an alternative noninvasive conductivity cell 218;

10 FIG. 12 is a sectional view of the chemical applicator and bottle of FIG. 6 during rinsing of the bottle;

FIG. 13 is a schematic diagram of the extracorporeal circuit module 28 of FIG. 1;

FIG. 14A-14B are several views of the noninvasive pressure sensor 500 of the extracorporeal circuit module 28 of FIG. 13, FIG. 14C is a sectional view of the diaphragm of FIG. 14A;

15 FIGS. 15A-15D are several views of a cassette-style debubbler for use in the extracorporeal circuit module 28 of FIG. 13;

FIG. 16 is a block diagram of the user interface and control module 25 of FIG. 1, showing its relationship to the various sensors and components of the machine;

FIG. 17 is a flow diagram of the sequence of steps of the operation of the machine;

20 FIG. 18 is a flow diagram of the sequence of events during the disinfect step of FIG. 17;

FIG. 19 is a flow diagram of the sequence of events during the prepare dialysate step of FIG. 17;

- 14 -

FIG. 20 is a flow diagram of the sequence of events during the initiate dialysis step of FIG. 17;

FIG. 21 is a flow diagram of the sequence of events during the dialyze step of FIG. 17, showing in particular the periodic backflush of the dialyzer 404 during dialysis;

5 FIG. 22 is a flow diagram of the sequence of events during the rinseback step of FIG. 17;

FIG. 23 is a flow diagram of the sequence of events during the clean and rinse step of FIG. 17;

10 FIG. 24A -24B are two views of a technique for securing silicone tubing such as that used in the present invention to a hardware component, such as, for example, a pump or valve;

FIG. 25A is a schematic diagram of the blood leak detector 428 of FIG. 13;

FIG. 25B is a diagram of the flow of signals in the blood leak detector of FIG. 25A;

15 FIG. 26 is a diagram of conductivity as a function of time measured by the conductivity sensor 426 during the clearance test 743 of FIG. 19;

FIG. 27A is an elevational view of the extracorporeal circuit module 28 of FIG. 13, with the dashed lines showing that the the arterial 432 and venous 492 blood lines connect to the ports 499, 497 respectively of a disinfection manifold when the dialysis session has been completed;

20 FIG. 27B is an elevational view of the extracorporeal circuit module 28 of FIG. 27A, with arterial and venous lines connected to the disinfection manifold ports 499, 497, the condition they would be in during disinfection of the machine;

FIG. 27C is an elevational view of the extracorporeal circuit module 28 of FIG. 27A,

- 15 -

with the arterial and venous lines connected to the patient, as they would be during dialysis;

FIG. 28 is a detailed perspective view of the ports 495, 497, 499 of the disinfection manifold 494 of FIG. 13, showing the connection of the ports with tubing from the dialysate preparation module 26;

5 FIGS. 29A-29C are several views of a male luer 550 of a tubing connection terminal for use with the disinfection manifold of FIG. 36, FIG. 29D is a sectional view of the male luer 550 of FIG. 29A engaging a female luer 559;

10 FIG. 30A is a perspective view of the male luer 550 of FIG. 29 shown prior to insertion of an outer piece 570 thereover, the male luer and outer pieces forming a unitary tubing connector;

 FIGS. 30B-30C are several view of the outer piece 570 of FIG. 30A;

 FIG. 30D is an elevational view and partially broken away of the tubing connector of FIG. 30A in an assembled contion;

15 FIGS. 30E-G are illustrations of alternative constructions of the connector of FIG. 30A;

 FIG. 30H is a perspective view of an alternative male luer of FIGS. 30G;

 FIG. 30I is a plan view of the male luer of FIG. 30H;

 FIGS. 30J and 30K are sectional views of the luer of FIG. 30H;

20 FIG. 31A-31C are several views of preferred design for the ports of the disinfection manifold 494 of FIGS. 13 and 28;

 FIG. 31D is a sectional view of the port of FIG. 31C with the tubing connector of FIG. 30D installed therein;

 FIG. 31E is a perspective view of the construction of FIG. 31D partially broken

- 16 -

away;

FIGS. 32A-432E are several views of the knob 641 of the port 499 of FIG. 31E;

FIG. 33 is an illustration of a hemofiltration with pre-dilution embodiment of the invention;

5 FIG. 34 is an illustration of a hemofiltration with post-dilution embodiment of the invention; and

 FIG. 35 is an illustration of a hemodiafiltration with post-dilution embodiment of the invention.

- 17 -

**DETAILED DESCRIPTION AND BEST MODE OF
PRACTICING THE INVENTION**

Referring to FIG. 1, a preferred embodiment of the overall inventive machine and system is shown in block diagram form. The modular dialysis machine 22 receives water from a water pretreatment module 20. The pretreatment module 20 and modular dialysis machine 22 are shown installed, for purposes of example and not limitation, in a patient's home environment. The primary functions of the water pretreatment module 20 are to provide preliminary treatment of water from a household water supply, to provide treated water at a predetermined warmed temperature and pressure to the dialysis machine 22, and to carry system drain and waste water from the dialysis machine 22 to a household drain. The dialysis machine 22 is preferably a moveable unit, mounted on wheels, that houses three functionally discrete modules: a water treatment module 24, a dialysate preparation or hydraulic module 26 and an extracorporeal circuit module 28. The patient in need of dialysis (not shown) is connected to the extracorporeal circuit module 28 in conventional fashion with two lines designated "arterial" and "venous".

The dialysis machine 22 further includes a patient interface and control module 25 including a display and a touch screen (or other patient input means, such as a keyboard or voice-activated system) connected to one or more central processing units. The interface and control module 25 exercises supervisory control over the operation of the system, displays the current status of the machine, prompts the user to input commands and information, receives data from the various sensors and other passive components of the system, records the data in memory, controls the operation of the active components of the machine (such as valves, pumps, heaters, etc.), alerts the patient to abnormal or failure conditions in the

- 18 -

machine with alarms or other indicators, calculates parameters relating the hemodialysis, and performs additional tasks as discussed in detail below. Additionally, the interface and control module 25 may be provided with additional hardware components to permit the machine 22 to send patient dialysis information during or after the treatment to a central
5 monitoring station electronically, such as by modem.

I. Water Pretreatment Module 20

Referring now to FIGS. 1 and 2, the water pretreatment module 20 is shown installed in a cabinet 32 under a sink 34 (FIG. 1). The water pretreatment module 20 could also be
10 a mobile unit, in which flexible lines connect the module 20 to the household hot and cold water. Referring in particular to FIG. 2, hot and cold water is tapped off a household water system and fed to a temperature-controlled mixing valve 36, where the water is mixed to maintain a constant temperature of 28 to 30 degrees C in the output line 37. A suitable temperature-controlled mixing valve is available from Grohe, part no. 34 448. The warm
15 water is passed through a water pressure regulator 38 past a manually operated valve 39 to a replaceable integral water filtration and treatment unit 40. A preferred pressure regulator 38 can be obtained from Norgren.

A preferred water treatment unit 40 is the ROPAK unit from Millipore, part no. MSPB00168. Referring to FIG. 3A, the water treatment unit 40 has a unitary housing 47
20 containing four chambers 49A-49D. The water enters the chamber 49A via water inlet 41A. Chamber 49A is loaded with a particle filtration agent 42 that filters the water for particulate matter. After passing through the particulate agent 42, the water is passed through a second chamber 49B and a third chamber 49C loaded with a carbon filtration agent 44 which

- 19 -

removes organic material and dissolved gasses from the water. The water then passes into a fourth chamber 49D containing a polyphosphate water conditioning agent 43 and passes through the polyphosphate water conditioning agent and out the outlet 45A. The columns or chambers in the unit 40 can be preconfigured as necessary to meet the requirements of
5 local conditions.

Water is sent out of the water filtration unit 40 in line 46 and sent to a pressure relief valve 78 with an integral port for manual removal of samples of water to test for the presence of chlorine or chloramines in the water in the line 46. An outlet 50 directs the flow of water from the water pretreatment module 20 to a water inlet 52 in the dialysis machine
10 22 via a flexible hose 54. The water pretreatment module 20 has a drain inlet 56 that receives effluent from the dialysis machine 22 via flexible hose 58, and sends such effluent through a drain line 62, past check valve CV3 to a household drain 60. It may be advisable to switch input and output hoses 54, 58 periodically to avoid buildup of any organic matter in the input hose 54, which might occur since the water going to the machine normally
15 contains no chlorine and the effluent will be hot at certain points in time.

The provision of a temperature-controlled mixing valve 36 to mix household hot and cold water offers numerous advantages. The water temperature that is input into the dialysis machine 22 at inlet port 52 is controlled and maintained at a constant temperature (ideally 28 to 30 degrees C). This decreases the power consumption of the machine 22, since the
20 machine 22 heating load is minimized, as the machine 22 does not have to heat up cold water. Further, the temperature-controlled mixing valve 36 supplies water into the water treatment module 24 close to the temperature at which the reverse osmosis filter 100 (FIG. 5) membrane is most efficient. This maximizes the throughput of water into the machine 22,

- 20 -

thereby reducing water consumption. It should be noted that the temperature-controlled mixing valve 36 could be installed in the inlet circuit of the water treatment module 24 in the event that a water pre-treatment module 20 is not used, for whatever reason, with the benefits still obtained.

5 The pressure regulator 38 further supplies water to the dialysis machine 22 at a substantially constant pressure. A pressure relief valve 78 with integral water sample removal port provides a means for permitting the removal of water from the line 46 downstream of the water treatment unit 40 and to thereby allow for testing of a water sample for the presence of chlorine or chloramines in the water. The sample port allows a fluid
10 sample to be taken from the fluid flow path (i.e., water in line 46) without contaminating the sample. The sample is taken with a syringe or other suitable implement.

 The pressure relief valve 78 with integral sample removal port 138 is shown in a cross-section in FIG. 4A. The valve 78 consists of a standard adjustable pressure relief valve housing having an adjustment member 130 which screws clockwise or
15 counterclockwise relative to housing 133, thereby adjusting the force that the pressure relief spring 144 applies to the plastic plunger 142 and elastomeric diaphragm 140. The elastomeric diaphragm 140 provides a lower boundary to an upper chamber 131. The relief valve housing member 132 has a fluid inlet tube 134 and a fluid outlet tube 136. An integral sample removal port 138 is provided at the base of the housing 132.

20 A cylindrical member 146 is placed within the principal fluid passage chamber 137 with the top rim 139 normally flush against the bottom of the diaphragm 140, thereby preventing entry of fluid over the rim and into the cylindrical member 146 and out the sample removal port 138 under normal pressure conditions in the unit 78. Preferably, the

- 21 -

cylindrical member is integrally formed with the housing 132 of the pressure relief valve. In the alternative construction of FIG. 4C, the cylindrical member 146 is shown as a separate piece and is threaded onto the base of the housing 132 just above the sample removal port 138.

5 A cylindrical plastic insert 148 with a lower tip 152 and an upper surface 154 is placed within the cylindrical member 146. The insert 148 is shown isolated in perspective view in FIG. 4D. The purpose of the insert 148 is to transmit forces from the tip of a syringe 135 inserted into the sample removal port against the base of the diaphragm 140 to lift the diaphragm above the rim 139 of the cylindrical member 146, thereby allowing fluid
10 to escape over the rim 139 down into the sample removal port 138.

FIG. 4B is a detailed view of the upper portion of the chamber 137 when the insert 148 is pushed by the tip of the syringe 135 into an upper position. Referring to FIGS. 4A and 4B, when the user wishes to remove a sample, the user inserts the tip 150 of a syringe 135 into the sample removal port 138. The tip 150 of the syringe 135 pushes against the
15 bottom tip 152 of the cylindrical insert 148, causing the upper portion 154 to push the diaphragm 140 upwards (FIG. 4B). Fluid in the chamber 137 now flows over the rim 139 into the interior region of the cylindrical member 146 (see arrows) and down into the region 156 surrounding the insert 148 and into the sample removal port 138, from where it is pulled into the syringe 135.

20 Chlorine and chloramines have a high level of toxicity to hemodialysis patients, hence their removal from the water used in the dialysate is imperative. The carbon filter agent 44 of water filtration unit 40 removes such substances from the water line, but in the event that the carbon filter agent 44 has exhausted its capacity to remove chloramines or chlorine, the

- 22 -

user will need to replace the water filtration unit 40. After each use of the machine, the user inserts a syringe into the sample removal port, withdraws a sample of the water, and applies the sample to a chloramines or chlorine reagent test strip to see if a color change in the test strip occurs, indicating that chlorine substances are in the sample. A preferred source for the test strips is Serim Research Corporation, P.O. Box 4002, Elkhart, Indiana 46514-0002.

The presence of chlorine or chloramines in a household water supply is ordinarily attributable to municipal water treatment efforts. If the carbon filter agent 44 of the water pre-treatment unit 40 is working properly, the chloramine level in line 46 is normally zero. However, if the carbon filter 44 is exhausted, the secondary carbon filter 88 in water treatment module 24 (FIG. 5) removes the chloramines from the water, insuring safety of the system. Ideally, the user checks for chloramines daily after each dialysis treatment, thereby insuring that in the case that the primary chloramine filter agent (e.g., filter 44) is exhausted, the backup secondary carbon filter 88 does not also become exhausted.

Thus, the present invention provides a method for treating water used for the preparation of a dialysate solution in a dialysis machine, comprising the steps of passing water through a first filter (e.g., carbon filter 44) having chlorine removal properties and passing filtered water into a line, removing water from the line and periodically sampling the removed water for the presence of chlorine or chloramines, the presence of chlorine or chloramines indicating that the filtration capacity for chlorine of the first filter is substantially exhausted, filtering the water downstream from the sample location in a second filter (e.g., carbon filter 88) also having chlorine removal properties, and replacing the first filter if chlorine or chloramines detected during the sampling step.

In the event that a single water filtration unit 84 (FIGS. 3B and 3C) is used (no

- 23 -

pretreatment, as in the case where the patient is traveling with the machine 22 but not the pretreatment module 20), the filter unit 84 has sufficient capacity to be used as the sole source of water pretreatment for up to two weeks depending on the chlorine content in the incoming water. If the chloramine content of the tap water and the filtration capacity of the carbon filtration agent are known, an estimate of the life expectancy of the filtration unit 84 can be arrived at and the replacement of the unit 84 scheduled accordingly. Further, a sample of reverse-osmosis water may be taken at a sample port in the dialysate preparation module 26 of the machine 22, e.g., at the pressure relief and sample unit 210 (FIG. 6) for determination of chlorine of the water while in the travel mode.

10

II. Water Treatment Module 24

Referring now to FIG. 5, the water treatment module 24 of the dialysis machine 22 will be discussed in detail. The water treatment module 24 includes a water line 70 connected to the water inlet 52 that receives water from the water pretreatment module 20. The flow of water into the water treatment module 24 is controlled by a valve 72 (such as Sirai part no. D111 V14 Z723A), three way valve 83 (such as Sirai part no. 311 V14 Z723A) and check valve CV6.

15

The valve 83 has a normally closed (NC) port in communication with a feed line F that supplies water to the ultrafiltration tank 244 for the purpose of rinsing polyphosphate water conditioning agents, if present, from the feed side of the reverse osmosis membrane 100 prior to heat disinfection. The flushing of all ionic species from the feed loop avoids the buildup of insoluble compounds and prevents fouling of the RO membrane.

20

A thermistor 74 (10K ohm from Thermometrics) and pressure transducer 76

- 24 -

(Microswitch part no. 26PC X-98752-PC) monitor the temperature and pressure of the incoming water in the line 72. A check valve CV1 is placed on return line 73.

A three-way valve 80 (such as Sirai part no. 311 V14 Z723A) is provided connecting drain line 71 and inlet line 70 via return line 73. With port 81 in a closed condition, water is shunted into line 82 where it is passed to a pressure transducer 76 to the secondary water
5 filtration and treatment unit 84.

A preferred embodiment of the secondary water filtration and treatment unit 84 is shown in FIGS. 3B and 3C. The water treatment unit 84 is shown in a perspective view in FIG. 3B, and has a cap C with an inlet and an outlet, shown by the arrows. The cap screws
10 onto a generally cylindrically shaped housing H, which houses carbon and particulate filter elements. The unit 84 is shown in a vertical cross-sectional view in FIG. 3C along the lines 3C-3C of FIG. 3B. The cap C screws onto the housing H with an O-ring seal OR preventing any leakage therebetween. Water from the inlet line 82 is led to circumferential inlet chamber P that surrounds a central filtration unit F having the capacity to act as a
15 particulate filter 42 and a carbon filter 44 placed in a second concentric vertically disposed chamber 88. In a presently preferred embodiment, the entire cartridge F is a "briquette" type cartridge made of a resin and ultrafine activated carbon. This solid block of carbon-resin also serves as a 0.5 micron particulate filter. A suitable "briquette" type filter is the CBC-Style Cartridge from Ametek. The inner surface of the chamber 88 is lined with lining
20 L having holes LH permitting filtered water to enter the central discharge chamber D. The central discharge chamber D is in fluid communication with the outlet and passes water into the outlet line 90. The central filtration unit F is retained securely in the housing H by washer seals W at the top and bottom. The housing H is preferably made out of a high

- 25 -

temperature resistant material, such as RYTON™ high temperature plastic. When it is time to replace the filter elements of the unit 84, the user unscrews the cap C from the housing, and lifts the filter unit F out of the housing H and replaces it with a new one. Connectors A and B allow for quick changeout of unit 84.

5 After treatment by the filter 84, the treated water is then fed on output line 90 to water pressure sensor 92 (same as 76) and to an invasive conductivity cell 94 (such as the Pulsa Feeder part no. E-2A). The conductivity cell 94 measures the ion content of water in the line 90. Periodically the pressure sensors 76 and 92 are compared to determine when filter unit 84 is ready for replacement due to a blocked particulate filter 42.

10 In an alternative embodiment where a polyphosphate water conditioning agent is present in the filter 84, a three way bypass valve and bypass line between line 82 and line 90 is provided on line 82 at the inlet to the filter 84 such that, during the disinfection cycle of the machine, hot water bypasses the water filtration and treatment unit 84 to prevent hot water from adversely impacting the integrity of the polyphosphate water conditioning agent
15 in the treatment unit 84. Polyphosphate water conditioning agents are known to degrade when subjected to water at high temperatures for an extended period of time. The normally closed port NC and normally open port NO of the valve allows incoming water from the water pretreatment module 20 to pass through the water filtration and treatment unit 84, but
20 when the condition of these ports is reversed, water is shunted through a bypass line around the filter 84 to the output line 90.

Still referring to FIG. 5, a pump 96 (such as Procon part no. CO16505AFV and Bodine motor) is located in the line 90 to pump the water past a pressure sensor 98 to a reverse osmosis filter 100 (Dow FilmTek XUS 50454.00 filter). A flow restrictor 95 is

- 26 -

placed across the pump 96 to avoid deadhead failure conditions. A valve 112, flow constrictor FC2 and check valve CV4 are placed in return line 110. An adjustable pressure regulator 114 is placed in parallel with the high pressure valve 112 (Sirai, same as above). The pressure regulator 114 provides back pressure for the reverse osmosis filter 100 to force water to cross the membrane. High pressure valve 112 bypasses flow to regulator 114 minimizing back pressure in certain operating modes and failure conditions. Flow constrictor FC2 provides about 10 psi back pressure to RO filter 100 during the hot water disinfection, described in detail below. Lines 110 and 116 are drain lines which drain water rejected by the reverse osmosis filter 100 through valve 80 to drain line 71.

Water that passes through the reverse osmosis RO filter 100 is passed through a line 102, past a thermistor 104, past a conductivity cell 106 (same as 94), to a three way valve 108 having a normally open port NO connected via check valve CV14 to drain lines 109 and 116. When the normally closed port NC of valve 108 is open, reverse osmosis water is fed via line 111 to the dialysate preparation module 26 (FIG. 1, 6). This occurs when a comparison of conductivity cells 94 and 106 verifies proper function of reverse osmosis filter 100. If the comparison yields improper function of reverse osmosis filter 100, the water is diverted to drain through the normally open port of valve 108, and lines 109, 116 and 71.

Line 107 and check valve CV5 provide a pathway for the flow of drain fluids and heated water from the dialysate preparation module 26 to the water treatment module 24. Depending on the condition of three-way valve 80, fluids from line 107 are directed through line 71, or line 73. It will be further appreciated that the valve network in water treatment module 24 permits the selective flow of water through every fluid pathway in the module 24, including (if desired in an alternative embodiment) a bypass of the water filtration and

- 27 -

treatment unit 84. Check valve CV5 further prevents water from being passing through the line 107 when rejected water from reverse osmosis filter 110 is returned to drain line 71.

III. Dialysate Preparation (or Hydraulic) Module 26

5 Referring now to FIG. 6, the dialysate preparation module 26 will be discussed in detail. An overall function of the dialysate preparation module 26 is to automatically mix and prepare the dialysate solutions and deliver the solutions to the dialyzer 404. The dialysate preparation module 26 has an inlet line 200 connected to line 111 (FIG. 5) receiving filtered water from the water treatment module 24 via valve 108 (FIG. 5). The
10 line 200 carries the water past check valve CV10 to a chemical mixing tank 202, preferably constructed from polypropylene. A chemical addition and dispersion subsystem 204 is attached to the side of the tank 202 in fluid communication therewith. The loading platform 250 of chemical addition subsystem 204 is illustrated in FIGS. 7A-7F. The chemical applicator 260 of the chemical addition subsystem 204 is illustrated in FIGS. 8A-8C and 9A-
15 9C. The chemical vessels (ideally bottles) 270 are illustrated in FIGS. 10A-10F.

The addition and dispersion subsystem 204 preferably includes two chemical applicators 260, each for opening a vessel 270 containing an individual batch quantity of dialysis chemicals placed directly above it. One vessel 270 typically contains chemicals in liquid form and the other in powdered form. The batch of chemicals are provided in
20 individual batch vessels, preferably polyethylene and/or polypropylene bottles 270. When the tank 202 is filled with purified water to the proper level, the chemical applicators 260 pierce the bottles 270 from below with a spike, and the chemicals in the bottles fall out of the bottle by gravity and rinsing into the interior of the loading platform 250. As explained

- 28 -

in detail below, a sprayer 285 rinses the chemicals from the loading platform 250 into the tank 202 where the chemicals are dissolved and mixed with water to form the dialysate solution. Additionally, bottle rinsing nozzles are preferably provided within the chemical applicators 260. The nozzles that are disposed below bottles containing dry dialysate chemicals eject water into the bottles in a series of short bursts to gradually flush the chemicals out of the bottles. After the chemicals are dispensed on the loading platform 250, the nozzles flush any remaining chemicals in the bottles 270 from the bottles onto the loading platform 250. A third chemical applicator 260 and third vessel 270 are also preferably provided above the platform 250. The chemicals in the third vessel will typically either be a salt which can be added to the dialysate solution on demand to adjust the chemistry of the dialysate solution, or else a chemical cleaning or disinfecting agent that is added to the tank during the disinfection cycle. Other possible chemicals for the third bottle 270 are medications, and vitamins and other nutritional supplements. As described below, we prefer to use a hot pure water disinfection process, without chemicals, to clean the fluid circuits of the machine 22. However, if for some reason the hot water disinfection is not sufficient, an alternative mode may be entered whereby the disinfecting chemicals in the third vessel are added to the tank and circulated throughout the machine to achieve cleaning and/or disinfection. Of course, additional chemical applicators and vessels could be added to the top of the loading platform 250, if desired.

The tank inlet tube 203 is placed at the bottom of the tank 202 and oriented tangentially to the walls of the tank 202 in a horizontal plane such that the incoming water is swirled about the side of the tank in the direction of the orientation of the inlet 203 to create a vortex, thereby stirring the water in the tank 202. A spray washer 205 similar to

- 29 -

a dishwasher sprayer is provided in the upper region of the tank 202, and is operative during cleaning of the tank 202 and mixing of the dialysate chemicals the tank 202. The force of the water through spray washer 205 causes the spray washer 205 to rotate and spray water into the tank 202 in the same direction as the flow of water in the vortex created by water inlet 203. The cooperation of the spray washer 205 and water inlet 203 create good mixing action in the tank 202, promoting effective dispersion and dissolution of the chemicals introduced into the tank 202 from the loading platform 250, and preventing the settlement of chemicals on the bottom of the tank.

The tank 202 itself is preferably made from a lightweight, biocompatible, chemically compatible, and sterilizeable and substantially non-compliant (i.e., rigid and not susceptible to expansion or contraction due to pressure, temperature or other condition) material, that is given the shape shown in FIG. 6. Other shapes are of course possible. A tank made from polypropylene with the shell reinforced with fiberglass windings on the outside of the shell meets these requirements. The polypropylene is chosen because of its chemical inertness, light weight and ability to be exposed to hot water for long periods without any effect. An alternative material for the shell is polyvinylidene fluoride (PVDF). The reinforcing fiberglass threads significantly improve the non-compliance (or stiffness) of the tank 202. As discussed in detail below, non-compliance of the tank is important for improving the real-time measurement of fluid removed from the patient during dialysis. The fiberglass threads are wound around the exterior of the walls of the tank 202 in overlapping diagonal layers, with an additional layer wrapping about the mid-section of the tank 202 in a horizontal manner. A suitable tank can be obtained from Structural North America in Ohio. Other possible reinforcing fibers may be suitable, such as composite fibers, carbon fibers and

- 30 -

kevlar, which may be integrated into the shell body itself or wound on the outside of the shell. Heating elements may be built into or wrapped around the upper portion of the tank shell to assist in the dialysate separation technique discussed below.

A pressure transducer LT (Microswitch part no. 26PC X-98493-PC) is provided at
5 the bottom of the tank 202 in line 206 for the purpose of determining the level of water in the tank 202. Line 206 is isolated (static, with no fluid flowing through the line) when the NO port of valve V17 for line 206 is closed and the NC port in line 209 is open, permitting the level transducer to read the level in the tank 202. This would be the case when the tank 202 is being filled. During the filling and mixing of the tank, water is circulated from the
10 line 209 to V17 to V9 through pump 212, valves 220 and 232, line 231 to valve V15, and sprayer 205 in the tank 202, which assists in the mixing of the tank 202.

The tank 202 has a mesh filter FTB (130 micron) molded into a flat plate with a polypropylene frame at the bottom of the tank 202. A pump filter FP2 (preferably 50 to 200 microns) is placed on the degassing line 209. Any air or gas which may have been
15 introduced into the dialysate is removed by pumping the dialysate through the filter FP2. The filter FP2 creates a negative pressure which causes entrapped air to come out of the water.

The tank outlet line 206 carries dialysate solution to a pump 212. When the chemicals are released from the chemical addition subsystem 204 to the tank and are being
20 mixed in the tank 202, the circulation of fluid is through line 206 (with degassing line 209 static).

A three-way valve V17 is placed at the intersection of lines 206 and 209 and determines which line 206, 209 is static. The pump 212 (such as Micropump EG series, 0-3

- 31 -

L/min.) pumps the solution past a pressure transducer 214 (Microswitch PN 26PC X-98752-PC),

Referring again to FIG. 6, a three-way valve 220 controls the flow of fluid through output line 226 and return line 236. Water or solution in line 226 is fed to a heater assembly 228. Heater assembly 228 is a temperature controlled, 1300 watt, flow-through heater, such as the Heatron no. 23925 heater. The heater assembly 228 is used for heating dialysate up to body temperature as it is passed to the extracorporeal circuit module 28 (FIG. 1). The heater is also used for heating water up to a disinfection temperature of at least 80 degrees C., and preferably at least 85 degrees C., and maintaining the water at that temperature for more than an hour during the water disinfection of the fluid paths of the machine 22, as discussed in detail below.

After passing through the heater 228, the water passes through a flow meter 241 (such as the Digiflow™ unit) which measures the flow rate of the solutions in line, and a safety thermistor THS. A second thermistor 230 is used to control the temperature of the fluids in the line 226. A three-way valve 232 controls the flow of fluid through the tank return line 231 and the output line 233. A dialysate filter such as ultrafilter/pyrogen removal filter 234 is provided for removal of any pyrogenic materials and particulate matter from the dialysate. A preferred filter 234 is the Minntech Renaguard™ pyrogen filter. No dialysate solution goes to the dialysate circuit 402 during dialysis treatment without first passing through the filter 234. The condition of three-way valve 236 controls whether fluid exits from the ultrafilter/pyrogen filter 234 through line 238 or out dialysate circuit input line 406.

A check valve CV12 is placed between line 238 and 206. Line 238, check valve CV 13 and valve V22 allow air to come out of the ultrafilter 234 (i.e., the outside of the fibers

- 32 -

in the filter 234) during the priming of the ultrafilter 234 and pumping of dialysate through the ultrafilter 234 to the dialysate circuit 402.

We have devised a pre-treatment fiber bundle integrity test for the pyrogen/ultrafilter 234. The integrity of the ultrafilter 234 is important to insure that there are no leaks. The pyrogen/ultrafilter is pressurized on the "blood" side (that is, the interior of the fiber bundles in direct fluid communication with the dialyzer 404) of the ultrafilter 234 prior to dialysis, and the rate of pressure decay is measured. A rapid pressure decay, or inability to pressurize the pyrogen/ultrafilter, will cause an alarm to sound, warning the patient of the need to replace the pyrogen/ultrafilter 234. To accomplish this, we first evacuate fluids from the blood side of the pyrogen/ultrafilter 234 by operating the UF pump 242 in the reverse direction to pump air back through the valve 236, through bypass valve 412 in the dialysate circuit 402, through line 406 into the lumen or blood side of the pyrogen/ultrafilter 234. Once water has been evacuated from the blood side of the pyrogen/ultrafilter 234, the blood side starts to pressurize (assuming there are no leaks in the pyrogen/ultrafilter 234). The UF pump 242 pumps until the pyrogen/ultrafilter 234 is pressurized to 500 mm Hg. If there are any leaks, air will leak into the dialysate side of the filter 234. The air pressure is measured with the pressure sensor 410 in the dialysate circuit 402. If pressure sensor 410 never pressurizes, then a severe leak is present. A slow decay in pressure indicates there is no leak. The rate of decay indicative of a leak requiring replacement of the pyrogen/ultrafilter is a function of the physical properties of the filter's membrane, and will accordingly vary depending upon which filter is used. For most filters 234, we expect the threshold decay rate indicative of a failure to be greater than 10-25 mm Hg/30 seconds, depending on the type of filter.

- 33 -

The pressurization of the pyrogen/ultrafilter 234 can also be correlated to the maximum pore size of the filter. As the pyrogen/ultrafilter 234 is pressurized to higher and higher pressures, a maximum pressure will be reached above which the pressure drops suddenly indicating that the surface energy of water in the pores of the filter is less than the force due to the pressure. By knowing the pore size from the maximum pressure, the filtration capacity for certain pyrogens and other materials may be determined.

Referring to FIG. 16, it will be appreciated that the analog board 614 and central processing unit 610 of the central control module receive the pressure data from the pressure sensor 410. Pressure readings indicative of a leak, such as where the rate of decay is greater than a predetermined threshold limit, will cause the CPU 610 (or safety CPU 616) to issue an alarm, such as by issuing a message on the patient interface, or activating the audio or visual indicators 604 or a buzzer.

During the filling of the tank 202, after the chemicals are added, the machine 22 determines when to stop adding water to the tank by monitoring the fluid sensor 288 in the line coming out of the top of the tank 202. When fluid sensor 288 sees fluid, the flow of water is stopped by closing off valve 108 (FIG. 5).

The return flow of old solution (i.e., solution that has passed through the dialyzer) from the dialyzer 404 is through return line 240, valve V18 and dialysate inlet 243. Valves V19, V15 and V6 are closed, directing dialysate through to the dialysate inlet 243. An integral pressure relief valve with sample removal port 210 is placed in the line at the top of the tank 202 leading to valve V6.

We have invented a technique of maintaining the separation of new and old dialysate in the tank 202 by taking advantage of the differences in density in dialysate when the

- 34 -

dialysate is at different temperatures. Our technique is an improvement over the technique described in the Terstegen Patent, U.S. No. 4,610,782. The preparation and mixing of dialysate in the tank 202 takes place with the dialysate at a temperature of 28 to 30 degrees C. This temperature is controlled, in the preferred embodiment, by the temperature-
5 controlled mixing valve 38 in the water pretreatment module 20. During dialysis, dialysate is heated in the heater 228 to body temperature, generally 37 degrees C, and sent to the dialyzer 404 in the extracorporeal circuit module 28 (FIG. 13). New (i.e., fresh) dialysate is withdrawn from the bottom of the tank 202 and old dialysate is returned at the top of the tank 202 in inlet 243 at a temperature of about 37 degrees C, or perhaps a degree or two
10 cooler due to radiative and conductive heat loss in the tubing and hardware in the dialysate circuit 402.

The old dialysate is returned to the top of the tank 202 in a manner so as to substantially prevent turbulence of the "old" or returned dialysate, that is, in a manner to gently introduce the returned dialysate into the top of the tank to prevent mixing of the
15 returned and fresh dialysate. A preferred method of accomplishing this is to provide a circular inlet tube at the center of the top of the tank 202 with a series of small holes in the tube pointed radially inward. As the returned dialysate enters the inlet tube, it gently passes through the holes into roughly the center of the top of the tank. An alternative embodiment accomplishes the introduction of returned dialysate with minimal turbulence by orienting an
20 inlet 243 slightly upward and towards the side walls of the tank 202. The returned dialysate forms a zone above the fresh dialysate with a thermocline boundary layer separating the returned and fresh dialysate due to the temperature differential (and resulting density differential) between the dialysate in the two zones. As the dialysis process continues, the

- 35 -

boundary zone migrates down the tank 202 as the volume of fluid in the upper zone of returned dialysate increases and the volume of fresh dialysate diminishes. This method works best when the temperature differential between the upper zone and lower zone is at least 5-7 degrees C, or greater, but will work acceptably down to 3 degrees C. Ordinarily, this differential will be present when the dialysate is heated as described.

An improvement to this technique is to heat one to two liters of new dialysate above the temperature of the dialysate in the tank 202 (by preferably at least 5 degrees C) prior to the initiation of dialysis, and introducing the heated dialysate into the top of the tank in a substantially non-turbulent manner. This sets up the temperature differential zones such that when the old (used) dialysate is introduced into the tank, it enters the upper zone, further minimizing the likelihood of substantial mixing of the old and new dialysate. The heating can be performed by heater 228, and the return of the heated dialysate is through valve 232, return line 231 and valve V18. Valves V6, V15 and the NO ports of valves 236 and 232 should be closed to direct the heated dialysate into the tank 202.

The separation of returned and fresh dialysate in the tank 202 offers a number of advantages. First, it allows a closed loop ultrafiltration control methodology to be used. Second, the fluids being dialyzed from the patients are collected in the tank 202 separate from other solutions, permitting the old dialysate to be sampled, measured, and visually observed in a tank with a window or a sample-removal port. Thirdly, the closed loop ultrafiltration permits the machine to operate, during dialysis, without the machine being connected to a water source and a drain. This gives more mobility to both the machine 22 and the patient, a feature particularly advantageous in the hospital, home and nursing home environments. Fourthly, separation of old and new dialysate improves the efficiency of

- 36 -

clearance of uremic toxins for a batch system.

A UF (ultrafiltration) pump 242, connected to the return line 240 through valve 236, pumps dialysate solution to and from the UF tank 244, the direction of flow being a function of whether the UF pump 242 is operated in a forward or reverse direction. NC port of valve
5 V9 is closed and NO port of valve V13 is open providing the pathway for the solution to enter the bottom of the tank 244. The UF pump 242 is also used to pump priming solution from the extracorporeal circuit 400 back to the UF tank 244.

The UF tank level sensor PUH precisely measures the fluid volume in the UF tank 244. The UF tank 244 is used to store fluid removed from the dialysate circuit commensurate
10 with the fluid removed from the patient. The fluid removed from the patient is the difference in the volume of fluid in the UF tank before and after the dialysis procedure. The rate of fluid removal into the UF tank 244 (and hence total volume when multiplied by time) is controlled by the pump rate of UF pump 242. A sterile barrier air filter AF (such as Pall
EMFLON II) open to the atmosphere is installed at the top of the tank 244. Background
15 information on ultrafiltration control in hemodialysis is described in U.S. Pat. Nos. 3,974,284 and 3,939,069 assigned to Rhone-Poulenc (both now expired), which are incorporated by reference herein.

The pressure transducer PUH is mounted at the bottom of the UF tank 244. The transducer PUH measures the pressure and hence level of fluid in the tank 244. The level
20 sensor PUS acts as a safety backup and watchdog for the UF pump 242 to verify the amount of ultrafiltration during dialysis. Specifically, the sensor PUH measures the hydrodynamic pressure of dialysate in the ultrafiltration tank 244 and responsively generates a measurement signal (sent to the control module 25) indicative of the volume of fluid within the UF tank

- 37 -

244. Alternatively, the rate of transport of fluid by UF pump into the UF tank 244 is continuously monitored. A further alternative is knowing the output volume per revolution of the UF pump, and the time elapsed during dialysis. This information allows the central control module 25 (FIG. 16) to determine the expected volume of dialysate in the UF tank

5 244. By comparing the measurement signal from the sensor PUH with the expected volume of dialysate in the UF tank, the pump rate of pump 242 is verified.

In one possible implementation of this technique, a decision as to the adjustment of the dialysate transport rate into the UF tank (i.e., the pump 242's pump rate) can be made. For example, if sensor PUH indicates that there is 350 ml of fluid in the tank 244 but a

10 calculation of the expected volume of fluid in the UF tank based on pump rate and elapsed time is 385 ml, the pump 242 is pumping about 10 % too slow and the pump speed should be increased to meet the ultrafiltration target in the expected dialysis time.

After the tank 202 and fluid circuits of the dialysate preparation module 26 have been filled with dialysate, positive pressure is created with pump 212 in line 209. Dialysate is

15 conducted from tank 202 through valve V9, through UF pump 242, to valve 236, down through CV12, line 206, valve 220, valve V8 and into pyrogen/ultrafilter 234. The dialysate is sent up through flow meter 241 to the dialysate circuit 402, where the solution goes through bypass valve 412, through return line 422, line 240, valve V18 and back to the tank

20 202. During dialysis, dialysate is pumped from the dialysate circuit into the ultrafiltration tank 244 via line 240, valve 236 and valve V13 in accordance with the target ultrafiltration volume for the patient.

Air and drain paths 282 and 280 are provided in the module 26 for collecting any fluid or condensate from the tank 202. An optical fluid sensor 288 is used to detect when

- 38 -

the tank 202 is full during the tank fill mode, to detect failure of valve V6 during dialysis, and detecting water or dialysate in the hose portion (solid line) from valve V6 to air filter AF.

5 In our design, the housing of the dialysate preparation module 26 includes a floor or base for the entire machine 22, including the other modules 24 and 28. Any fluid such as blood, water or dialysate that leaks from the modules 24, 26 or 28 collects in a catchment basin 284 at the bottom of the entire machine. Leaks will drip on any arbitrary path, shown schematically as broken lines 280 and 282. The floor of the housing for the machine 22 is horizontally non-planar to facilitate the catchment of fluid, in a fashion similar to an oil pan
10 for an engine. The floor of the machine may be bowl shaped or given any other suitable contour to provide a lower catchment basin 284. A fluid sensor 286 is placed in the vicinity of the catchment basin 284 to detect the presence of fluid in the catchment basin 284. If fluid is detected, the user is alerted by an audio or visual indicator, and the machine is checked for leaks.

15 Referring now to the left-hand side of FIG. 6, a line 283 is provided for conducting water to the chemical application system 260 for rinsing the dialysate chemical bottles 270 after they have been opened, and for disinfection of the bottle's seal. Line 281 is a return line from the chemical application system 260 to valve V13. Line 291 also provides water from three-way valve 287 to a fountain or sprayer 285 in the chemical loading platform 250.
20 Drain lines 236A and 236B provide a pathway for dialysate or disinfection water to exit from the extracorporeal circuit module 28 via the disinfection manifold 494 (see FIG. 28 also) through valve V14, and thermistor 293. A pressure relief/sample port 215 is placed in a drain line 236C connected to the valve 220. The pressure relief/sample port 215 is a

- 39 -

combination pressure relieve valve and integral sample removal port of the same design as pressure relief/sample port 78 (see FIG. 4), and is used to take fluid samples from the system.

5 Lines 289 and 289A provide a fluid pathway into the extracorporeal circuit module 28 via valve CV11. Line 295 connects the disinfection port 495 of the disinfection manifold 494 (FIG. 28) via line 496 and valve V24 (FIG. 13). Thermistor 293 monitors the temperature of the fluid returning from the extracorporeal circuit 400 during the hot water disinfection cycle.

10 **A. The Chemical Loading Platform 250**

The chemical loading platform 250 of FIG. 6 is illustrated in detail in FIGS. 7A-7F. FIG. 7A is a perspective view of the platform 250 shown positioned against the side of the tank 202. FIG. 7B is a top plan view of the platform 250. FIG. 7C is a sectional view of the platform 250 along the lines 7C of FIG. 7B. FIG. 7D is a sectional view of the platform 250 along lines 7D of FIG. 7B. FIG. 7E is an elevational view of the platform 15 250. FIG. 7F is a sectional view of the platform 250 along the line 7F of FIG. 7E. In the figures, the platform 250 is an integrally molded housing mounted to the side of the tank 202 and having a top 304 with four apertures. Apertures 306, 308 and 310 provide passageways for chemicals from the chemical application assemblies 260 which are installed above the top 20 304 of the platform 350. Aperture 312 is for a line 291 (FIG. 6) to provide water to a sprayer 285 suspended within the platform 250 for rinsing chemicals from the shelf 320 into the tank 202. (See FIG. 6). Shelf 320 is inclined at an angle of between 10 and 30 degrees (preferably 17 degrees) relative to the horizontal to promote dispersion of chemicals

- 40 -

delivered onto shelf 320 into the tank 202. Note that the tank 202 has fiberglass windings 314 wrapped around a polypropylene shell 316.

The platform further has a rim 302, 326 and sidewalls 318 and 319. The chemicals are placed in fluid communication with the interior of the tank by virtue of the open side 324 of the platform 250, which is aligned with an opening (not shown) in the tank 202.

Referring to FIG 6. and 7D, the sprayer 285 sprays fluid (e.g. dialysate or purified water) in the direction of the lower shelf 320 to assist in washing dialysate chemicals off the shelf 320 and into the tank 202, thereby promoting effective dissolution of the chemicals within the tank 202 and the avoidance of buildup of chemicals on the shelf 320.

Referring in particular to FIGS. 7C and 7D, an aluminum plate 322 is mounted to the top of the platform 250 to provide a mounting base for the chemical application assemblies 260 (FIGS. 6, 8A-8C).

B. The Chemical Applicator 260

Referring now to FIGS. 8A-8C, the chemical applicator 260 will be explained in detail. The chemical applicators 260 (three in all in the preferred embodiment) are installed on the aluminum plate 322 directly above the apertures 306, 308, 310 (FIG. 7A). FIG. 8A is an elevational view of the applicator 260, and FIGS. 8B and 8C are sectional views of the applicator 260 with the spike 330 in upper and lower positions, respectively. When the spike 330 is in the upper position (FIGS. 8A and 8B), the tip 331 of the spike pierces the bottle 270 which is installed in an upside-down orientation in the upper region 332 of the applicator 260, causing the chemicals in the bottle 270 to pour out through the applicator 260 and apertures 306 (or 308 or 310) and onto the shelf 320 of the loading platform 250 (FIG. 7).

- 41 -

The applicator 260 has a cylindrical housing 334 mounted to a base member 336 affixed to the aluminum plate 322. The housing 334 has an open interior region 338. A threaded drive collar 340 is mounted to the housing 334. The spike 330 is reciprocable within the interior region 338 between upper and lower positions. The spike 330 pierces the seal on the bottle 270 or other vessel containing the dialysate chemicals (or other contents of the bottle 260) when the spike 330 is moved to the upper position (FIG. 8B). The spike 330 has an integral cylindrical body 342 concentric with the housing 334 with an open interior for permitting passage of dialysate chemicals therethrough after the spike 330 has pierced the seal of the bottle 270. A pair of thread blocks 344 are mounted to the side walls of the spike 330 which engage the threads 346 on the drive collar 340. A drive belt 348 (one or two) or other suitable means (such as a cog or pinion) engages the threaded drive collar 340 (FIG. 8A). As the belt 348 rotates the collar 340, the thread blocks 344 are rotated, causing the spike 330 to move between the upper and lower positions depending on the direction of movement of the drive belt 348.

Referring in particular to FIGS. 8B and 8C and FIG. 12, a nozzle 350 is disposed within the cylindrical housing 334 in communication via line 281 with the water inlet line 200. The cylindrical body 342 of the spike has a vertical slit to accommodate the nozzle 350. The tip 352 of the nozzle 350 is oriented upward in the direction of the bottle 270 when the bottle 270 is mounted to the housing 332. The flow of water through the nozzle 250 on demand ejects water towards the interior of the bottle 270 after the bottle has been opened by the spike 330, thereby rinsing the interior of the bottle 270 and promoting the release by gravity of the entire contents of bottle 270 through the aperture 306 (or 308, 310) and into the tank 202. To control the dispensing of dry dialysate chemicals from the bottle, and

- 42 -

prevent clogging of chemicals at the base of the bottle, we prefer to pulse water through the nozzle 350 over a period of time. For example, we pulse water through the nozzle for one second (with a pressure greater than 10 psi), then pause briefly while some of the chemicals fall through the interior of the spike 330, then pulse again, pause, and then continue the process until all the chemicals have fallen out of the bottle. This pulsing may occur for perhaps 50 times over a ten minute period. This pulsing action prevents all of the chemicals from being dumped at once onto the shelf of the loading platform. When the bottle is substantially empty, the nozzle rinses out the bottle with a continuous stream of water of 5 to 10 seconds duration.

The nozzle 350 also ejects heated water (or water treated with disinfecting chemicals) onto the outside surface of the seal 372 of the bottle 270 during the disinfection cycle of the machine, thereby disinfecting the interface between the chemicals in the bottle 270 with the dialysate preparation tank 202.

An O-ring 329 is provided around the base 335 of the spike 330. When the spike is in the lower position, outlet tube 337 leading to line 281 (FIG. 6) is open and the tank 202 is closed off through ports 306, 308 and 310.

C. The Chemical Vessel (Bottle) 270 and Automatic Identification System

Referring now in particular to FIGS. 8C and 9A-9C. together with FIG. 10A, a bottle mounting member 354 is placed above the housing 334 of the applicator 260 to insure that the bottle 270 is mounted in alignment with the spike 330 to the applicator 260. The mounting member 354 is shown in a top plan view in FIG. 9A (i.e., as it would be seen when looking down from above in the direction of the top of the spike), in a bottom plan

- 43 -

view in FIG. 9B, and in side elevational view in FIG. 9C. The mounting member 354 has a central opening 360 through which the head of the bottle 270 is inserted. A button through hole notch 356 accommodates a touch button 362 (FIG. 10A) containing coded information as to the contents of the bottle 270 that is affixed to the neck of the bottle 270. The touch button 272 is about a half inch in diameter. The member 354 has a pawl 357 (that is retractable by operation of an electric solenoid 358) for automatically removing the touch button 362 when the bottle 270 is removed from the mounting member 354.

During installation of the bottle 270, the head of the bottle 270 (turned "upside down") is placed within the opening 360 and rotated in the direction of the arrow of FIGS. 9A and 9C. The touch button 362 slides past the pawl 357 into contact with a touch button reader. When the bottle 270 is removed from the applicator, the bottle must be rotated in the opposite direction. Pawl 357 is activated by solenoid 358 to an extended position. When the bottle is rotated such that the touch button is rotated past the pawl 357, the pawl 357 pushes the touch button 362 off of the bottle 270, causing the touch button to fall. A suitable catchment structure is provided about the applicators 260 and aluminum shelf 322 (FIG.8) to catch and collect the fallen touch buttons. The user of the machine 22 collects the buttons and sends them back to a collection center for reprogramming and reuse. Alternatively, the buttons 362 could be collected by a service technician during a service visit.

The structure of the bottle 270 is shown in detail in FIGS. 10A-10F. FIG. 10A is an elevational view of the bottle 270 with the touch button 362 removably affixed to the neck region 364 of the bottle 270. FIG. 10B is a sectional view of the neck region 364 of the bottle 270 showing the polyethylene or polypropylene shell 380 and a polypropylene cap 370

- 44 -

that is attached in any convenient fashion to the shell, such as by threaded engagement. An alternative embodiment is one in which the cap 370 is snapped onto the shell 380 via circumferential complementary snap elements. A polypropylene seal 372 integral with the cap 370 closes off the bottle 270. Polypropylene is chosen for the material for the cap 370 since the cap 370 is subject to hot water disinfection during the disinfection cycle of the machine 22. Specifically, when the bottle 270 is installed within the mounting member 354 above the applicator 260, hot water is applied via nozzle 350 (FIG. 8C) to the exterior surface of the polypropylene seal 372. While polyethylene is a preferred material for the bottle shell 380, it tends to soften when subjected to hot water for an extended period of time.

FIG. 10C is a detailed elevational view of the upper portion of the bottle showing the pinch semicircular rim 366 that retains the touch button 362. FIG. 10D is similar to FIG. 10C with the cap 370 rotated 90 degrees. A retaining bead 368 helps keep the touch button 362 in place. FIG. 10E shows the opposite side of the cap 370 from FIG. 10C. The threads 367 engage the upper portion of the housing 334 of the applicator 260 (FIG. 8).

FIG. 10F is a plan view of the seal area 372 of the bottle 270. The seal 372 comprises a frangible section 374 and a hinge section 376. The mounting member 354 (FIG. 9), and in particular the notch 356, acts as a means for insuring that the bottle 270 can be inserted only one way onto the applicator 260 and aligning the upper tip of the spike with the frangible section 374 of the seal opposite the hinge section 376, so that the tip 331 of the spike 330 (FIG. 8B) contacts the region 384 of the seal 372. The uppermost rim of the spike 330 tears through the frangible section 374, with only the hinge portion 376 uncut, when the spike 330 is moved to its upper position (FIG. 8B). By virtue of the stiff properties of the

- 45 -

polypropylene material, and by virtue of the support from the spike 330 from below when the spike 330 is in the upward position, the broken seal 372 maintains an generally upward orientation, allowing the chemicals in the bottle 270 to exit from the bottle 270 and permitting the nozzle 350 to spray into the interior of the bottle 270 to rinse out any
5 remaining chemicals in the bottle 270. The rinsing action of a bottle 270 containing dry dialysate chemicals is shown in FIG 12.

When the bottle 270 is mounted to the applicator 260, the touch button 362 is placed in touching contact with a touch button reader mounted in any suitable fashion above the applicator 260. The reader retrieves information coded in the button 362 (such as the
10 contents of the bottle, a date code, a lot code, and other information) and passes the information to the central processing unit of the control module 25 (FIG. 1). The control module 25 has a memory storing information such as the correct dialysate chemicals for the patient, the patient's dialysis prescription, and software for processing the information from the touch button. If the bottle does not contain the proper chemical for the patient, the
15 control module 25 alerts the user, such as by activating a suitable alarm. The user, thus alerted, removes the incorrect bottle 270 prior to commencement of the next dialysis procedure and replaces the bottle 270 with the proper bottle, and the process goes forward. If a removeable touch button is used for the indicator, it should not be detached when the bottle is removed from the applicator. Touch buttons, readers and supporting materials
20 suitable for use with the present invention can be obtained from the Dallas Semiconductor Corp., 4401 S. Beltwood Parkway, Dallas Texas. The above-described identification technique promotes safety and the prevention of unintentional introduction of the wrong dialysate chemicals into the tank.

- 46 -

It will be appreciated that other types of indicators besides touch buttons may be applied to the bottles such that the indicator is read by a machine when the bottle is about to be used. For example, bar codes, two and three dimensional bar or dot matrices, radio frequency transmitters or magnetic strips may be affixed in any suitable fashion to the sides
5 of the bottles and read by the appropriate machine in a well known manner. Ideally, the reading occurs during or immediately after installation of the bottle and prior to the opening of the bottles and introduction of the chemicals to the tank 202, so that in the case that the wrong bottle was installed, the patient is alerted and corrective action can be taken.

10 **D. The Dialysate Circuit 402**

The dialysate preparation module 26 further includes a dialysate circuit 402 that circulates dialysate from the tank 202 to the dialyzer 404 and back. The dialyzer 404 (such as the Fresenius F-80 filter) filters blood to remove toxins and excessive water buildup in the patient's blood. The patient's blood is introduced into the machine via the extracorporeal
15 circuit 400 (FIG. 13).

The inlet line 406 carries dialysate solution to a thermistor 408, which monitors the temperature of the fluids in the line 406. A pressure transducer 410 (Microswitch 26PC X-98752PC) monitors the pressure in the line 406. Bypass valve 412, and input and output valves 414 and 416 control the flow of dialysate into and out of the dialyzer 404 via input
20 line 418 and output line 420.

During dialysis, the thermistor 408 data is fed to the safety CPU 616 (FIG. 16) to insure that the temperature of the dialysate is less than a maximum critical temperature, in the present example 39 degrees C. If the temperature is greater than the critical temperature,

- 47 -

the safety CPU 616 closes off valves 414 and 416 and opens up bypass valve 412. Conductivity sensor 426 data (FIG. 6) is also fed to the safety CPU 616 and if abnormal conductivity readings are sensed, the valves 414 and 416 are closed and bypass valve 412 is opened.

5 The return flow of old dialysate is via line 422. A noninvasive conductivity monitor 426 and a blood leak detector 428 are provided in the line 422. Blood leak detector 428 detects a leakage of blood from the dialyzer 404 into the dialysate. The presence of blood in the line 422 also causes valves 414 and 416 to close and valve 412 to open, to prevent any additional loss of the patient's blood.

10 The noninvasive conductivity cell 426 is illustrated in detail in FIG. 11A. The inlet line 422 is divided into first and second fluid channels 423 and 427 integral with the inlet line 422. The channels 423 and 427 are constructed such that the flow of fluid is evenly split between the passages to minimize response time. In the embodiment of FIG. 11A, the channels 423 and 427 branch in directions 90 degrees from each other. The purpose of this
15 construction is to insure equal flow paths in the two channels. The channels are each oriented at an angle of approximately 135 degrees relative to the inlet line 422. The channels 423, 427 form a rectangular loop with the inlet line 423 and the outlet line 422' at opposite corners. A conductivity measurement sensor (e.g., Great Lakes no. 697 E sensor) 224 with leads 225 is circumferentially disposed about one of the fluid channels. The leads
20 225 from the sensor 224 are fed to the central processing unit 610 or 616 of the user interface and control module 25 (FIG. 16). An alternative construction is shown in FIG. 11B, where channels 423A and 425A are shorter than channels 427 and 423. With either construction, the conductivity cell 426 is preferably installed in a vertical or vertically

- 48 -

inclined orientation such that fluid flows upwards through the channels 423 and 427 which prevents the entrapment of air bubbles in the fluid line 427.

The construction of FIG. 11B provides a minimum path-length to cross-sectional area ratio for the fluid channels 423 and 427. This construction generally maximizes the sensitivity of the sensor 426 and reduces response time.

An alternative embodiment of the conductivity sensor is shown in FIG. 11C. The inlet 422 is connected to a molded polysulfone Y fitting containing two passageways for the two channels 423 and 427. The channels meet at the opposite Y fitting and go out the outlet 422'. The conductivity sensor 224 is placed around one of the tubes, preferably made from a hard plastic such as KYNAR, between the Y fittings. The Y fittings split the incoming fluid into two substantially equal channels 423 and 427. The entire assembly 426 is preferably mounted in a vertical orientation so as to prevent the entrapment of air bubbles in the line channel 427.

15 E. The Blood Leak Detector 428

Background information on blood leak detectors known in the prior art can be found in U.S. Pat. Nos. 4,925,299; 4,166,961; 4,087,195, 4,087,185 and 4,017,190, the contents of which are incorporated by reference herein. Our presently preferred design, based on absorbency of light by the blood, is shown in schematic form in FIG 25A. A light emitting diode (LED) 530 is pulsed between an OFF condition and an ON condition, during which it emits light at which the absorbency of the light by blood is at a maximum, such as 880 nm. The light from the diode 530 passes through a mirror-coated beam splitter 532. The resulting light of intensity P is split into two portions. One portion is directed toward a

- 49 -

reference photodiode 534, and the other portion is directed through a chamber or cuvette 536 containing dialysate solution and onto a second blood detector photodiode 538 identical to the reference photodiode detector 534. The reference photodiode 534 also receives light from external interfering light sources P_{EXT2} directed onto the diode 534. The reference diode 534 is used for generating a light intensity correction factor, as discussed below. Photodiode 534 is connected to an operational amplifier 540 having a resistor 542. The output voltage of the op. amp. 540 is represented by V_{PD2} .

External interfering light sources P_{EXT1} also impinge on the photodiode detector 538. The photodiode detector 538 is connected to operational amplifier 546 having resistor 533 connected across the output and negative terminals as shown. The resulting output voltage signal is represented by V_{PD1} . Suitable beam splitter and optical diffusing glass components for the detector of FIG. 25A can be obtained from Edmund Scientific Co., of Barrington, New Jersey.

The housing for the blood leak detector (not shown) is constructed so as to deflect any air within the cuvette 536 away from the light path 535. Curved entry paths or baffle plates may be used for this purpose. The goal is to prevent air bubbles for adhering to the transmitting and receiving windows 537 and 529, respectively on the sides of the cuvette 536. Maintenance of turbulence of the fluid within the cuvette 536 should accomplish this, but the above-cited blood leak detector patents disclose additional techniques for the avoidance of air-bubbles along the light path of a sensor.

The signal flow of the blood leak detector 428 of FIG. 25A is shown in FIG. 25B. The following is a table of the legends used in FIG. 25B.

P = LED 530 Light Intensity

- 50 -

K_C = Light Attenuation of Cuvette 536 and Dialysate

K_S = Attenuation Coefficient Due to Blood in Dialysate

P_{EXT1}, P_{EXT2} = External Interfering Light Sources

K_{PD1}, K_{PD2} = Photodiode 538, 534 Sensitivity Coefficients, respectively

5 V_{OFF1}, V_{OFF2} = Electronics Offset Coefficients for 546, 540, respectively; and

$V_{PD1} = (P \cdot K_C \cdot K_S + P_{EXT1}) K_{KD1} + V_{OFF1}$

Prior to dialysis, a control solution consisting of dialysate solution free from blood in introduced into the cuvette 536, the light source 530 is pulsed on and off and measurements of the light intensity in the reference and blood leakage photodetectors 534, 538 respectively are made. The measurements during the light off condition are stored and subtracted from the next light-on measurement. The process is repeated during the conduction of dialysate solution from the dialyzer 404 during dialysis. A calculation of an attenuation coefficient indicative of the presence of blood in the dialysate is made repeatedly during dialysis, and an alarm is sounded if blood is detected. The provision of the reference detector 534 permits the removal of any offset or drift conditions in the electronics or variation in the light intensity from the light source 530.

10

15

The photodiodes 534, 538 must be shielded from extraneous light sources such as incandescent bulbs or fluorescent lights. Any residual light appearing on the detectors P_{EXT1} and P_{EXT2} is low-pass filtered. The filtering passes only the DC component of the extraneous signal. The DC component of the extraneous signal is removed in the on-off pulsing that removes electronic offset and drift.

20

Any additional light paths from source to detector must also be minimized. Light paths other than that through the dialysate will cause the measurements to deviate from the

- 51 -

expected levels for a given concentration. This cannot be corrected since the offset measurement is taken with the light source off. The extraneous light path can be measured by a given cuvette by replacing the dialysate with a fluid of virtually no light transmittance. Then the light source is varied from 0 to maximum output and the detector output monitored.

5 The blood concentration measurement is as follows. Prior to treatment, the light intensity at the photodiode detectors 538 and 534 is measured before the dialysis treatment.

(1) No Blood $K_s = 1.0$, Light Off $P=0$

$$V_{PD1OFF}' = P_{EXT1} K_{PD1} + V_{OFF1}$$

10 (2) No Blood $K_s = 1.0$, Light on P

$$V_{PD1ON}' = (PK_C + P_{EXT1}) K_{PD1} + V_{OFF1}$$

If P_{EXT1} , K_{PD1} , V_{off1} Constant Between 1 + 2

$$V_{PD1ON}' - V_{PD1OFF}' = PK_C K_{PD1}$$

15 During treatment, the light intensity at the detector 538 is measured. The ratio of the intensity before treatment over the intensity during treatment is computed. In addition, the reference photodiode detector 534 is measured to correct the intensity readings during treatment from offset, drift, and extraneous light sources. Measurements and calculations are as follows:

20 (3) Blood K_s , Light Off $P = 0$

$$V_{PD1OFF} = P_{EXT} K_{PD1} + V_{OFF1}$$

(4) Blood K_s , Light On P

$$V_{PD1ON} = (PK_C K_s + P_{EXT1}) K_{PD1} + V_{OFF1}$$

- 52 -

If P_{EXT1} , K_{PDI} , V_{OFF1} Constant Between 3 + 4

$$V_{PDI ON} - V_{PDI OFF} = PK_C K_S K_{PDI}$$

The attenuation coefficient due to the presence of blood in the dialysate, K_S , is as follows

5 (assuming K_C , K_{PDI} are constant during the treatment):

$$\frac{V_{PDI ON} - V_{PDI OFF}}{V_{PDI ON}' - V_{PDI OFF}'} = \frac{PK_C K_S K_{PDI}}{PK_C K_{PDI}} = K_S$$

10 Suppose that the light intensity from the LED 530 increased 50% after the initial measurements prior to dialysis were made, for whatever reason. The attenuation coefficient K_S is the same. The manufacturers' variations for light intensity P , photodiode sensitivity K_{PDI} and K_{PD2} will not effect the calculation of the attenuation coefficient, since they cancel out.

15 Thus:

No Blood, Before Treatment

$$V_{PDI ON}' - V_{PDI OFF}' = PK_C K_{PDI}$$

Blood, During Treatment

$$V_{PDI ON} - V_{PDI OFF} = P(1.5) K_C K_S K_{PDI}$$

20 The reference detector 534 is used for correction:

No Blood, Before Treatment

$$V_{PD2 ON}' - V_{PD2 OFF}' = P K_{PD2}$$

Blood, During Treatment

$$V_{PD2 ON} - V_{PD2 OFF} = P(1.5) K_{PD2}$$

- 53 -

o Attenuation Calculation (If K_C , K_{PD1} , K_{PD2} , Constant During Treatment)

$$5 \quad \frac{V_{PD1ON} - V_{PD1OFF}}{V_{PD1ON}' - V_{PD1OFF}'} \times \frac{V_{PD2ON}' - V_{PD2OFF}'}{V_{PD2ON} - V_{PD2OFF}} = \frac{P(1.5) K_C K_S K_{PD1}}{P K_C K_{PD1}} \times \frac{P K_{PD2}}{P(1.5) K_{PD2}} = K_S$$

10

It will additionally be noted that the above calculations of K_S assume the beam splitter 532 is a 50% splitter directing light in two paths of equal intensity P. A different ratio of the light intensity could be used with a conversion factor used in the K_S calculation.

15

If the sensitivity of the diodes 534 and 538 varies differently from each other during the treatment, then the attenuation coefficient K_S will vary. This situation will be avoided by choosing the same type of photodiode detectors 534, 538. Additionally, the photodiode sensitivity coefficient variance is typically small.

20

The blood leakage detector can be tested by varying the intensity of the light source 530 and making sure that the reference and blood sensor photodiode detectors, 534 and 538, respectively, track within limits. The supporting electronics for the blood leakage detector 428 should be low-noise with high stability. Calibration tests must be performed to determine the expected light levels detected for various dialysate flow rates and blood concentrations. The path length of the light within the cuvette determines the sensitivity of the optical density measurements.

25

As an alternative approach, instead of pulsing the light from LED 530 on and off, the light intensity can be sequenced OFF, LOW and HIGH. If a blood concentration in the

- 54 -

cuvette 536 causes a low reading near the noise floor of the electronics, the next higher detector reading corresponding to the high light source intensity can be used.

IV. The Extracorporeal Circuit Module 28

5 Referring now to FIGS. 13 and 27A, the extracorporeal circuit module 28 will be described in detail. The patient's blood is introduced into the extracorporeal blood circuit 400 in arterial line 432. If a saline bag 448 is used as discussed below, the saline is introduced into the arterial line 432 at three-way connector TC with rotating male luer lock and two female luer lock such as Haemotronics Part No. B-82 or, alternatively, a four-way
10 injection site with rotating male luer lock/double female luer lock, such as Haemotronics Part No. CR-47. The saline bag 448 is optionally provided, and is connected to the arterial line 432 by a saline infusion line S having an optional fluid/air sensor 781 and a clamp 779. The saline bag 448 has several potential uses: for priming air out of the extracorporeal circuit 400, for replacing lost fluid during therapy and rehydrating the patient, and for rinsing back
15 blood to the patient. Our reverse osmosis water and ultrapure dialysate, introduced to the extracorporeal circuit 400 by causing a pressure differential to exist at the membrane of the dialyzer, serves these functions as well, thus the saline bag 448 is for an alternate method of priming and rinseback. The fluid sensor 781 detects when the saline bag is empty, and permits automatic identification of this condition to the patient, obviating the need for
20 periodic checks of the saline bag 448. When air is sensed by the sensor 781, the clamp 779 is closed. An alternative to the use of a fluid sensor 781 is an in-line infusion filter in the infusion set which obviates the need of a fluid sensor.

A clamp 444, an ultrasonic air bubble detector 446, a pressure monitor 500A, and

- 55 -

an optional injection site (needle or needleless type) 456 are placed in the line 432. Blood pump 458 pumps blood into line 462, via special pump section tubing (from Pharmed™ material or silicone) past optional injection site 460 and pressure monitor 500B and (optional) expansion chamber 466 to the dialyzer 404. The blood is returned to the patient via line 470 to an air-separating and pressure monitoring chamber 472 having an inlet tube 471 at the top or bottom, with the top preferred.

Referring in particular to FIGS. 13 and 27A, the air-separating and pressure monitoring chamber 472 has a chamber 474, an upper and a lower blood level sensors 476 and 478 respectively, and an optional injection site 480 (one or more). A third blood level sensor 477 placed at the optimum blood level is preferably provided with the chamber 472 for monitoring or controlling the blood level. The chamber 474 is in air communication via line 482 to a connection port 483 in a disinfection manifold unit 494 (shown schematically in Figure 13), which is further connected to a line 491 having a pressure sensor, an air pump 777, a filter and then open to atmosphere. Because the fluid in the chamber 474 is normally under positive pressure during dialysis, the level may be raised (when identified as being too low by the level sensor 478) by operating the pump 777 to remove air from the chamber 472 until the level is raised to the level of sensor 476. The level may be lowered by stopping the occlusive blood pump 458, and operating the air pump 777 to add air to the chamber 472. The bottom of the chamber 474 is connected to a line 484 having an ultrasonic air bubble detector 486, a blood sensor 488 and a clamp 490 and is connected to the venous line 492 which leads to the patient.

A pressure transducer isolator (a disc shaped unit) 493 (FIG. 28) is installed at the interface between the line 482 and the port 483. The isolator 493 has a microporous

- 56 -

membrane which allows no fluid to escape out of the line 482 but which allows air to escape and enter the line 491. An alternative construction to the air pump 777 is to place an air pressure adjustment valve and a clamp in the line 491 from the port 483 which is open to atmosphere.

5 Referring to FIG. 13 and FIG. 28, the disinfection manifold 494 includes disinfection ports 495, 497 and 499. Port 495 is connected at the back side of the manifold 494 to disinfection line 496, which carries disinfection fluids (e.g., hot water) to the extracorporeal circuit 400. Ports 497 and 499 receive the connectors at the end of the venous and arterial lines 432 and 492, respectively after the dialysis session is completed. Ports 497 and 499 are connected to each other via valve V20 (FIG. 6). Port 497 and port 495 are connected via a T fitting on the back side of the disinfection manifold 494. These connections provide a path for the flow of disinfection fluid (i.e., hot water or water treated with disinfection chemicals) through the entire extracorporeal circuit 400, including the blood side of the membrane in the dialyzer 404. The port 483 is not in fluid communication with the other ports 495, 497, 499. When the dialysis session is completed, the patient reconnects the bubble trap line 482 from the port 483 to the disinfection port 495. While the disinfection manifold 494 could be formed as a unitary housing, it may also simply be composed as an array of connectors having the fluid communication pathways described herein (or equivalents). Referring now also to FIG. 6 and 28, it will be seen that lines 289A and 236A connect at the back side of the disinfection manifold 494 to ports 499, 497.

20 The back side of the disinfection manifold 494 is connected via return lines 236A and 289A to valves V14, V20, check valve CV 11 and thermistor 293 (FIG. 6). Lines 236A and 289A connect through the disinfection manifold to the venous 492 and arterial 432 lines,

- 57 -

respectively, of the extracorporeal circuit, when the lines 432 and 492 are connected to the ports 499, 497 of the disinfection manifold 494.

FIG. 27B shows the venous and arterial lines connected to their respective disinfection manifold ports, and FIG. 27C shows the lines as they would be when they are connected to the patient. The tubing connecting the ports 497 and 499 to the dialysate preparation module 26 is behind the extracorporeal circuit bulkhead.

It is common in extracorporeal blood circuits to have a blood filter which filters the blood as well as eliminates air or gas bubbles. The typical application for these filters is in major surgical procedures. The blood flow rates for these surgical procedures range from 3 to 6 liters per minute. The typical blood flow rate for hemodialysis is only 200 to 600 milliliters per minute.

It is well known that air contact with blood often causes clotting. This is one of the draw backs of traditional bubble traps. Bubble traps also require level sensors and a valving scheme and control system to allow the collected air escape. By using a hydrophobic microporous membrane to allow the air to escape passively, less clotting occurs, less sensing and valving hardware is needed, and fewer set manipulations by the patient or machine operator are needed. In addition, the unit is simpler to clean and sanitize. Thus, an alternative to the air separating and pressure monitoring chamber 472 is a cassette-type debubbler 1000, shown in FIGS. 15A-15D. FIG. 15A is an exploded view showing the front or blood side of the debubbler 1000. FIG. 15B is an exploded view showing the rear or air side of the debubbler 1000. FIG. 15C is a cross-sectional view of the debubbler 1000 through the blood outlet 1020 in an assembled condition, with the unit in a vertical orientation as it would preferably be installed in the extracorporeal circuit 400 (FIG. 13).

- 58 -

FIG. 15D is a perspective view of the debubbler 1000 partially broken away in section in the same plane as FIG. 15C. Also for this application the debubbler 1000 is designed to be cleanable, sanitizable and reusable.

Referring to FIG. 15A, the debubbler 1000 has a front cover 1002, a fluid circuit
5 board 1004, two microporous membranes having a blood contact portion 1006 and a
secondary air vent 1006A, a back cover 1008 with pressure transducer opening 1016A and
an over molded support portion 1010 having a series of parallel support ridges 1024
separated by adjacent parallel apertures 1115. The fluid circuit board 1004 has a blood
chamber 1014 and an optional pressure transducer opening 1016 disposed therein. A
10 retaining ring 504 and pressure transducer comprising diaphragm 506 with metal disk 508
are mounted within the opening 1016 for measuring the blood pressure in the blood chamber
1014. The magnet, rod and strain gauge elements of the pressure transducer are described
in construction with FIG. 14A-C below.

A condensate outlet 1018, a blood inlet 1022 and a blood outlet 1020 are provided
15 at the bottom of the fluid circuit board 1004. An air port 1012 is also provided at the
bottom for conducting air passed through the filter 1006A and 1006 out of circuit board
1004. Referring to FIG. 15B, which is a exploded view of the debubbler 1000 seen from
the rear or air side, the fluid circuit board 1004 also has a condensate chamber 1032 and
hole 1038 covered by membrane 1006A, a membrane peripheral seal area 1028 where the
20 microporous membrane 1006 is sealed to the fluid circuit board 1004, a raised rib 1026 and
a channel 1030 for collecting condensate. Condensate is passed out of the unit 1000 from
condensate outlet 1018.

It is well known that hydrophobic microporous membrane filters will allow air to

- 59 -

escape a chamber while preventing aqueous liquids to escape through the membrane. This also works with blood. PTFE, also known as TEFLON™, microporous membrane filters have been used successfully for many years. However, if blood flow is deadheaded against a PTFE microporous membrane filter, in a short period of time the membrane will become
5 coated with a biofilm that impedes air escapement. It is well known that PTFE attracts lipids and proteins. It is also well known that if the blood flow is allowed to flow past the microporous membrane in a tangential manner, the flow minimizes the build up of a biofilm and better maintaining air escape efficiency.

Prior art air venting blood filters for surgical use typically employ an essentially
10 horizontal inlet port that passes blood tangentially across a horizontal hydrophobic membrane. The blood flow across and around and then down through a blood clot filter and out. There are several variations to this theme. There are reports that claim the clot filters cause more clots than they eliminate from the flow stream. All these surgical units are designed for single use and are relatively expensive. For our hemodialysis application, no
15 clot filters will be used.

Recently, two microporous membrane manufacturers, Pall and Millipore, have introduced PVDF (polyvinylidene fluoride) also known as KYNAR™ membranes that have superior hydrophobic properties over PTFE and which reportedly do not have the protein and lipid attraction that PTFE has. PVDF is the preferred material for the membranes 1006,
20 1006A of the cassette-debubbler 1000 of FIG. 15. PVDF has the following properties: sealability to the PVDF microporous membrane, blood compatibility, natural hydrophobia, moldability, heat sealability, translucency and can be compliant under pressure. Polysulfone could also be used as an alternate material with difficulty and with a trade off in properties.

- 60 -

To achieve tangential flow, our microporous membrane filter 1006 is installed in an essentially vertical orientation. The blood inlet port 1022 is also vertical, as is the outlet 1020. The inlet port 1022 can be from either the top, bottom or side. Our preferred embodiment is having the inlet 1022 enter from the bottom.

5 The covers 1002, 1008 are heat sealed to the ribs 1027, 1026 using a heat seal process. The fluid circuit board 1004 is fabricated preferably by injection molding with ribs 1027, 1026 forming channels on both sides of a central plane 1029 of material. Three holes are provided in the fluid circuit board. The hole 1016 is for the silicone diaphragm pressure transducer. The silicone diaphragm or membrane 506 is to be captured and secured by
10 welding a retaining ring 504 over the edge of the silicone to a mounting structure 1036 on the fluid circuit board 1004.

 The hole 1034 is covered with the microporous membrane 1006 and sealed around the edges to the fluid circuit board 1004. This can be accomplished several ways. The membrane 1006 can be placed in the part and heat sealed in place at membrane peripheral
15 seal area 1028 or held mechanically in place. The preferred embodiment insert molds the membrane in place. To insure even better seal integrity, the insert molded membrane 1006 can be over molded with support member 1010. Coincident with the over molding would be the addition of suitable support ribbing 1024.

 The membrane 1006 is placed over the hole 1034 from the back side of the fluid
20 circuit board 1004 (FIG. 15B), the back side being the non-blood contact side. Placing the membrane 1006 from the back is necessary because the objective is to be able to eliminate all the air from the chamber 1014 on the blood side (FIG. 15A). If the periphery seal was accomplished from the blood side, then the seal area at the top of the chamber would be

- 61 -

higher than the active membrane area, making total air elimination impossible. Total air removal is important for sanitization purposes.

Usually, insert molded filters are designed such that the direction of flow applies force perpendicular to the peripheral seal area and against the seal area. Because of the total air removal issue, the fluid flow in this instance applies a peel force to the peripheral seal when the membrane is placed from the back. Integrity of the filter membrane 1006 and seal is dependent on the membrane strength and the peel seal strength. A second insert molding of an overseal around the periphery of the membrane 1006 is used to better secure the membrane 1006 and eliminate the possibility of the pressure exceeding the peel force strength. The membrane 1006 ends up sandwiched between two layers of plastic. With the over molding 1010 of the seal, support members 1024 are also added to further support the membrane 1006 against the flow pressure preventing distortion and possible rupture of the membrane 1006. Alternately, this can also be accomplished mechanically. The membrane filter 1006 material may or may not have a polymer screen mesh incorporated into its structure to improve membrane strength.

Blood enters the blood side of the chamber 1014 through the inlet port 1022. The flow is directed to the center of the chamber 1014 to gently disrupt the flow pattern and allow the previously entrained bubbles to contact the microporous membrane 1006 and escape. To enhance contact time with the microporous membrane 1006, the distance between the front cover 1002 of the chamber 1014 and the microporous membrane 1006 is preferably 1/8 inch or less. For typical bubble traps the volume and geometry of the chamber required is considerably larger. This is necessary in order to slow the blood flow down and give the entrained bubbles time to escape the viscous blood.

- 62 -

The back side of the fluid circuit board 1004 (FIG. 15B) manages the air that passes through the microporous membrane 1006 and condensate formed during sanitization. Air and condensate is allowed to flow into condensate region 1030 and down and out the exit port 1018 to drain via silicone tubing, a connector, a pinch valve and suitable internal machine plumbing (not shown).

Air is let in or out through the air port 1012 at the bottom of the cassette via silicone tubing, a connector, a pinch valve and suitable internal machine plumbing. Some condensate is also allowed to exit the cassette through port 1012. In the preferred embodiment of the cassette, the air will be directed through the hole 1038 back to the front of the fluid circuit board, down a channel 1040 (FIG. 15A) and out the bottom of the cassette at air port 1012. The hole 1038 is covered by a microporous membrane 1006A. This membrane could be an extension to the original membrane or a separate piece as shown. The second membrane 1006A serves as a safety mechanism. Should the primary membrane 1006 fail, the patient could suffer a potentially catastrophic loss of blood. With the secondary membrane 1006A, if the primary membrane 1006 ruptured, the blood would be stopped by the second membrane. A blood detection sensor (not shown) is provided to sense the presence of blood on the back side of the cassette and the activate an alarm and stop the machine. The blood detection sensor is similar to the blood leak detector 428 described above. Because the volume of space between the two membranes is sterile (ETO or radiation sterilization post assembly), the patient will not be at risk of infection should the primary membrane rupture.

During sanitation, if condensate occurs on the air side of the membranes 1006, it can be removed by allowing the condensate and air to exit the cassette from the bottom via port 1018 utilizing gravity. If condensate occurs on the down stream side of filter 1006A it can

- 63 -

be removed by allowing the condensate and air to exit via port 1012, Otherwise a condensate build-up could act as a shutoff valve and block all air passage in or out.

The preferred design of the connection terminals for the lines 432 and 492 is shown in FIG. 29A-C and 30A-D. A preferred design of the ports of the disinfection manifold 494 are shown in FIG. 31A-C. Referring to FIG. 29A-C, an integral inner piece or male luer with luer lock 550 is shown in an end view in FIG. 29A, a cross-sectional view in FIG. 29B, and in a elevational view with a tube 552 in phantom in FIG. 29C. The male luer 550 receives the end of a silicone tube 552 by insertion of the tube over the cylindrical tubing port 554. A secondary silicone oversleeve could also be placed over the tube 552. The male luer 550 has a locking hub 556 with threads 560 disposed on its inner surface. The connector further includes a second elongate spout or tube portion 558 integral with the wall 562 and tubing port 554. A pair of apertures 551 are provided in the side walls of the locking hub 556 to allow air to vent out of the interior of the locking hub 556. At least one aperture is needed on connectors with integral nonrotating locking hubs. The aperture can be anywhere on the locking hub shoulder.

Referring to FIG. 29D, in operation, male luer 550 locks onto female luer 559 by virtue of threaded engagement of flange 561 of female luer 559 with threads 560 of male luer 550 and rotational movement of locking hub 556 relative to female luer 559. In FIG. 29D, an alternative construction is shown in which the locking hub 556 is a separate spinning hub piece that snaps over a circumferential ridge 555. Air vents out of the hub 556 by virtue of the clearance 553 between the locking hub and the integral tube 557.

The connection terminal further includes a separate outer piece 570, shown in FIGS. 30A-D. FIG. 30A is a perspective view of the outer piece 570 prior to pushing the outer

- 64 -

piece over the male luer 550 to secure the two pieces together. FIG. 30B is an end view of the outer piece 570. FIG. 30C is a sectional view of the outer piece. The generally elongate cylindrical outer piece 570 has a housing 572 with a recessed notch portion 574 on its outer surface, a series of axially disposed raised ridges 576 circumferentially disposed on the housing, with or without spaces 577 between the ridges 576. A slanted shoulder region 578 is disposed adjacent to the end region 579 of the piece 570. The interior region of the piece 570 is dimensioned to provide compression on the tube 552 preferably 360 degrees around the tube and male luer 550 when the outer piece 570 is pressed in a friction fit over the tube and luer 550. The recesses 577 can be omitted with housing 572 smooth at the thickness of ridges 576.

Referring to FIG. 30A, the outer and inner pieces 570 and 550 are secured together by inserting the outer piece 570 over the end of the tube 552 and firmly pressing the outer piece 570 onto the inner piece 550 (see arrow, FIG. 30A) such that the interior region snugly compresses the silicone tube 552, resulting in the construction shown in FIG. 30D. Alternatively, and referring to FIG. 30E, oversleeve 583 comprising a short tubing segment can be installed over the end of the tube 552, and the interior surface 584 can have 3 or 4 longitudinal ribs 581 projecting inwardly from the interior surface 584 that securely grip the tube segment 583 and tube 552 when the second piece 570 is snugly inserted over the male luer 550.

Alternatively, the outer and inner pieces 570 and 550 could be formed as a single integral unit, with tubing port 554 extending rearwardly past the end of the cylindrical housing 572 to allow insertion of the end of the tube 552 onto the tubing port 554. See FIGS. 30F-3G.

- 65 -

A slight variation of the patient connector embodiment of FIG. 30G is shown in a perspective view in FIG. 30H, a plan view in FIG. 30I, and sectional views in FIGS 30J and 30K. The connector 570 is a one piece construction with an elongate entrance tube 554 and integral locking hub 556. The tip 558 may be recessed, even with, or extend slightly beyond the end of the connector, as shown in Figure 30J. The basic elements of the connector 570 are as described above. The connector does not have a vent hole. Cleaning of the connector in situ is accomplished by using the flow of fluid through the connector, and pulsing valves or clamps in circuit with the connector to force air out of the connector. The pressure surges are created with the UF pump and pulsing of valves in the extracorporeal circuit 400.

The connection terminal of FIG. 30D is applied to the ends of the arterial and venous lines 432 and 492. The terminals are inserted into the preferred disinfection manifold port design, shown in FIGS. 31A-C. In FIG. 31A, the connection port 499 there illustrated is the same as the other ports 497 and 495 and 483. The port 499 is shown in a elevational view in FIG. 31A, and end view in FIG. 31B, and in a sectional view in FIG. 31C. The connection terminal of FIG. 31D is installed in the connection port 499 as shown in FIGS. 31D and 31E.

Referring to FIG. 31A, the port 499 consists of a housing 632 defining axis 661 with a flange 634 for mounting the port 499 to the disinfection manifold 494 housing (or perhaps to the side of the machine if the disinfection manifold is arranged as an array of ports). Screw threads 636 are provided for accommodating a threaded nut for securing the housing 632. Six apertures 638 are circumferentially spaced about the housing 632 with steel bearings 637 placed therein. Upper and lower projection elements 640 lock the knob 641 in place when the knob 641 is pushed against the force of the biasing spring 643 in the

- 66 -

direction of the flange 634 and rotated. The notch 642 retains a retaining ring 695 for knob 641 in place. An elastomeric O-ring 650 is placed in the interior 654 of the port 494. The tube end 644 of the port 644 includes an optical detector comprising a light generation unit 646 and a sensor 648 with a lead going to CPU 610. Sensor 648 detects the presence of a connection terminal within the port 499. The position of the sensor 648 may be changed from that shown in FIG. 31A as necessary in order to detect the presence of the connector in the port, such as immediately behind the flange 634. The tube end 644 accommodates a silicone tube (such as line 289A) in the manner described below in conjunction with FIG. 24.

10 Referring to FIGS. 32A-32E, the knob 641 is shown isolated from the rest of the port 499. Knob 641 is shown in a side elevational view in FIG. 40A, with surface 699 oriented towards flange 634 and surface 645 oriented towards the outside as shown in FIG. 31. FIG. 32B is an end view of the knob. FIG. 32C is a sectional view of the knob along the line 32C-32C of FIG. 32B. FIG. 32D is an opposite end view of the knob, with recessed portions 653 fitting over projections 640 of FIG. 31A. FIG. 32E is a sectional view of the knob 641 along the line 32E-32E of FIG. 32C. Races 657 accommodate the projections 640. The outer turn of the biasing spring 643 seats against the inner wall 655 of the knob. The spring biases the knob 641 to an outer position. The knob 641 locks on to projections 640 when the knob 641 is pushed to an inner position such that the projections 640 pass into recessed portion 653, and the knob is turned such that projections are rotated into race regions 657.

20 Referring to FIGS. 31D and 31E, the connector assembly of FIG. 30D is shown installed in the port 499. To establish the connection, the user inserts the connector 550,

- 67 -

570 into the port 654. To lock the connector 550, 570 in place, the user pushes the knob 641 against spring 643 such that portion 647 is positioned over the bearings 637, pushing the bearings 637 radially inward into notch region 574 of the outer piece 570. The shoulder 578 seats against the O-ring 650, with male luer 550 projecting into the region 652 of the port 499 where it can be sensed by the sensor 648. The knob 641 is rotated clockwise over the projection 640 (FIG. 31B) into a locked position. The bearings 637 are securely positioned within the notch 574 of the outer piece, preventing removal of the connection assembly 550/570.

When the connector assembly 550/570 of FIG. 30D is installed as shown in FIGS. 31D and 31E, it will be appreciated that complete disinfection of the interior and exterior surfaces locking hub 556 is accomplished when disinfection fluids are circulated within the port 499. In particular, if the patient contaminates (as by touching) locking hub 556 or spout 558 of the male luer 550 when disconnecting from the arterial or venous lines from the fistula needle, these surfaces of the male luer 550 are subject to hot water disinfection when the connector 550, 570 is installed on the port 499 during the disinfection cycle. Moreover, by reason of the clamping engagement of the outer piece 570 onto the tube 552 and seating of the shoulder region 578 of the outer piece 570 against the O-ring 650, and the locking engagement of the outer piece 570 to the port 499, fluids will not escape past the O-ring 650 into the chamber 654.

20 The pressure sensors 500A-B of FIG. 13 are of the same design, which is illustrated in detail in FIGS. 14A-14C. FIG. 14A is a cross-section view of the sensor 500, FIG. 14B is a top plan view of the sensor 500 in an assembled condition, and FIG. 14C is a sectional view of the diaphragm element 506. The sensor 500 includes a housing 502 and a retaining

- 68 -

ring 504 which retains the diaphragm 506. The diaphragm 506 is placed opposite a wall 520. The diaphragm 506 is preferably a circular resilient silicone membrane (or the equivalent) having an upper surface 526 and a lower surface 524 in contact with fluid within the chamber 522 of the sensor 500. A circumferential retaining rim 528 integral with the upper surface 526 of the diaphragm 506 retains a metal disk member 508 on the upper surface 526 of the diaphragm. The magnetic metal member 508 is placed into contact with a magnet 510 mounted to the distal portion 514 of a rod 512. The metal member 508 may be coated to prevent corrosion or leaching of chemicals. It could also be made from plastic impregnated with metal. The metal must be magnetic. The rod 512 includes a lever member 516 connected to a strain gauge 518 that measures the back and forth movement of the rod due to the movement of the diaphragm 506 caused by pressure variations in the chamber 522. If a ferromagnet is chosen for the magnet 510, the magnet 510 is in continuous contact with the metal member 508. When the magnet 510 is an electromagnet, the magnet 510 would come into contact with the metal member 508 when the magnet is energized by an electric current.

The required magnetic force per unit area for the present application is about 11.6 pounds per square inch. For a disc 508 with a diameter of 0.441 inches, the preferred design, the required magnetic force is 1.77 lbs. The ideal force is a little greater, about 2 pounds.

The pressure sensors 500A, 500B monitor the pressure in the arterial line 432. If for some reason the arterial fistula needle gets accidentally positioned against the wall of the patient's blood vessel, the pressure will generally drop. The CPU 616 (FIG. 16) monitors the readings of sensors 500A, 500B and, if the pressure drops, it prompts the patient to

- 69 -

move about to free up the needle or adjusts the blood pump 458 to bring the pressure to acceptable limits.

The efficiency of a dialyzer in removing toxins is maximized if the dialysis time is made as short as possible. The faster clearance of urea requires a faster flow rate of the patient's blood. We achieve a faster flow rate by taking advantage of a lower limit of
5 pressure to be monitored by pressure sensor 500B that is safe for conducting dialysis. This pressure limit would be set by the patient's physician. As long as the pressure is above this limit, the pump rate of the blood pump 458 is gradually increased. If the pressure drops below the limit, the blood pump is slowed or stopped if the pressure fails to rebound. When
10 the pressure rebounds, the pump is speeded up. This feedback control of a blood pump 458 by pressure monitors in the arterial line will permit the system to generally shorten the dialysis time, to inform the patient of the expected time for dialysis, and to update the time based on any significant slowing or speeding of the blood pump 458. During this process, the pressure sensor 500A provides data in case of a malfunction in sensor 500B. Ordinarily,
15 the pressure sensors 500A and 500B have the same readings. The pressure sensors 500A-B are calibrated against the reference sensor 410 in the dialysate circuit 402 as described below in conjunction with the pressure test of the extracorporeal circuit.

The blood sensors 446 and 486 are of the same basic design as the blood leak detector, but without the beam splitter and reference photodetector. The sensors 446 and
20 486 serve two purposes: (1) to detect blood when blood is first introduced into the extracorporeal circuit 400, thereby permitting calculation of the time elapsed during dialysis, and (2) permitting automatic rinse back control by automatically ending the rinsing back of the blood when the light transmission levels detected by the sensors 486 and 446 rises to a

- 70 -

threshold value. As dialysate (or saline) is pumped through the dialyzer 404 during
rinseback, the blood concentration in the lines 432 and 492 diminishes. When the blood
concentration has been diluted to a threshold level, as determined by the blood sensors 446,
486, rinseback is deemed to have been completed. Clamps 444, 490 close, the blood pump
5 is stopped, the input and output valves 414 and 416 for the dialyzer 404 close, and bypass
valve 412 opens. During rinseback, the time and flow rate of the ultrafiltration pump 242
and blood pump 458 must be coordinated to insure equal pressure in the lines 432, 492.
Generally, the ultrafiltration pump 242 pumps at twice the pump rate of the blood pump 458.
This creates the pressure differential in the dialyzer 404 and a split flow of blood/dialysate
10 in the arterial and venous lines of the extracorporeal circuit 400. Further, by knowing the
flow rate and the volume of blood in the extracorporeal circuit 400, it is possible to
determine the time for rinseback and blood can be automatically rinsed back without
monitoring the concentration of blood in the arterial and venous lines. As another
alternative, the blood may be rinsed back with saline from a saline bag with blood
15 concentration measured in the venous line. This technique is discussed in detail below.

Leakage from the various lines and hardware components of extracorporeal circuit
module 28 out of the tubing or hardware components is indicated by a leak path 430 (dotted
lines). In use, the module 28 is placed above the other modules of the machine 22. A
suitable drain and drain tube are provided from the extracorporeal circuit module 28 to the
20 bottom of the housing of the entire machine 22, where such leakages may sensed by the fluid
sensor in the catchment basin of FIG. 6. Alternatively, a blood sensor and fluid leak
detector may be installed in the base of the extracorporeal circuit module 28 for leakage
detection *in situ*.

- 71 -

The tubing (lines) used in the various modules 20, 24, 26, 28 is preferably a silicone tubing, as silicone tubing is biocompatible, translucent, susceptible to disinfection by hot water, oxidation chemicals and other disinfecting chemicals, and has a long operational life. Note, however, for the section of tubing used in the blood pump 458 we prefer to use a
5 tubing that has superior anti-spalling characteristics, such as the PharMed™ polyolefin-based thermoplastic elastomer tubing from Norton Chemical, or the equivalent.

Silicone tubes are inert to most bonding solvents, so a way of fastening the tubes to the hardware was invented. A preferred technique for connecting the silicone tubes to the various hardware or rigid components of the machine (such as the pumps, valves,
10 thermistors, tanks, filters, etc.) is shown in FIGS. 24A and 24B. A generic silicone tube 900 is shown connected to an arbitrary piece of hardware 902 by insertion of the free end of the tube 906 over an entry port 904 for the hardware 902. To keep the free end 906 securely installed on the port 904, we use a short section of tubing 908 typically having the same diameter as the tube 900 and insert the segment 908 over the other end 901 of the tube
15 900, spread the segment 908 apart with any suitable implement such as a tubing expander, and thread the segment over the tube to the end 906 until the segment 908 covers the port 904 and end 906, as shown. An alternative method of making the clamping connection is to first thread the segment 908 over the free end 906 of the tube 900, expand the segment 908 and end 906 of the tube with a tubing expander, and place the free end 906 and segment
20 908 over the port 904.

Different wall thicknesses and diameters of the segment 908 and tube 900 may still be used. The segment 908 can be the same tubing as the silicone tube 900. This construction gives good clamping results. We have found it particularly advantageous to

- 72 -

have the segment 908 installed relative to the port 904 such that the outside end 903 of the segment 908 extends past the end 905 of the port, as shown in FIG. 24A. This construction creates a slight circumferential bulge 907 on the inside of the tube 900, preventing fluids from leaking around the edge 905 of the port.

5

V. The User Interface and Control Module 25

Referring now to FIG. 16, the user interface and control module will now be described. The module 25 includes a display 600 which displays messages and information concerning the status of the system to the patient. A touch screen 602 (or alternatively a
10 keyboard or voice-activated system) interfaces with the patient and is provided for inputting commands or information from the patient into a human interface (HI) board 608.

Indicators 604, including lights and audio indicators, and a speaker 606, alert the patient to abnormal conditions in the machine 22, and provide information as to the status of the modes of operation of the machine.

15 The module 25 includes a host central processing unit 610 connected via high speed digital data busses 611 and 613 to a driver board 612 and an analog board 614. The central processing unit 610 has an associated memory (not shown) that stores the operating software for the machine 22 and for other operational requirements, such as storing data from the sensors, and storing data input from the patients. Analog board 614 contains analog to
20 digital converters for converting incoming analog signals from the passive sensors in the machine 22 into digital signals. The driver board 612 receives commands from the CPU 610 and sends the commands to the valves, pumps, heaters, motors, and other active components of the machines (represented by 620) to cause the components to change their status, e.g.,

- 73 -

commence or cease operation or change rate, as in the case of a pump, or open and close, as in the case of a valve. The signals from the passive components 622 of the system, for example, the conductivity sensors, touch button readers, pressure transducers, thermistors, provide their inputs to the analog boards 614 and 618. The CPU 610 and driver board 612
5 together act as a controller for the active components.

Analog board 618 provides digital information on bus 617 to a safety CPU 616. Safety CPU acts as watchdog of critical system sensors, and provides enable signals to the driver 612 that allow certain driver commands to issue to the active components 620 (such as enable signals to the motor to move the spike in the chemical applicator 260 to open the
10 bottle when the correct indicator has been read on the side of the bottle). Communications between the CPU 616 and host CPU 610 are passed on data bus 609. The safety CPU 616 activates a buzzer if certain alarm conditions are present in the machine. A backup 24 volt battery (not shown) is provided in case of a power failure.

15 VI. System Operation

The operation of the constituent components of the machine 22 is controlled by a software program resident in the memory of the host CPU 610. FIGS. 17-23 illustrate in flow diagrams the individual routines and subroutines of the software (or, equivalently, operational sequences and modes of the machine 22). These routines and subroutines, the
20 inputs and outputs to the CPU, and the operation of the other modules 24, 26 and 28 of the machine 22 are described in detail in this section.

Before describing the sequences and modes in detail, the system-in-progress and self-check routines that are performed when entire machine 22 is turned on or when power is

- 74 -

restored after a temporary power interruption will be described first.

Upon power on, the machine performs self-checks necessary to ensure correct operation. If there is an error in any portion of the machine, the user is notified, as by displaying messages on the display 600, illumination of indicator or warning lights 604, or other suitable means consistent with AAMI/IEC standards. An indicator light 604 for power is preferably provided, allowing distinction between the absence of power and a system failure. It is preferred that the machine 22 be set up with auxiliary equipment, such as a fax/modem, for reporting the results or current status of the dialysis treatment to a central monitoring station, a blood pressure cuff, a scale for weighing the patient, and heparin infusion apparatus. The self check routines should determine the status of these features as well.

After the self-checks have been performed, the unit 22 performs a cycle-in-progress check to determine whether it was in mid-process (e.g., clean, disinfect, dialyze) when power was withdrawn and the backup battery had been exhausted. If the system was in mid-process and the power-off time was minimal, the system will continue the process.

If the disinfecting process was being performed, the CPU 610 can be preprogrammed to either continue or display message for operator to press "Resume". Default is that it continues, showing status. When continuing, the temperature of the system must be checked. Preferably there is a method of determining, based upon time elapsed without power and the current temperature of the device, whether the heat cycle is to be merely continued, lengthened, or completely rerun with a possible flush. The result must be that the disinfection cycle achieves the required limits of bacterial presence.

If the tank 202 was being filled, the CPU determines, based upon time elapsed

- 75 -

without power, whether the existing water should be drained or whether the fill should be continued from the existing level. If bacteriologically safe to continue from existing level, the system continues filling, showing status. If not safe, the system drains and begins filling again. Depending upon time elapsed, it may be necessary to rerun the disinfect cycle.

5 If the dialysate was being mixed, the system determines, based upon the time elapsed without power, whether the existing batch is "safe" from bacterial growth and precipitation. If not, the operator is to be notified that the batch must be discarded. Preferably, the system is user programmable as to whether this is an audible as well as visual alarm. Default is audible as well as visual. If "safe", the mixing process continues, showing status.

10 If the extracorporeal circuit was being primed, the system determines, based upon the time elapsed without power, whether the existing prime is "safe" from bacterial growth and precipitation. If not, the operator is to be notified that the prime must be disregarded, and that an entirely new batch of dialysate must be prepared. If "safe", the priming process continues.

15 If the clearance test process was being performed, the system notifies user that valid clearance test data could not be obtained (only the sophisticated user may be interested, but the treatment report given to the center should indicate the lack of clearance test data). If a short enough time period has elapsed the system will continue dialyzing against water in the blood side until a proper electrolytic concentration and temperature are assured on the
20 blood side. If too much time had elapsed, the system notifies the user that the prime must be discarded, and that an entirely new batch of dialysate must be prepared.

 If the "initiate dialysis" process was being performed, the system determines, based upon the time elapsed without power, whether the existing prime is "safe" from bacterial

- 76 -

growth and precipitation. If not, the operator is notified that the prime must be discarded, and that an entirely new batch of dialysate must be prepared. If "safe", the system continues recirculating the dialysate and maintaining its temperature.

5 If the dialyzing process was being performed, the system checks to see if bloodlines are connected to the machine. If bloodlines are connected to the machine, it determines time elapsed since removal of power. If safe time for bacterial growth, it asks if it should begin a cleaning cycle or if the user wants to reconnect. The system should only allow patient re-connection (and/or allows dialysate to be taken out of bypass) when the dialysate is at the correct temperature and conductivity. If the temperature gradient no longer allows for
10 separation (if that method is used), it must account for this in reporting of therapy adequacy. If too much time elapsed for the dialysate to be "safe", the system asks to begin a cleaning cycle. It may be programmed to begin automatically, as long as bloodlines 432, 492 are connected to the machine at 495, 497 (FIG. 13). If the bloodlines are not connected to the machine, (i.e., probably connected to the patient), the system asks the patient if they wish
15 to resume dialysis, rinse back blood, or merely disconnect. If resuming or rinsing back blood, it notifies the user that they are to verify that safety clamps are put back in operating position (i.e. not opened manually). The system also verifies the temperature and conductivity of the dialysate. If the patient is continuing treatment, the treatment continues from where it was interrupted.

20 If the rinsing back blood process was being performed, the resume procedure is the same as the dialyzing process.

If the waiting for patient disconnection process was being performed, the system checks to see if the bloodlines are connected to the machine. If not, it asks the patient to

- 77 -

disconnect. If so, the system asks to start the cleaning cycle; but it could be programmed to start cleaning automatically if the bloodlines are connected to the machine.

If the taking of blood pressure was being performed, the system begins blood pressure measurement again. The system looks to see the time elapsed since power was removed. The system may need to delay the number of minutes before retaking the blood pressure, due to rebound in the patient's body.

Referring now to FIGS. 16 and 17, after the system and in-progress checks have been performed, the system enters an idle state 702. An overview of the sequences of operation of the machine represented by FIG. 17 is described here. In the idle state 702, the machine 22 waits for a user input to commence dialysis. The machine 22 monitors the time elapsed since the last dialysis treatment. If the time since the last disinfection is greater than an experimentally validated dwell period (perhaps 48 hours), the machine enters a disinfect sequence 704. In the disinfect sequence 704, the entire machine is disinfected with hot water at a high level disinfection temperature (e.g., greater than 80 degrees C) for sufficient period of time to disinfect the machine, for example at least an hour at 80 degrees C. If the thermistors in the modules 24, 26 and 28 report temperatures of greater than 80 degrees C to the CPUs 610 and 616 for one hour, the machine initiates the prepare dialysate sequence 706. After the dialysate has been prepared, the machine commences the initiate dialysis sequence 708. When the priming of the extracorporeal circuit has been completed, the machine enters a dialyze sequence 710, where blood and dialysate are circulated to through the extracorporeal circuit and dialysate circuits 400, 402, respectively. When the ultrafiltration volume, and/or KT/V parameter and/or dialysis time objectives have been met for the dialysis session, the machine commences the rinseback sequence 712, in which

- 78 -

remaining blood in the extracorporeal circuit 400 is returned back to the patient. When this sequence has been completed, a rinse sequence 714 is performed. After the rinse has completed satisfactorily and waste fluids have been flushed from the machine out the drain line, the machine returns to the idle mode 702 and waits for a command or the scheduled
5 treatment time to occur and repeats the process.

As an alternative embodiment, the system could perform the disinfect sequence 704 after the rinse sequence 714, thereby immediately disinfecting the machine after the dialysis session has ended. After the disinfect sequence is performed, the machine would enter the idle state and wait for the next dialysis session to commence (or disinfect again if the dwell
10 period between sessions was greater than a predetermined period.

It should be further noted that after a dialysis session has been completed, the arterial and venous lines, 432 and 492 (FIG. 13) are connected to their respective ports 499, 497 of the disinfection manifold 494. This connection provides a pathway for reverse osmosis water from the dialysate preparation module 26 to be introduced into the extracorporeal circuit 400,
15 since the ports 499, 497 are connected to lines 289a and 236a (FIG. 6), linking the two modules together. This connection is important for performance of a number of specific functions relating to the extracorporeal circuit as described later.

It should also be noted that the disinfection temperature of the hot water (80 degrees C) and the time for the hot water circulation throughout the machine 22 (1 hour) is not the
20 only possible choice. The achievement of high level disinfection of fluid circuitry with water is a function of the water temperature and the length of time of hot water circulation. Generally, hotter water will require less time for circulation and cooler water more time. In practice, a high level disinfection temperature will generally be determined or selected in

- 79 -

advance and controlled by the operation of the water heater 228 in the machine and strategically placed thermistors, and the circulation time controlled by a clock in the CPU of the control module 25 and the operation of the pumps and valves of the machine.

5 **A. Disinfect Sequence 704**

FIG. 18 is detailed flow diagram for the disinfect sequence 704. During this sequence, the system decontaminates the dialysate preparation, water treatment, and extracorporeal circuit modules, 26, 24, 28 respectively, within a bacteriologically acceptable window prior to the next treatment. Reference should be made to FIGS. 5, 6, 13 and 18 in
10 the following discussion.

At step 716, the system checks to see that the chemical loading mechanism 260 is closed (i.e., the spike is in the lower position) and that the drain outlet of the machine 22 is connected to a drain source. The valve 72 in the water treatment module 24 is switched to allow water to enter the water filtration unit 84 (FIG. 5). Pressure sensor 98 is monitored
15 to see if water pressure is present at the inlet of the reverse osmosis filter 100. If the water pressure is below a specified level, an indicator or alarm is activated. The pressure drops across the primary and secondary pre-filters are calculated. If out of range, an alarm is activated. The reverse osmosis filter output valves 112, 108 and 80 are directed to drain water to the drain line 71. The feed side of the reverse osmosis filter 100 is flushed with
20 water to remove entrained air.

At step 718, the reverse osmosis filter 100 is put in a mode to create filtered water. The RO filter 100 valves are directed to bypass to drain. In a preferred embodiment, 30 degree C. heated water is passed through the filter unit 84. In an alternative embodiment

- 80 -

using a water filter 84 arrangement shown in FIG. 3D, the filter unit 84 is bypassed with a bypass valve 83 to remove air from the bypass line. Valve 81 is toggled a number of times to prime the recirculation loop (lines 110 and 116). The RO filter 100 valves are then directed to bypass to drain. The system waits until the feed : permeate conductivity ratio
5 exceeds a threshold level.

At step 720, the RO filter 100 is placed in a mode to fill the dialysate tank 202 with RO water of proper conductivity. The RO filter 100 inlet and outlet conductivity and inlet pressure are monitored and an alarm is sounded if they are out of range. The tank 202 is then filled with water, and lines 206 and 209 (FIG. 6) are primed via valve 232 in order to
10 read the proper level in the tank 202 with sensor LT. The UF pump 242 primes the dialyzer 404 via the valves 236, 414 and 416 and lines 240, 422. The valves in module 26 are then directed to prime the pyrogen/ultrafilter 234 (not through the dialyzer 404) back to the tank 202. The UF pump 242 is then stopped, and the dialyzer 404 is primed in the forward direction.

15 At step 722, the blood pump 458 is operated and the valves in the module 26 are directed to transfer water from the tank 202 through the pyrogen/ultrafilter 234 to the dialyzer 404. The similarity of the thermistor readings of thermistors 408, 293, 216, 230 are compared and an alarm is activated if out of range.

20 During steps 722 and 724, the RO filter 100 is producing RO water. The valves in modules 24 and 26 are directed to send filtered water to the tank 202. The valves of module 26 are directed so that water from the tank 202 goes through the pyrogen/ultrafilter 234 and back to the tank 202. The valves are directed so that water bypasses the dialyzer 404. The similarity of the thermistor 408, 424, 216, 230 readings are compared and an alarm is

- 81 -

sounded if necessary.

After step 724 and before step 726, a UF tank filling step is performed in which the UF tank level sensor PUH is monitored and the UF tank is filled, with sensor 288 triggering, indicating the tank 244 is full. The RO filter is stopped.

5 At step 726 a series of hot fill sequences are performed. The CPU 610 begins accumulating time data and temperature monitored via the thermistors. Valve V9 and check valve CV12 are primed using UF pump 242. The RO filter 100 is directed to produce water and fill the tank 202. The heater 228 is directed to heat water to 85 degrees C. The valves are directed so that water bypasses the filter 234 and backfilters through the dialyzer 404
10 through valve 416. The blood pump 458 is turned on in the reverse direction to recirculate water through the extracorporeal circuit 400. Heated water is sent through the chemical applicators 260 and through valve CV9. When the fluid sensor senses an adequate level in the tank 202, the RO filter 100 is directed to an idle mode. Water is directed through the filter 234 and dialyzer 404. At the end of this mode, the tank 202 contains RO filtered water
15 at a temperatures of at least 80 degrees C. During the hot fill modes, heated water is not circulated through the water preparation module 26.

 After the time in which the tank 202 is filling, a flush of the feed side of the reverse osmosis membrane is then conducted. Because the primary pre-filter 40 contains polyphosphate in the preferred embodiment, the feed side of the RO membrane will be rinsed
20 with RO water from the UF tank 244 to drain. This will prevent precipitation of the polyphosphate onto the membrane when disinfection temperatures decrease the solubility of the phosphate. The water to flush the RO membrane will come from the UF tank via valve 83 and flush all components downstream to valve 83. Next, the water remaining in the UF

- 82 -

tank will be heated prior to the circulation of heated water in the disinfection sequence.

At steps 728, the water heated to the high level disinfection temperature is circulated throughout the water treatment module, dialysate preparation module, and extracorporeal circuit module for at least an hour. The paths 3, 4, 5, 1, 2 indicate that due to the particular
5 valving and fluid line network in the machine, the water cannot be passed through every fluid circuit at once, and that certain flow paths must be primed and disinfected first before others can be disinfected. The description of the steps is provided below in the discussion of the rinse mode and FIG. 23.

Step 736 indicates that in the event that any of the thermistors report a temperature
10 of less than 80 degrees C over the course of one hour, the water is heated further and the cycle of steps 728 is repeated. As an alternative, the water could be heated additionally above 80 degrees C and the flow path affected, e.g. flow path "3", repeated a second time. As another alternative, an alarm could be activated or a chemical disinfection mode could be entered if the high level disinfection is not attained.

15 After the disinfection cycles have been performed and the disinfectant fluid is sufficiently cooled, the machine enters a drain mode 738, where fluid is directed from the UF tank 244 through the dialysate module 26 to the extracorporeal circuit and the drain line 107 in water treatment module 24. When the sensor PUH reads 0, mode 740 is entered, in which tank 202 is drained.

20 The machine then enters a fill mode 742, in which valve 108 sends water from the RO filter 100 to the tank 202. In the rinse mode steps 750, the water is circulated through the same fluid pathways as for the hot recirculation steps 728, except that the water is not heated. The entire machine is rinsed, including the chemical disinfection ports in the loading

- 83 -

platform 250, the tank 202, dialysate circuit, UF tank, etc. After the machine plumbing has been rinsed, the fluid lines are drained to the machine drain. The five steps in 750 indicate that some fluid circuits may have to be rinsed before others due to the particular valve and tubing network in the machine.

5

B. Prepare Dialysate Sequence 706

After the disinfection mode, the system enters a dialysate preparation sequence 706, described in detail in FIG. 19. At step 717, the process described with step 742 above is performed. At step 719, the RO filter 100 is placed in a produce water mode. The RO
10 alarm monitoring RO conductivity in cell 106 is activated. RO filtered water is then directed to the tank 202. Pump 212 is run at top speed in the forward direction. The tank 202 is placed in a recirculation and duration mode, in which water circulates out the tank 202 through degassing line 209, through valves V9 and 220 and back to the tank via valve 232 and line 231 and valve V15. The temperature at thermistor 230 should read a temperature
15 of 30 degrees C. The UF tank 244 is filled with 500 ml of water using the UF pump 242. The tank 202 is filled with reverse osmosis water up to the level at which chemicals are added to the tank 202, and then the RO filter 100 is turned off.

At step 721, a test of the integrity of dialysate circuit, and ultrafiltration control system, is performed. When the test is initiated, the level of water in the tank 202 is up the
20 to level of the chemical loading platform, the RO filter is in an idle mode and the arterial 444 and venous 490 clamps of the extracorporeal circuit 400 are open. The valves of module 26 are switched to direct water away from the dialyzer 404 and to isolate the tank 202. The fluid lines of the dialysate circuit 402 are completely full. This fluid circuit is a closed

- 84 -

system, with valves 414 and 416 closed with bypass valve 412 open. The ultrafiltration tank 244 contains some reverse osmosis water. The UF pump 242 is operated in the reverse direction to pump water into line 240 in the dialysate pathway. This increases the volume of water in the closed system, causing an increase in pressure. Pressure sensor 410 in the dialysate circuit 402 monitors the increase in pressure. Any failure or leakage in the system will be detected by the rate of decay in the pressure monitored by sensor 410, activating an alarm. The pressure in the extracorporeal circuit 400 is also monitored and slowly reduced with the blood pump 458.

At step 723, the pressure sensors 500A-B in the extracorporeal circuit are calibrated against pressure sensor 410 in the dialysate circuit. Pressure variations in the dialysate circuit 402 are achieved by moving volumes of fluid between the tank 202 and the ultrafiltration tank 244, with the introduction of fluid into the tank 202 causing an increase in pressure. Similarly, pressure variations in the extracorporeal circuit 400 are achieved by introducing additional volumes of fluid into the extracorporeal circuit via the dialyzer. This calibration test is advantageous in that it permits the use of disposable, off the shelf pressure transducers to be used in the extracorporeal circuit 400. It also permits high accuracy of the monitoring of the blood pressure in the extracorporeal circuit 400 during dialysis. To accomplish this, the valves are switched to direct dialysate-side fluid through the dialyzer 404 and pressure sensor 410. The valves are switched to isolate the tank 202 from the dialysate pathway. UF pump 242 is run in reverse to direct fluid from the UF tank to the dialyzer 404 and the extracorporeal circuit and to pressurize the dialysate circuit 402 to 300 mm Hg. If the pressure sensors 500A-B in extracorporeal circuit 400 fail to pressurize or the rate of decay exceeds a predetermined limit, an alarm is activated, indicating a leakage in the

- 85 -

extracorporeal circuit 400. Assuming no leakage, the pressure reading of sensor 410 is used to calibrate the pressure sensors 500A-500B in the extracorporeal circuit 400.

5 The UF pump 242 is then run in the forward direction, removing fluid from the dialysate circuit 402, and the pressures is stabilized at about 10 mm Hg. A second calibration of the pressure sensors 500A-B is then done, and gain and offset values for the sensors are determined. If a failure of the pressure sensor occurs, an alarm indicating a failure of the pressure sensors is activated. The UF pump is run in the forward direction until negative pressure is developed, and the additional calibration of the pressure sensors is performed. Additional negative pressure is generated and another calibration is performed. Then, UF pump 242 is run in reverse, the pressures are stabilized at 0 mm Hg. 10 and the tank 202 is vented to atmosphere.

At step 725, the air filter AF integrity is verified using a pressure decay test. The air filter AF is a sterile barrier membrane that filters all air entering or leaving the fluid pathways of the machine 20. The integrity is verified by filling the UF tank 244, closing 15 valve V6, and pressurizing the tank 244 to approximately 12 psi via the UF pump 242. Pressure will be monitored using the safety ultrafiltration tank pressure transducer PUS. If the pressure transducer fails to record an adequate pressure, or the decay rate is too great, the air filter is deemed to have failed the integrity test and the user is alerted of the need to replace the filter.

20 At step 727, a test of the integrity of the fibers in the dialyzer 404 is performed to insure that the dialyzer 404 does not have any leaks that will result in blood loss or contamination. We perform this test with air pressure, similar to the fashion in which the ultrafilter/pyrogen filter 234 is tested. Air is pumped by the blood pump 458 to pressurize

- 86 -

the ultrafiltration tank 244 into arterial line 432 (via disinfection manifold 494) up through the dialyzer 404 to displace any fluid through valve 414 until the fluid is substantially removed from the lumen side of the dialyzer 404. The pressure sensor 500B in the extracorporeal circuit 400 monitors the pressurization of the dialyzer 404 and the pressure decay in the line 462. If the sensor 500B fails to record an adequate pressure, or the decay rate is too great, the extracorporeal circuit is deemed to have failed the test and the user is alerted to the need to replace the extracorporeal circuit.

At step 729, the integrity of the pyrogen/ultrafilter 234 is tested. This test was described in detail above in the discussion of the dialysate preparation module 26.

At step 731, the extracorporeal circuit 400 is filled with water. The RO conductivity and pressure are monitored. The UF tank 244 is filled with approximately 1 liter of water using UF pump 242. The RO filter 100 is placed in an idle mode. RO water is directed through the dialyzer 404 from the UF tank 244 back to the tank 202 using the blood pump 458. Then, water is back-filtered through valve 416 while venous clamp 490 is pulsed to fill the air separating chamber 474 (FIG. 13). Valve V13 is pulsed to clear air from the arterial extracorporeal circuit line 432. When the UF tank 244 is empty, the clamps 444, 490 are closed and the blood pump 458 is closed.

At step 733, RO water is pumped from the tank 202 to the dialyzer 404. The dialyzer 404 is bypassed for a short period of time and then water is backfiltered across the membrane of the dialyzer 404 into the extracorporeal circuit 400 and back to the tank 202 to prime the extracorporeal circuit 400. During these steps, the blood pump 458 is run in reverse during bypass and then forward during backfiltration.

At step 735, the extracorporeal circuit 400 is flushed with fresh reverse osmosis water

- 87 -

to eliminate air and bubbles from the circuit. The automatic priming process may be implemented as a sequence of steps pre-, during, and post-dialysate preparation, depending on the most effective and efficient way to achieve priming and dialyzer clearance test requirements. A new extracorporeal circuit will be required immediately when the
5 extracorporeal circuit 400 is determined to have a leak. Unacceptable performance of the dialyzer during the clearance test will require replacement of the dialyzer prior to the next treatment. If the dialyzer clogs during treatment, it is replaced in mid-treatment.

During the prime mode 735, water is pumped through the dialyzer 404 (with valves 412, 414 closed and valves 416, 232 and V15 open). The extracorporeal circuit lines are
10 put in a recirculation mode with V20 closed. To shear any remaining bubbles from the fibers of the dialyzer 404, pressure surges (or spikes) are induced in the arterial line 432. This is accomplished by opening and closing in rapid succession the clamps 490 and 444 and varying the flow direction of the blood pump 458. Pressure is increased in the lines when the clamps are closed and the blood pump 458 continues to pump, and when the clamps are
15 opened the release of pressure within dialyzer 404 shears the bubbles from the fibers. Valve 416 is also pulsed to cause backfiltration to shear bubbles from the fibers. Priming is also assisted by periodic backfiltration of water across the dialyzer 404. The backfiltration of fluid across the dialyzer is also accompanied by the introduction of pressure pulses in the dialysate circuit 402. The pressure pulses in the introduction of fluid across the membrane
20 causes air bubbles to be sheared off the blood side of the dialyzer membrane. The air bubbles are then conducted from the blood side of the dialyzer out of the extracorporeal circuit 400 via the bubble trap air line 482. The dialysate is pumped at a high flow rate through the dialysate circuit 402, and a valve in the dialysate circuit is opened and closed

- 88 -

to thereby introduce pressure pulses in the fluid. The backfiltration may occur in synchrony with the pressure pulses introduced in the dialysate circuit 402.

The system then enters a blood pump calibration mode. Because the blood pump tubing segment will tend to take a heat set during the disinfection cycle, the blood pump 458 is calibrated before every treatment to ensure proper fluid flow rate for a given blood pump rotation rate and fluid pressure. The flow rate will be determined by a change in volume of the fluid in the UF tank 244 over the calibration time. The blood pump rotation rate will be determined by the blood pump speed and direction sensors located above the pressure transducers in the blood tubing set. An air trap vent line may need to be added to isolate the line downstream of the air trap vent line. Fluid flows from the UF tank 244 through valve 236, check valve CV12, valve 220, line 236 to V21 up through V14 to the blood pump 458. The fluid will filter through the dialyzer and return via line 240 back to the dialysate tank 202. The blood pump rate is such that the pre-pump pressure is maintained at the specific calibration pressure when the UF pump is at the specified calibration flow rate.

At step 737, the RO conductivity, temperature and pressure are monitored and the dialysate tank 202 is filled with RO water unless the level is above the level of the chemical loading platform 250. The UF tank 244 is drained. Water is pumped to the filter 234 and away from the dialyzer 404, with the water heated by heater 228 to 37 ± 1 degrees C. The tank return valve V18 is closed and water is directed from the tank 202 through valve 236 into the UF tank 244 using the UF pump 242. The UF tank 244 is filled. The tank return valve V18 is opened.

At step 739, the RO conductivity, temperature, and pressure are monitored and RO water is sent to tank 202 until the proper level for addition of dialysate chemicals is reached.

- 89 -

The bottle 270 containing powdered chemicals is pierced by the chemical applicator 260, and chemicals are purged from the bottles 270 by periodic short bursts of water from the nozzles 350 in the applicators 260 (FIG. 12). The sprayer 285 in the loading platform 250 rinses the chemicals off of the shelf of the platform 250 into the tank 202. As water is circulated
5 through the tank and outlet line 206, the conductivity sensor 426 monitors the conductivity of the solution. Additional water is added to the tank 202 as necessary. The additional dialysate chemicals in the second and third chemical bottles are released onto the platform 250 by operation of the chemical applicators 260. The liquid chemicals are added just before the fluid level reaches the level of the nozzle 352 in the applicator 260. The tank 202 is then
10 filled completely with water.

At step 741, the system enters a mix mode in which the dialysate chemicals are mixed in the tank 202. The chemicals are mixed in the tank using the process previously described. During the mixing mode, conductivity sensor 426 monitors the conductivity of the dialysate and reports the measurements to the CPU 610. A safe concentration of chemicals is
15 verified by conductivity measurements in conductivity sensor 426 and/or by sampling the dialysate in sampler 210. Preferably the dialysate is circulated from the bottom tank outlet, through the conductivity sensor 426 and back into the top of the tank 202 via sprayer 205 during the mixing process. When the conductivity of the dialysate remains constant for a sufficient period of time, the solution is deemed mixed.

At step 743, a conductivity test is performed with the purpose to verify conductivity
20 in the sensor 426. Dialysate is pumped from the tank 202 through the ultrafilter 234 and dialysate circuit 402, through bypass valve 412 and back to the tank 202. An alarm is activated if the conductivity reading is not within a predetermined range. Also, the readings

- 90 -

of the thermistors 424 and 408 are compared, and an alarm is activated if the readings of dialysate temperature are not substantially the same, indicating a failure of one of the thermistors.

At step 745, a dialyzer clearance test mode is entered. Prior to conducting dialysis,
5 the integrity of the dialyzer 404 and the diffusion rate through the membrane of the dialyzer should be checked. On average, extracorporeal circuits are reused from 12-15 times before they are discarded. In order to determine whether the extracorporeal circuit should be replaced, its clearance is tested. We perform the clearance test after dialysate chemicals have been mixed in the tank 202, and with the ultrafiltration tank 244 filled with
10 approximately 4 liters of reverse osmosis water heated to a temperature of 37 ± 1 degrees C. The dialysate temperature is about 30 degrees C, but is heated to 37 ± 1 degree C with the heater 228. The extracorporeal circuit 400 is filled with reverse osmosis water.

The machine 22 tests the clearance of the dialyzer 404 by taking advantage of several properties of the Na^+ ion: the Na^+ ion is about the same size as the urea molecule, Na^+
15 is the dominant cation in a dialysate solution, and Na^+ is very conductive and able to be monitored with precision with a conductivity monitor, such as the noninvasive conductivity cell 426 in the dialysate preparation module 26. The Na^+ ion is used as a substitute for urea. The conductivity sensor 426 measures the conductivity of the dialysate coming out of the dialyzer 404.

20 The blood pump 458 continuously pumps pure reverse osmosis water through the blood side of the dialyzer 404 (i.e., single pass). The water flows from UF tank 244 through valve V13, through line 289 and 289A to the port 499 in the disinfection manifold 494 (FIG. 13) of the extracorporeal circuit module 28, then into the arterial line 432 and

- 91 -

through the circuit 400 and dialyzer 404, out the venous line 492 to port 497 of the disinfection manifold 494, and back to the drain. Simultaneously, pump 212 pumps fresh dialysate through heater 228 where it is heated to 37 ± 1 degrees C and pumped through the dialysate circuit 402 and back to the tank 202. At the end of the dialyzer clearance mode
5 745, about 500 ml of RO water remains in UF tank 244 at a temperature of 37 ± 1 degrees C.

The measurements of conductivity are sent to the CPU 610 of the interface and control module 25. The difference in conductivity between an initial condition with the bypass valves to the dialyzer closed, and an equilibrium or stable condition with the bypass
10 valves open, correlates to a measure of the urea clearance of the dialyzer 404. As shown in FIG. 26, the conductivity measured by conductivity cell 426 drops when the process is initiated, but soon levels off. When the conductivity measured by cell 426 has leveled off, the clearance of the dialyzer 404 in units of ml of sodium cleared per minute can be calculated by the central processing unit 610. A minimum and maximum conductivity level
15 759 may be determined for the sensor 426, and if the sensor does not record a minimum conductivity below this level at steady state, a clearance test failure may be deemed to have occurred. The details of the correlation calculation between sodium and urea are set forth in the Howard et al. patent, U.S. No. 5,110,477, which is incorporated by reference herein.

An alternative method of determining whether the dialyzer needs to be replaced is to
20 compare the clearance coefficient K for the dialyzer with the value of K when the dialyzer was new. Let C_{in} = an initial conductivity measurement prior to the test, with the bypass valves closed. Let C_{out} = Conductivity on outlet side of dialyzer with the valves open, measured by sensor 426. Let $K = [(C_{in} - C_{out})/C_{in}] \times \text{flow rate in ml/min.}$ Let K_{init} = the

- 92 -

initial measurement of the clearance coefficient when the dialyzer was new. Before every dialysis session, K_t is determined as set forth above. When $K_t \leq 0.9 K_{t_{min}}$, the dialyzer is deemed to be in condition for replacement prior to the next treatment.

As a redundant safety measure, the machine 22 performs the clearance test twice
5 before conducting dialysis. If the dialyzer 404 fails both times, a replacement message is displayed at the user interface advising the user of the need to replace the extracorporeal circuit and dialyzer 404 prior to the next dialysis. The CPU 610 records a failure of the dialyzer including the clearance value and the date at which the failure occurred.

At step 747, a mixing mode is entered for the purpose of bringing the extracorporeal
10 circuit 400 and UF tank 244 fluids up to the correct conductivity. Dialysate is circulated through the UF tank 244 with the temperature controlled to 29 ± 2 degrees C. After a certain amount of time, the conductivity of the UF tank dialysate becomes stable, and an alarm is activated if the conductivity is outside of an expected range. The valves are switched to direct dialysate out of the tank 202 through the pyrogen/ultrafilter 234 through
15 the dialyzer 404 and into the extracorporeal circuit by backfiltration. The extracorporeal circuit dialysate flow is directed through the disinfection manifold 494 back to the tank 202 with the assistance of the blood pump 458. The fluid level in the tank 202 is lowered below valve V6 if necessary.

20 C. Initiate Dialysis Sequence 708

The initial conditions for the initiate dialysis sequence are the circulation of dialysate through the extracorporeal circuit at a correct and stable conductivity and temperature and the arterial and venous lines of the extracorporeal circuit are connected to the disinfection

- 93 -

manifold 494.

Referring to FIG. 20, at step 800 an initiation screen is displayed on the display 600, and the patient is prompted to initiate dialysis. The display 600 displays a patient questionnaire, seeking input from the patient, such as their current pretreatment weight, standing blood pressure and sitting blood pressure. The weight and blood pressure of the patient is taken and the data is entered into the CPU 610. After the patient assessment steps have been performed, the system verifies that the saline bag 448 in the extracorporeal circuit is connected.

The system can be preprogrammed to dialyze to the following combination of parameters:

- * target KT/V per treatment, where K is the urea clearance of the dialyzer in ml of blood totally cleared in urea per minute, T is the treatment time, and V is the volume of distribution (of urea in the patient) which is approximately equal to 58 percent of the patient's kilogram body weight.
- * Minimum treatment time, regardless of whether the KT/V target was reached in a shorter amount of time.
- * Prescribed blood flow rate, with limits on maximum arterial and venous pressures;
- * (Dry) Weights, or water removal targets, with limits also preprogrammed as a maximum rate at which fluid can be removed (weight is removed is then calculated by subtracting dry weight from preassessment weight and adjusting the additional fluid infused during prime, rinseback and at other times) or
- * Fluid to remove, for example, in an acute setting, a removal amount may be

- 94 -

required based upon infusion volumes rather than patient weight and the system will not be able to automatically calculate fluid removal from [weight minus dry weight], thus necessitating the operator to directly specify the amount of fluid to remove.

Additional prescription parameters will be set by the physician such as, particular
5 dialyzer to be used, the arterial pressure limits, venous pressure limits, fluid removal rates, dialysis flow rate range, temperature range, heparin dosage, and so on.

At step 802, heparin infusion instructions from the patient's prescription are displayed on the screen 600. After heparin is injected, the user is prompted to input an OK.

At step 804, protective system tests are performed to insure safety of the dialysis
10 process. The tests include: arterial and venous air bubble detectors, arterial and venous pressure tests (high and low), dialysate temperature and conductivity tests, and blood leak detector tests.

After these tests have been performed, the system at step 806 checks to see if the extracorporeal circuit is to be primed with saline or backfiltered dialysate. In the preferred
15 embodiment, backfiltered dialysate is used as the priming solution. If saline is used to prime the extracorporeal circuit 400, the user is prompted to begin saline prime. The user spikes the saline bag and the saline line is primed. The blood pump 458 circulates at least 500 ml of saline through the arterial and venous lines of the extracorporeal circuit, with entrained fluids being directed through the port 499 to drain. The blood pump 458 is then stopped and
20 the clamps in the arterial and venous lines are closed.

A priming fluid can also be pumped into the extracorporeal circuit by backfiltering dialysate from the dialysate circuit. Whichever priming solution is used, it may either be infused into the patient or ultrafiltered into the UF chamber following connection of the

- 95 -

patient to the extracorporeal circuit, as taught by the Twardowski U.S. Patent 5,336,165 referenced above, and as opposed to the Eigendorf patent.

The machine at step 808 prompts the user to make the arterial connection (either using needles, catheter, or other blood access method) and attach the access to the connector at the end of the arterial line 432. The venous connection is then made in similar fashion. If necessary, the user is prompted to connect line 482 to the pressure port 493 in the disinfection manifold 494. The blood pump 458 is run in the forward direction until a small negative pressure in the arterial and venous line is sensed. The extracorporeal circuit pressure alarms are enabled, the blood sensors are enabled and the arterial and venous clamps are opened. If the optional blood sensors in the arterial and venous lines do not detect the presence of blood within a predetermined time period, an alarm is activated. The level in chamber 471 is lowered with the air pump 777. After a small volume of blood has been drawn, the arterial clamp 444 is closed. The UF pump 242 is stopped and the valve V13 into tank 244 is closed. The user is prompted to confirm blood circulation. The air bubble detectors are enabled and the arterial and venous clamps are opened. The blood pump 458 ramps up to the prescribed blood flow rate.

D. Dialyze Sequence 710

Referring to FIG. 21, at step 820, just before dialysis of the patient's blood actually commences, the thermal boundary layer between old and new dialysate in the tank 202 is established in the tank 202. In the preferred embodiment, 1 to 2 liters of dialysate is heated to a prescribed temperature (e.g. 37 degrees) and introduced into the top of the tank 202 in a nonturbulent manner as described in detail above. The heater 228 controls the dialysate

- 96 -

temperature to the prescribed temperature.

The trans-membrane pressure at dialyzer 404 is adjusted to prevent any net water or dialysate transport across the dialyzer 404. Measurements of the blood pressure on the inlet and outlet on the blood side of the dialyzer 404 are made with the pressure sensors 500B and 775. (FIG. 13). The average pressure between these pressures is then computed. The pressure in the dialysate circuit is measured at pressure sensor 410, and the pressure in the dialysate circuit is adjusted to match the average pressure in the blood side of the dialyzer 404. The adjustment of pressure is accomplished by operating the UF pump 242 in either the forward or reverse direction to pump fluid into or out of the ultrafiltration tank 244 into the dialysate circuit. By using a closed loop ultrafiltration system with a substantially noncompliant tank 202, the addition or subtraction of fluid from the dialysate circuit 402 (including the tank 202) adjusts the pressure in the dialysate circuit. This pressure adjustment technique prevents any unintended fluid transport across the dialyzer when dialysis commences.

After the pressure has been adjusted across the dialyzer, the patient's blood is dialyzed at mode 822. The dialysis sequence continues until the treatment time is up or the patient requests end of treatment. As the UF tank 244 is filled with the predetermined ultrafiltration volume for the dialysis session, the measurement of the volume of water removed from the patient is made by the level sensor PUH. As the patient's blood fills the air separating and pressure monitoring chamber 472, the level of the air separating and pressure adjusting unit 472 may be adjusted. The optional blood detectors 446, 477 and 486 detect presence of blood in the extracorporeal circuit. Once blood flow has been achieved and venous and arterial pressures have been stabilized, the system remains in dialysis

- 97 -

sequence until the treatment is complete or stopped by the user. The time of dialysis is measured and time remaining for the session may be displayed to the patient.

During the dialysis process, the membrane of the dialyzer 404 in the extracorporeal circuit 400 may be periodically backflushed (step 824) with fresh dialysate to remove any
5 build-up of organic materials on the blood side of the membrane. This procedure increases the efficiency of the dialyzer 404, avoids the buildup of blood products in the dialyzer and prolongs the life expectancy of the dialyzer 404. The blood products building up on the membrane are momentarily forced off the blood side of the membrane by the dialysate flowing into the extracorporeal circuit 400, and then, when the back flushing ceases,
10 incorporated into the blood flow, where they are carried out of the extracorporeal circuit 400 and back to the patient.

To accomplish backflushing of the dialyzer, fresh dialysate is taken from the tank 202 and passed through valve V9 up through the ultrafiltration pump 242, which is operational in the reverse direction. Dialysate is pumped out valve 236, through CV12, up line 223 and
15 226 to the pyrogen/ultrafilter 234 and up to the dialysate circuit 402 and into the dialyzer 404 with valve 414 open and valves 412 and 416 closed. During this time, the blood pump 458 is slowed. The backfiltration of dialysate through the dialyzer 404 preferably are between 15 and 30 seconds in length. The backflushing can be periodic during dialysis, or may occur one time or not at all. After the backflushing is completed, the UF pump 242
20 is stopped, valves 414 and 416 are closed and bypass valve 412 is opened, the blood pump 458 is ramped up to normal speed, the dialysate pump 212 is started again at the prescribed speed, valve 412 is closed and valves 414 and 416 are opened, the UF pump speed is recalculated and the UF pump is started up again in the forward direction at the proper rate.

- 98 -

The above-described technique differs from that described in the Eigendorf patent, U.S. No. 5,259,961. In the '961 patent, flushing of dialysate through the dialyzer is described as for the purpose of flushing and filling the extracorporeal circuit.

5 A saline reinfusion at step 828 may be performed during dialysis to add saline solution to the blood returning to the patient rehydrate the patient if needed.

10 During the dialysis process, the CPUs 610, 616 in the control module 25 for the machine continuously monitor the various sensors (temperature, pressure, conductivity, air, blood, flow rate, UF tank level, etc.) in the various modules 24, 26 and 28. Any errors in the monitoring and controlling of the various systems is controlled by an exception handling routine which would take appropriate action to recover the operation or notify the user of abnormalities. Additionally, prior to treatment, the patient's blood pressure is taken and the updated blood pressures are logged in a treatment log. When the treatment is complete, the message is displayed to the user and if the user desires more treatment the system continues to perform the dialysis. After the treatment is complete, or error conditions exist which cannot be recovered, the dialysis is stopped and the system enters a rinseback sequence (FIG. 15 22).

E. Rinseback Sequence 712

20 The rinseback sequence 712 is illustrated generally in FIG. 22. When the dialysis session has been completed, the touch screen 602 in the central control module 25 displays a prompt to the patient asking whether the patient wishes to have the remaining blood in the extracorporeal circuit rinsed back to the patient. The blood pump 458 is also stopped. Other initial conditions are that the UF pump 242 is off, the blood pump 458 is on at the

- 99 -

prescribed speed and the dialyze alarms are still active.

At mode 832, when the command to continue is received, dialysate is pumped through the dialyzer 404 and the tank 202 may be pressurized to equal the starting pressure measured at pressure sensor 410. Bypass valve 412 is opened and valves 414 and 416 are
5 closed. The blood pump 458 is stopped. The arterial and venous line clamps are closed.

At step 838, the system determines whether a dialysate or a saline rinse is to be performed. Preferably, a dialysate rinse is performed. If dialysate rinse is performed, the system enters a mode 834. In this mode, the heater 228 is turned off, pump 212 is stopped, and the valves in the module 26 are switched to direct dialysate from the tank 202 to the
10 dialyzer 404 inlet line 414 via the UF pump 242. The arterial and venous clamps are opened. The blood pump 458 is pumped in reverse at one half the UF pump rate. The UF pump 242 pumps dialysate from the dialysate circuit through the dialyzer 404 into the extracorporeal circuit 400, pumping blood in the extracorporeal circuit 400 in equal volumes out the arterial and venous lines 432, 492 back to the patient. In an alternative embodiment,
15 if the rollers of the blood pump 458 are automatically retracted (essentially shutting off the pump but allowing fluid to flow through the arterial line), then only the UF pump only needs to be used. The flow of dialysate through the dialyzer is split into two paths of even flow rates through the arterial and venous lines.

The optional optical sensors 446 and 486 in the arterial and venous lines 432, 492
20 sense the concentration of blood in the lines 432, 492 as the blood is being pumped from the extracorporeal circuit back to the patient. The sensors 446 and 486 issue signals to the CPU 610 in the control module 25. The CPU monitors the signals and when the signals indicate the concentration of blood in the lines has reached a predetermined threshold level, the blood

- 100 -

pump 458 is stopped, thereby preventing excess fluids from being returned to the patient. Alternatively, the optical sensors could be dispensed with and the patient or nurse could visually inspect the arterial and venous lines for completeness of rinseback and manually stop the rinseback procedure.

5 When the pressure in the extracorporeal circuit 400 is stabilized, the arterial and venous clamps 444 and 490 of the arterial and venous lines 432 and 492, respectively, are closed. A user disconnect message is displayed and the patient reconnects the ends of the arterial and venous lines 432, 492 to the ports 499, 497 respectively, of the disinfection manifold 494. The patient also removes line 482 from port 483 to port 495. The optical
10 sensors 648 (FIG. 31C) in the disinfection manifold confirm whether the lines are reconnected to the disinfection manifold 494. The lines are pressure tested to ensure that they have been properly replaced on the disinfection manifold ports.

 The user is prompted to install new chemical bottles 270 onto the chemical applicators 260. The readers for the machine-readable identifiers (such as touch buttons) on the bottle
15 send bottle information to the CPU 610, which then alerts the user if the wrong bottle is installed. A message is then displayed to the user to connect the water inlet and drain outlet of the machine to water inlet and drain lines (if not already so connected). A comparison check is done with the pressure transducers 76 and 92 in the tank module 26 to verify that the drain lines of the machine are connected to drains.

20 The user is then prompted to take water samples from the sample removal ports in the water pretreatment module 20, test for chlorine or chloramines, and, if necessary, change the filter unit 40. After the user has inputted an "O.K." response that the chloramine test was passed, the rinseback mode is ended and the machine enters a clean and rinse mode.

- 101 -

If saline rinse is performed (mode 836), the heater 228 is turned off, the dialysate pump 212 is turned off, and a message is displayed to insert the arterial fistula needle into the saline bag. The arterial air bubble detector is disabled. The blood pump 458 is run in the forward direction, pumping saline through the arterial line 432 and blood and saline out
5 venous line 492. The dialysate valves are directed away from the filter 234 back to the tank 202. When the blood concentration sensed by venous blood sensor 486 or saline volume has reached a predetermined limit, the blood pump 458 is stopped, the pressures in the extracorporeal circuit are stabilized and the arterial and venous clamps are closed. The user is prompted to disconnect from the machine and the process continues the same as for the
10 dialysate rinse mode 834 above.

After completing rinseback, the machine enters a clean dialyzer mode 862. Our preferred technique for on-line, *in situ* dialyzer cleaning is to use automatic hot water agitation of the blood and dialysate sides of the dialyzer membrane, followed by flushing of the dialyzer. No chemicals are used. The blood circuit is further not subjected to airborne
15 bacteria. The hot water agitation involves heating RO water (or physiologic dialysate) with heater 228 to a temperature of between 35° to $90^{\circ} \pm 5^{\circ}$ C, introducing the heated water into the extracorporeal circuit via the disinfection manifold 494 or dialyzer membrane, and introducing pressure pulses in the extracorporeal circuit and dialyzer in the manner described above in connection with the dialyzer prime mode 735. We further back flush RO water or
20 dialysate across the dialyzer from the dialysate side to the blood side of the membrane with pressure pulses introduced in the dialysate circuit 402. The particulate matter, blood products and other material which may be adhered to the fibers in the dialyzer 404 are thereby removed from the surface of the fibers. By periodically flushing the extracorporeal

- 102 -

circuit with RO water or dialysate and returning the fluid to the drain during this process, the life expectancy of the dialyzer 404 is substantially prolonged.

In particular, backfiltration of the dialyzer 404 is accomplished by clamping valve 416 and opening valve V14 to drain. The blood pump 458 is started in a reverse direction at approximately 1/2 the rate of the UF pump 242 using the dialysate which provides a physiologic solution to keep the blood products from clotting and forming more difficult substances to remove. The flow rate of the UF 242 and blood 458 pumps is limited by the maximum pressure at pressure transducer 410. The system will adjust the flow rates until either flow meter 241 reaches the preset maximum flow rate, approximately 500 ml/min, or pressure transducer 410 reaches the preset maximum pressure. The flow rate measurement by flow meter 241 can be stored by the central processing unit 610 and can be correlated to the amount of fiber blockage in the system, i.e. the lower the initial flow rate, the greater the amount of blockage. If the flow rate does not reach a specified level of approximately 500 ml/min after the time allotted for backflushing, then the dialyzer can be identified as too blocked for usage by the central processing unit 610. The user will then be alerted at the beginning of the next treatment that the extracorporeal circuit needs to be replaced before dialysis can continue.

Systematic forward and reverse flowing of the fluid in the extracorporeal circuit is accomplished by driving the blood pump 458 in a forward or reverse direction with the valves V14, 414, 416 closed and V20 open. This isolates the extracorporeal circuit 400 from the rest of the dialysis system and allows the fluid to be recirculated to scrub the residual blood products out of the extracorporeal circuit. This forward and reverse flow is continued for a preset time. At the end of the cycle, the fluid in the extracorporeal circuit

- 103 -

400 with the removed blood products is set to drain by opening V14, and backflushing the dialyzer as outlined above. This procedure can be repeated as many times as desired.

F. Clean and Rinse Sequence 714

5 The clean and rinse mode 714 is illustrated in FIG. 23. At drain A mode and step 850, the dialysate in the dialysate preparation tank 202 and UF tank 244, and their associated fluid circuits, are drained from the machine.

10 At step 852, a fill mode is entered in which the RO filter 100 sends water to the tank 202. In rinse mode steps 854, 856, 858, 860, 862 and 864, the water is circulated through all the fluid pathways of the machine. Rinsing is necessary to remove dialysate salts after treatment, remove organic blood-products after treatment, remove possible cleaning chemicals prior to the next treatment or remove possible pyrogens after disinfection, prior to treatment. Similar to disinfection, where all fluid pathways are subject to disinfectant fluid for a minimum time, all dialysate and extracorporeal circuit fluid pathways are rinsed
15 with RO water for a minimum time. The easiest rinse process from a programming standpoint is to rerun the disinfection process without heat until a sufficient time has elapsed. A summary of the five rinse steps Rinse 1-5 is as follows:

20 Rinse 1: Rinse the interior of the dialysate tank 202 using the spray nozzle 205 at a flow rate of 1000 ml/min or more. The UF tank 244, line 231 and the deaeration filter in line 209 may rinse concurrently.

 Rinse 2: Rinse the interior of the dialysate tank 202 using the spray nozzle 205 at a flow rate of 1000 ml/min or more. The UF tank 244, line 231 and the level sensor in line 206 may rinse concurrently. At the same time fluid may be backfiltered through the

- 104 -

dialyzer 404 via valves 414 and 416. The fluid backfiltered through the blood tubing set is returned to the dialysate tank 202 through valve V14 and valve 21. If the UF pump pulls fluid through line 238, the air from the dialysate side of the dialyzer and the "dialysate" side of the ultrafilter will be removed. This will allow RO water to rinse the surfaces where the
5 air was collected.

Rinse 3: Rinse the bypass valve 412 and the diffuser nozzle 243. The UF pump 242 may pull fluid through line 238; the air from the "dialysate" side of the ultrafilter will be removed. This will allow RO water to rinse the surfaces where the air was collected.

Rinse 4: Rinse the sealed surface of the chemical bottles and the seal to the
10 dialysate tank via line 283.

Rinse 5: Rinse the drain line of the chemical bottle piercing mechanism (line 281). RO water from the UF tank may be used to rinse line 289 and the blood tubing set. This fluid can be returned to the dialysate tank 202 via valve V14 and valve V21.

Any remaining fluid pathways that were not yet rinsed will be rinsed when the tank
15 202 and/or the UF tank 244 are drained. Note that the rinse sequence will usually be performed twice prior to the start of the next operational activity. Rinsing twice will minimize residual byproducts from accumulating on the fluid pathway surfaces during the draining activities. After the machine plumbing has been rinsed, the fluid lines are drained to the machine drain. At step 868, the tank 202 is drained. The waste water is pumped out
20 drain line 71 to drain output 51. After the clean and rinse mode of FIG. 23 has been completed, the machine either enters an idle mode or performs a disinfection between treatment if the elapsed time between disinfection is greater than a predetermined limit.

- 105 -

VII. Auxiliary Functions of Machine 22

Preferably, the machine 22 has the capacity for automatic communication of a treatment report to a central station or other entity monitoring the patient's hemodialysis. The treatment report could be given real time during dialysis, or after the session is over.

5 This would normally be accomplished by including in the machine 22 a fax modem connected to a phone line that is programmed to automatically fax a report of the hemodialysis treatment to the center (or to any other location, such as the physician's office or to a home computer). The treatment reports would include such information as the patient's name, address and phone number, the date and time of the report, the pretreatment

10 weight, blood pressure, pulse and temperature, a dialysate code, conductivity measurements and clearance, heparin information, and the results of periodic measurements during dialysis such as blood flow rate dialysate flow rate, arterial pressure, venous pressure, blood pressure, pulse, UF rate, total UF volume and additional comments. Additional information which may be included would be the occurrence of incidents such as when blood flow was

15 stopped, at what time, when it was resumed, and any alarms that occurred. Additional information would include the time the treatment was ended, the total dialysis time and the calculated KT/V for the treatment. Finally, treatment reports could include the post-treatment weight, post-treatment blood pressure, and answers to post-treatment assessment questions. Weekly treatment summaries, in numeric and graphical form, of the fluid

20 removed, KT/V and blood pressure would also be provided. The interface and control module 25 would be provided with internal data retention and storage capacity (such as a hard disk drive) for storing such information (such as a random access memory) until the data is later sent to a center. Equipment for local print-out for the treatment report is a

- 106 -

further possible accessory for the machine 22.

Preferably, the user interface and control module 25 for the dialysis machine 22 includes a software diagnostic routine which can be accessed from the user interface to check the various sensors in the unit 22 and to manipulate its activity. Ideally, the diagnostic routine will be able to be accessed remotely by a modem such that service entity for the machine 22 can check the sensors, failure codes and other diagnostics in the machine 22 remotely. Since the various modules 24, 26, and 28 of the unit 22 are modular, failures or servicing of the various modules in a relatively easy by replacing or swapping modules 24, 26 or 28.

From the foregoing description it will be appreciated that the inventive techniques, flowpath and system components and subcomponents may be used to provide hemofiltration and hemodiafiltration. Hemofiltration with pre-dilution is accomplished as follows. The output of the dialysate tank 202 will be directed as before through the dialysate filter (pyrogen/ultrafilter) 234. However, the output of the dialysate filter 234 will be directed to a second depyrogenation filter 404A, the output of which will be directed via T connector 404T into the extracorporeal blood circuit 400 upstream of the blood inlet of the dialyzer 404. Dialysate line 418 is blocked off as shown. See FIG. 33. The closed volume principle which allows the control of ultrafiltration in normal dialysis will also apply here such that any solution directed into the blood circuit 400 will be pulled back into the dialysate tank 202 through the dialyzer outlet line. The ultrafiltration pump 242 may still be used to remove excess fluid.

For hemofiltration with post-dilution, the technique is the same as for hemofiltration with pre-dilution, but the output of the second depyrogenation filter 404A will be directed

- 107 -

into the blood circuit 400 following the blood outlet of the dialyzer 404 at T connector 404T.
See FIG. 34.

For hemodiafiltration with post-dilution, the technique is the same as for
hemodiafiltration with pre-dilution, except that the output of the second depyrogenation filter
5 404A is directed via T connector 404A to the blood circuit 400 downstream of the outlet of
the dialyzer 404. See FIG. 35. A valve 414' and penstaltic pump 404P are placed in
dialysate line L. Line 418 is open via valve 414.

For hemodiafiltration with mid-dilution, in this implementation there is no second
depyrogenation filter. Instead, the ultrafiltration pump 242 is used to backflush ultrapure
10 dialysate into the dialyzer 404 and then to remove this excess fluid. See FIG. 35.

A further additional aspect of the invention is that the use of the tank 202 (which may
be the same size or smaller) and the same chemical mixing approach described herein, but
to prepare a more concentrated batch of dialysate which can be proportioned with the reverse
osmosis output water during the dialysis treatment. This would be particularly useful in
15 longer treatments. The same size tank or a smaller tank 202 maybe used. However, rather
than mixing up a fully dilute batch of dialysate, a concentrated batch of dialysate is prepared
(using the same chemical addition principles as described in conjunction with the discussion
of the dialysate preparation module 26). This batch may then be proportioned with reverse
osmosis product water during the dialysis session to achieve longer treatments without
20 enlarging the size of the tank required. The incoming reverse osmosis water will be heated,
and there is a means for insuring that the concentrated dialysate solution and the incoming
reverse osmosis water are thoroughly mixed. The incoming reverse osmosis water can be
heated such as by the use of temperature controlled mixing valve in the water pretreatment

- 108 -

module 20. The means for insuring that the concentrated dialysate and the incoming reverse osmosis water are thoroughly mixed can be achieved by monitoring the conductivity of the solution as the concentrated dialysate is taken out of the tank 202 past through conductivity sensor 426 and returned to the top of the tank in conjunction with the mixing principles
5 discussed above.

VIII. Conclusion

From the forgoing detailed description, it will be apparent to a person of ordinary skill in the art that many variations and modifications of the preferred and alternative
10 embodiments of the invention may be made, without departure from the true spirit and scope of the invention. The term "module", as used herein and in the claims, is intended to be broadly interpreted as encompassing a component or group of components that perform a specified function, such as treat water or prepare a dialysate solution, whether or not such component or group of components is physically encased within a housing physically apart
15 from other components. Obviously, the selection of components that comprises a "module" is a matter of design choice. For example, the dialysate circuit 402 is shown as part of the dialysate preparation module 26, but could just as easily been made part of the extracorporeal circuit module 28, with suitable connectors in the lines leading to and from the dialysate side of the dialyzer. The true spirit and scope of the invention is defined by
20 the appended claims, to be interpreted in light of the forgoing specification.

Further, the term "purified water" used herein means water in which impurities have been removed. The technical definition of "purified water", such as found in the United States Pharmacopoeia, is not intended.

- 109 -

We Claim:

1. Water pre-treatment apparatus for a dialysis machine, said dialysis machine having a water inlet, comprising:

5 a temperature-controlled mixing valve having hot and cold inlets for receiving hot and cold water from a water source water and having an outlet through which warm water flows at a pre-determined temperature;

a water filtration unit in fluid communication with said outlet of said mixing valve; and a fluid line for supplying warm, filtered water from said water filtration unit to said water inlet of said dialysis machine.

10

2. The water pre-treatment apparatus of claim 1, wherein said dialysis machine further comprises a drain outlet, and a conduit means for supplying drain fluids from said drain outlet of said dialysis machine to said water pre-treatment apparatus; and

15 wherein said water pretreatment apparatus further comprises a fluid line in communication with said conduit a carrying said drain fluids to a drain.

3. The water pre-treatment apparatus of claim 1, further comprising a pressure regulator in said fluid line.

20

4. The water pre-treatment apparatus of claim 1, further comprising a sample removal port downstream of said water filtration unit for permitting removal of water in said fluid line for sampling the water for the presence of chlorine or chloramines.

- 110 -

5. A method of disinfection of a dialysis machine having a water treatment module, an extracorporeal circuit and a dialysate circuit, comprising the steps of:

circulating water heated to a high level disinfection temperature below the boiling point of said water through said water treatment module, extracorporeal circuit and dialysate circuit for a sufficient time to achieve a high level disinfection of said machine.

6. In a dialysis machine having a water treatment module, a dialysate circuit circulating dialysate to a dialyzer, and an extracorporeal circuit transporting body fluids from a patient to said dialyzer and back to the patient, a method of disinfecting said water treatment module, dialysate circuit and an extracorporeal circuit against bacteriological substances without the use of chemical cleaning agents, comprising the steps of:

filtering water in said water treatment module through a reverse osmosis filter;
heating said filtered water within said dialysis machine to a predetermined disinfection temperature below the boiling point of said filtered water;
circulating said heated, filtered water through said water treatment module, dialysate circuit and extracorporeal circuit for a sufficient amount of time at or above said high level disinfection temperature to achieve high level disinfection.

7. The method of claim 6, further comprising the steps of:

monitoring the temperature of said heated, filtered water in each of said water treatment module, dialysate circuit and said extracorporeal circuit during the circulation of said heated, filtered water.

- 111 -

8. The method of claim 7, further comprising the step of activating an indicator on said machine in the event that said monitored temperature of said water drops below a predetermined threshold temperature anywhere in the flow path of said heated water.

5 9. The method of claim 8, wherein said step of circulating said heated water comprises the step of circulating heated water sequentially through different flow paths in said machine, and wherein the method further comprises the step of repeating said sequential circulation of heated water through said flow paths in the event that the temperature of said heated, filtered water being circulated in any of said water treatment module, dialysate circuit or
10 extracorporeal circuit during the circulation of said heated, filtered water falls to or below a predetermined threshold temperature.

10. The method of claim 5 or claim 6, wherein said machine prepares a batch of dialysate in a tank from chemicals housed in one or more batch chemical vessels, and
15 wherein said step of circulating said heated water further comprising the step of circulating said heated water to at least a portion of said batch vessels, thereby disinfecting at least a portion of said batch vessel, said portion of said batch vessel disinfected being the location of where said batch vessel is opened to release said chemicals into said tank, thereby insuring disinfection of the interface between said chemicals and said tank.

20

11. The method as claimed in one of claims 5, 6 or 10, wherein said high level disinfection temperature is at least about 80 degrees C.

- 112 -

12. Apparatus for establishing fluid connection between an extracorporeal circuit and a source of disinfection fluids, said extracorporeal circuit comprising a dialyzer, an arterial blood line and a venous blood line, comprising:

5 a disinfection line for carrying disinfection fluids from said source of disinfection fluids to said extracorporeal circuit;

a disinfection manifold comprising a first and a second port; said first port for receiving said arterial line, said second port for receiving said venous line;

a return line establishing a fluid connection with said disinfection manifold and carrying disinfection fluids from said extracorporeal circuit;

10 whereby disinfection fluids passed into said disinfection manifold by said disinfection line are routed through said arterial and venous blood lines and out of said extracorporeal circuit via said return line.

13. The apparatus of claim 12, wherein said disinfection fluid comprises water heated to
15 a predetermined high level disinfection temperature.

14. The apparatus of claim 12, wherein said disinfection manifold further comprises a third port receiving said disinfection line, wherein said third port is in fluid communication with at least one of said first and second ports.

20

15. The apparatus of claim 14, wherein said disinfection manifold comprises a fourth port in air communication with a line having an air pressure adjustment valve and a clamp, said fourth port in fluid isolation from said first, second and third ports.

- 113 -

16. The apparatus of claim 14, wherein said disinfection manifold comprises a fourth port in air communication with a line having an air pump, said fourth port in fluid isolation from said first, second and third ports.

5 17. Apparatus for directing disinfection fluids to and from an extracorporeal circuit, said extracorporeal circuit comprising an arterial line and a venous line, comprising:

first, second and third ports, said first and second ports adapted for receiving said arterial and venous lines, respectively;

fluid passages establishing fluid connection between said first and second ports; and

10 said third port having means for receiving a disinfection line for containing a disinfection fluid;

said disinfection line in fluid communication with at least one of said first or said second port, the other of said first and second ports in fluid communication with a line for conveying disinfection fluid circulated through said arterial and venous lines out of said extracorporeal circuit.

15

18. The apparatus of claim 17, wherein said apparatus further comprises a fourth port and an air pressure adjustment line having an air pressure adjustment valve and a clamp in air communication with said fourth port, said fourth port in fluid isolation from said first, second and third ports.

20

19. Apparatus for supplying a batch of chemicals stored in first, second and third vessels to a dialysate tank, comprising:

- 114 -

a housing in communication with said tank;

a first port in said housing through which a first dialysate chemical passes from said first vessel into said housing;

5 a second port in said housing through which a second dialysate chemical passes from said second batch vessel into said housing;

a third port in said housing adapted to receive said third vessel, said third vessel containing a substance selected from the group of substances consisting of dialysate chemicals, salts, nutritional supplements, medications, cleaning agents and disinfecting agents.

10

20. Batch dialysate preparation apparatus, comprising

a vessel storing a batch quantity of dialysate chemicals;

a dialysate preparation tank receiving said batch quantity of dialysate chemicals along with water to form a batch quantity of dialysate; and

15 means associated with said tank for automatically introducing said batch of chemicals from said vessel into said dialysate preparation tank.

21. The apparatus of claim 20, wherein said means associated with said tank further comprises means for receiving at least two vessels and means for automatically opening said
20 two vessels, permitting said chemicals to be introduced into said tank.

22. Apparatus comprising:

a bottle containing a unit batch of chemicals for treatment of a medical condition, said

- 115 -

bottle adapted to be installed in communication with a tank for delivery of said unit batch of chemicals automatically into said tank: and

a machine-readable indicator containing coded information as to the contents of said bottle, said machine-readable indicator applied to said bottle in a manner for permitting
5 machine identification of the contents of said bottle,

whereby machine identification of the contents of said bottle occurs prior to introduction of said chemicals into said tank.

23. The apparatus of claim 22, wherein said unit batch of chemicals comprises chemicals
10 for treating renal failure.

24. The apparatus of claim 22, wherein said tank comprises a dialysate preparation tank and said bottle is mounted to a chemical applicator prior to release of said chemicals into said dialysate preparation tank, and wherein said machine-readable indicator comprises a
15 touch button applied to said exterior surface of said bottle, said touch button positioned on the exterior surface of said bottle such that when said bottle is mounted to said chemical applicator, said touch button is placed in touching contact with a reader for said touch button.

20 25. The apparatus of claim 24, wherein said bottle further comprises a semicircular rim and a retaining bead securely retaining said touch button to said exterior surface of said bottle.

- 116 -

26. The apparatus of claim 22, wherein said bottle comprises a polypropylene cap engageable with a bottle shell, wherein said bottle shell is made from polyethylene, and wherein said cap further comprises a threaded region applied to the exterior of said cap for mounting said bottle to said chemical applicator.

5

27. The apparatus of claim 22, wherein said machine-readable indicator comprises a bar code applied to the exterior surface of said bottle, said bar code positioned such that when said bottle is mounted to a chemical applicator, said bar code is oriented in alignment with a reader for said bar code.

10

28. The apparatus of claim 22, wherein said machine-readable indicator comprises a magnetic strip applied to said exterior surface of said bottle, said magnetic strip positioned such that when said bottle is mounted to a chemical applicator, said magnetic strip is oriented in alignment with a reader for said magnetic strip.

15

29. The apparatus of claim 22, wherein said machine-readable indicator comprises a two or three dimensional matrix containing coded information.

20

30. The apparatus of claim 22, wherein said machine-readable indicator comprises a radio-frequency transmitter, said radio-frequency transmitter storing coded information as to the chemicals in said vessel.

31. The apparatus of claim 22, wherein said unit batch of chemicals comprises a dialysate chemical.

- 117 -

32. The apparatus of claim 22, wherein said unit batch of chemicals comprises a cleaning or disinfecting agent.

5 33. The apparatus of claim 22, wherein said vessel further comprises a seal made from polypropylene.

34. The apparatus of claim 22, further comprising means for automatically removing said touch button from said bottle during removal of said bottle from said chemical applicator.

10 35. A chemical application system for applying chemicals into a dialysis tank comprising:
at least one bottle containing dialysate chemicals and having an exterior surface with
a removable machine-readable indicator affixed thereto;

a chemical applicator in communication with said tank, said chemical applicator
including a spike movable between upper and lower positions;

15 said chemical applicator further comprising means for mounting said bottle to said
chemical applicator;

means for removing said removable indicator from said bottle.

20 36. The system of claim 35, further comprising catchment means for catching and
collecting said removed machine-readable indicator.

37. The apparatus of claim 35, wherein said removable machine-readable indicator
comprises a touch button.

- 118 -

38. In a dialysis system comprising a chemical applicator for introducing dialysate chemicals into a dialysate preparation tank, a method for automatically identifying the contents of a vessel containing batch dialysate chemicals prior to the introduction of said chemicals to said tank, comprising the steps of:

5 applying a machine-readable indicator to said vessel, said indicator containing coded information as to the contents of the chemicals within said vessel;

 mounting said vessel to said chemical applicator such that said machine-readable indicator is positioned in a location for reading said indicator;

 reading the indicator and decoding said information as to the contents of the bottle;

10 comparing said decoded information with stored information as to the proper dialysate chemicals for the patient;

 alerting the patient if the vessel contains improper dialysate chemicals, thereby allowing the user to replace said vessel with a vessel containing proper chemicals; and,

15 after a vessel containing proper chemicals has been mounted to said chemical applicator,

 introducing the chemicals into said tank.

39. A method for maintaining separation of old and new dialysate in a batch dialysate preparation tank, comprising the steps of:

20 storing said new dialysate in said tank at a first temperature;

 withdrawing said new dialysate from the bottom of said tank;

 returning old dialysate to said tank at the top of said tank at a second temperature warmer than said first temperature in a manner so as to substantially prevent turbulence of

- 119 -

said old dialysate during the return of said old dialysate to said tank;

introducing dialysate into said top of said tank at a temperature greater than said first temperature prior to the return of said old dialysate to said tank, thereby establishing a temperature gradient of dialysate in said tank with said warmer introduced dialysate forming
5 said first zone at the top of said tank, said old dialysate being returned to said tank and mixing with said introduced warmer dialysate in said first zone;

the temperature differential between the first and second temperatures of dialysate causing old and new dialysate to be maintained in substantially discrete zones with said old dialysate in a first zone above the new dialysate in a second zone with a boundary
10 therebetween, said boundary lowering as dialysis of the patient proceeds.

40. The method of claim 39, wherein said tank is provided with heating elements in the upper region of said tank, said heating elements assisting in maintaining the old dialysate in said first zone at a temperature greater than the new dialysate in said second zone.

15

41. The method of claim 39, wherein said step of introducing comprises the step of heating up to two liters of new dialysate to said second temperature and returning said heated dialysate to said top of said tank in a non-turbulent manner.

20 42. A method of operating a dialyzer in an extracorporeal circuit, said dialyzer comprising a membrane with a blood side in a blood circuit and a dialysate side in a dialysate circuit, comprising the steps of:

during hemodialysis of a patient

- 120 -

pumping a fluid for a brief period through said dialyzer membrane from the dialysate side of said membrane to the blood side of said membrane during dialysis at least once, thereby moving any buildup of blood products on the blood side of said membrane away from said membrane; and

5 pumping said blood products through said blood circuit away from said membrane with a blood pump;

 whereby the buildup of blood products at the blood side of said membrane are removed during dialysis, enhancing the dialysis of the patient's blood and prolonging the life of said dialyzer.

10

43. The method of claim 42, wherein said step of pumping a fluid is performed at periodic intervals during dialysis.

15

44. The method of claim 43, wherein said brief periods comprise periods of between 15 and 30 seconds.

45. The method of claim 42, wherein said fluid comprises a dialysate solution.

46. The method of claim 42, wherein said fluid comprises a saline solution.

20

47. A method of conducting dialysis, the method performed in a dialysis machine having a dialysate circuit and an extracorporeal circuit having arterial and venous lines, comprising the steps of:

- 121 -

pumping a priming fluid through said extracorporeal circuit;
connecting said patient to said arterial and venous lines of the extracorporeal circuit;
pumping said priming fluid from said extracorporeal circuit through said dialyzer to
said dialysate circuit; and

5 pumping blood from said patient through said extracorporeal circuit to said dialyzer
and returning said blood to said patient, thereby avoiding pumping of said priming fluid into
said patient.

48. The method of claim 47, wherein said priming fluid is pumped through said dialyzer
10 by a UF pump in forward direction and wherein said priming fluid is returned to an
ultrafiltration tank.

49. A method for automatically testing the integrity of a dialysate filter prior to the
15 initiation of dialysis, said method performed in a dialysis machine having said dialysate filter
placed in a dialysate circuit wherein dialysate is pumped from a dialysate preparation tank
through said dialysate filter to a dialyzer and back to said tank, said dialysate filter
comprising a membrane having a dialyzer side and a dialysate tank side, dialysate being
filtered through said filter from said dialysate tank side to said dialyzer side, the method
20 comprising the steps of:

substantially removing fluids which may be present from said dialyzer side of said
dialysate filter;

pumping air into said dialyzer side of said dialysate filter to pressurize said dialysate

- 122 -

filter; and

measuring the pressurization of said dialysate filter, and

if said dialysate filter pressurizes, measuring the rate of decay of said pressurization, said pressurization and rate of decay being indicative of the integrity of said membrane of
5 said dialysate filter.

50. The method of claim 49, further comprising the step of pressurizing said dialysate filter to a maximum pressure above which the pressure drops suddenly, and
correlating said maximum pressure to a pore size of said membrane.

10

51. The method of claim 49, wherein said dialysate circuit further comprises a line conducting dialysate from said dialysate filter to said dialyzer and a pressure sensor in said line;

15

and wherein said measurements of pressure and the rate of decay of said pressure are made by said pressure sensor.

20

52. The method of claim 51, wherein said dialysis machine further comprises a central processing unit which receives pressure data from said pressure sensor, and wherein said central processing unit activates an audio or visual alarm alerting the patient in the event that said dialysate filter fails to pressurize or said rate of decay of pressure is greater than a predetermined threshold limit.

53. The method of claim 51, wherein said dialysis machine further comprises an

- 123 -

ultrafiltration tank and an ultrafiltration pump, said ultrafiltration tank and ultrafiltration pump in fluid communication with said dialysate filter, and wherein said step of pumping air into said dialyzer side of said dialysate filter with air to pressurize said dialysate filter comprises the step of:

5 pumping air from said ultrafiltration tank through said line to said dialysate filter with said ultrafiltration pump.

54. A method for automatically testing the integrity of a dialyzer, said method performed in a dialysis machine having a dialyzer in an extracorporeal circuit, wherein blood
10 is pumped from a patient via an arterial line to said dialyzer and returned to said patient via a venous line, said dialyzer comprising a membrane having a blood side and a dialysate side, the method comprising the steps of:

 substantially removing fluids which may be present at said blood side of said membrane;

15 pumping air into said blood side of said membrane to pressurize said dialyzer;
 measuring the pressurization of said dialyzer; and

 if said dialyzer pressurizes, measuring the rate of decay of said pressurization, said pressurization and rate of decay indicative of the integrity of said membrane of said dialyzer.

20

55. The method of claim 54, wherein said measurements of pressure and the rate of decay of said pressure are made by a pressure sensor placed in either said arterial line or said venous line.

- 124 -

56. The method of claim 54, wherein said dialysis machine further comprises a central processing unit which receives pressure data from said pressure sensor, and wherein said central processing unit activates an audio or visual alarm alerting the patient in the event that said dialyzer fails to pressurize or said rate of decay of pressure is greater than a
5 predetermined threshold limit.

57. The method of claim 54, wherein said dialysis machine further comprises an ultrafiltration tank and a blood pump, and wherein said step of pumping air into said blood side of said dialyzer with air to pressurize said dialyzer comprises the steps of:

10 placing said ultrafiltration tank in fluid communication with said blood side of said dialyzer; and

pumping air from said ultrafiltration tank to said blood side of said dialyzer with said blood pump.

15 58. A method for approximating the sodium clearance a dialyzer, said dialyzer having a membrane with a dialysate side and a blood side, comprising the steps of:

circulating dialysate containing sodium ions through said dialysate side of said dialyzer;

20 continuously circulating water through said blood side of said dialyzer, said water being single passed through said blood side of said dialyzer;

measuring the conductivity of said dialysate in an initial condition;

measuring the conductivity of said dialysate after said dialysate has passed through said dialyzer;

- 125 -

calculating the clearance of said sodium ions by said dialyzer from said measurements of conductivity, said measurement of conductivity of said dialysate after passing through said dialyzer becoming substantially constant as said dialysate and purified water are circulated through said dialyzer, said sodium clearance corresponding to the urea clearance of said dialyzer.

5

59. The method of claim 58, wherein said purified water is heated to a temperature of approximately 37 degrees C prior to being circulated through said blood side of said dialyzer.

10

60. The method of claim 58, wherein said purified water is stored in an ultrafiltration tank and pumped from said ultrafiltration tank to said dialyzer during said measurements of conductivity.

15

61. The method of claim 58, wherein said clearance test is performed two times prior to conducting a patient's blood through said dialyzer during a dialysis session, thereby insuring accurate calculation of said clearance of said dialyzer.

20

62. The method of claim 58, further comprising the step of returning water circulated through said blood side of said dialyzer back to a dialysate tank.

63. Apparatus comprising:

a dialyzer and a blood tubing set, said blood tubing set and dialyzer installed in a

- 126 -

dialysis machine, and

means for cleaning in situ within said machine said blood tubing set and said dialyzer after conducting dialysis of a patient without exposing said blood tubing set and said dialyzer to airborne contaminants.

5

64. The apparatus of claim 63, wherein said means for cleaning cleans said blood tubing set and said dialyzer with a fluid circulated through said blood tubing set and said dialyzer, said means for cleaning comprising means for causing said fluid to flow in alternating directions repeatedly through said dialyzer and means for causing fluid to transfer across said dialyzer from a dialysate circuit into said extracorporeal circuit.

10

65. A method of cleaning a reusable extracorporeal circuit, said extracorporeal circuit installed in a dialysis machine having a dialysate circuit and a pump for pumping fluids through said dialysate circuit, said extracorporeal circuit comprising a dialyzer and a blood tubing set, the method comprising the steps of:

15

backflushing fluids from said dialysate circuit through said dialyzer into said extracorporeal circuit,

inducing cyclical fluid flow rate changes and directions of fluid flow in said blood tubing set and said dialyzer;

20

said backflushing and cyclical flow rate and direction changes cleaning blood products from the blood side said dialyzer;

and pumping fluids containing said blood products from said extracorporeal circuit.

66. The method of claim 65, wherein said fluid comprises filtered water.
67. The method of claim 65, wherein said fluid comprises a dialysate solution.
- 5 68. The method of claim 65, wherein said fluid is heated to a temperature of between 37 and 85 degrees C.
69. The method of claim 65, further comprising the steps of measuring the pressure and flow rate of fluids being transported across said dialyzer during said step of backflushing,
10 and determining from said measurements of pressure and rate of fluid flow the fiber blockage condition of said dialyzer.

AMENDED CLAIMS

[received by the International Bureau on 30 July 1996 (30.07.96);
original claims 5,6,8,12 and 17 amended; remaining claims unchanged (19 pages)]

5. A method of disinfection of a dialysis machine having a water treatment module, an
a dialysate circuit and an extracorporeal circuit having a dialyzer, an arterial blood line and
a venous blood line, said arterial and venous blood lines each having a first end thereof
connected to said dialyzer and a second end for connecting to a patient, comprising the steps
5 of:

placing said second ends of said arterial and venous lines into fluid communication
with a source of heated water within said machine, and

circulating water heated to a high level disinfection temperature below the boiling
point of said water through said water treatment module, extracorporeal circuit including said
10 arterial and venous lines and said dialyzer, and dialysate circuit for a sufficient time to
achieve a high level disinfection of said machine.

6. In a dialysis machine having a water treatment module, a dialysate circuit circulating
dialysate to a dialyzer, and an extracorporeal circuit including an arterial line and a venous
15 line for transporting body fluids from a patient to said dialyzer and back to the patient, a
method of disinfecting said water treatment module, dialysate circuit and an extracorporeal
circuit including the arterial and venous lines and the dialyzer against bacteriological
substances without the use of chemical cleaning agents, comprising the steps of:

filtering water in said water treatment module through a reverse osmosis filter;
20 heating said filtered water within said dialysis machine to a predetermined disinfection
temperature below the boiling point of said filtered water, thereby producing heated, filtered
water;

circulating said heated, filtered water through said water treatment module, dialysate

circuit and extracorporeal circuit including said arterial and venous lines and said dialyzer for a sufficient amount of time at or above said high level disinfection temperature to achieve high level disinfection of said water treatment module, dialysate circuit and extracorporeal circuit including said arterial and venous lines and said dialyzer.

5

7. The method of claim 6, further comprising the steps of:

monitoring the temperature of said heated, filtered water in each of said water treatment module, dialysate circuit and said extracorporeal circuit during the circulation of said heated, filtered water.

10

8. The method of claim 7, further comprising the step of activating an indicator on said machine in the event that said monitored temperature of said water drops below a predetermined threshold temperature anywhere in the flow path of said heated, filtered water.

15

9. The method of claim 8, wherein said step of circulating said heated water comprises the step of circulating heated water sequentially through different flow paths in said machine, and wherein the method further comprises the step of repeating said sequential circulation of heated water through said flow paths in the event that the temperature of said heated, filtered water being circulated in any of said water treatment module, dialysate circuit or

20

extracorporeal circuit during the circulation of said heated, filtered water falls to or below a predetermined threshold temperature.

10. The method of claim 5 or claim 6, wherein said machine prepares a batch of dialysate

in a tank from chemicals housed in one or more batch chemical vessels, and

wherein said step of circulating said heated water further comprising the step of circulating said heated water to at least a portion of said batch vessels, thereby disinfecting at least a portion of said batch vessel, said portion of said batch vessel disinfecting being the location of where said batch vessel is opened to release said chemicals into said tank, thereby insuring disinfection of the interface between said chemicals and said tank.

11. The method as claimed in one of claims 5, 6 or 10, wherein said high level disinfection temperature is at least about 80 degrees C.

10

12. Apparatus for establishing fluid connection between an extracorporeal circuit and a source of disinfection fluids, said extracorporeal circuit comprising a dialyzer, an arterial blood line having an arterial blood line connector at the end thereof having an exterior surface and a venous blood line having a venous blood line connector at the end thereof having an exterior surface, comprising:

15

a disinfection line for carrying disinfection fluids from said source of disinfection fluids to said extracorporeal circuit;

a disinfection manifold comprising a first port and a second port, said first port for receiving said arterial line connector, said second port for receiving said venous line connector;

20

said first and second ports constructed so as to provide a space around said exterior surfaces of said arterial and venous connectors when said arterial and venous connectors are received in said first and second ports of said disinfection manifold, respectively;

a return line establishing a fluid connection with said disinfection manifold and carrying disinfection fluids from said extracorporeal circuit;

whereby disinfection fluids passed into said disinfection manifold by said disinfection line are routed through said arterial and venous blood lines and out of said extracorporeal circuit via said return line, achieving disinfection of said arterial and venous lines and disinfection of said exterior surfaces of said arterial and venous line connectors.

13. The apparatus of claim 12, wherein said disinfection fluid comprises water heated to a predetermined high level disinfection temperature.

14. The apparatus of claim 12, wherein said disinfection manifold further comprises a third port receiving said disinfection line, wherein said third port is in fluid communication with at least one of said first and second ports.

15. The apparatus of claim 14, wherein said disinfection manifold comprises a fourth port in air communication with a line having an air pressure adjustment valve and a clamp, said fourth port in fluid isolation from said first, second and third ports.

16. The apparatus of claim 14, wherein said disinfection manifold comprises a fourth port in air communication with a line having an air pump, said fourth port in fluid isolation from said first, second and third ports.

17. Apparatus for directing disinfection fluids to and from an extracorporeal circuit, said

extracorporeal circuit comprising an arterial line having an arterial line connector at the end thereof and a venous line having a venous line connector at the end thereof, comprising:

first, second and third ports, said first and second ports adapted for receiving said arterial and venous lines, respectively, said first and second ports constructed so as to provide a space around said exterior surfaces of said arterial and venous connectors when said arterial and venous connectors are received in said first and second ports, respectively;

fluid passages establishing fluid connection between said first and second ports; and
said third port having means for receiving a disinfection line for containing a disinfection fluid;

said disinfection line in fluid communication with at least one of said first or said second port, the other of said first and second ports in fluid communication with a line for conveying disinfection fluid circulated through said arterial and venous lines out of said extracorporeal circuit.

18. The apparatus of claim 17, wherein said apparatus further comprises a fourth port and an air pressure adjustment line having an air pressure adjustment valve and a clamp in air communication with said fourth port, said fourth port in fluid isolation from said first, second and third ports.

19. Apparatus for supplying a batch of chemicals stored in first, second and third vessels to a dialysate tank, comprising:

a housing in communication with said tank;

a first port in said housing through which a first dialysate chemical passes from said

first vessel into said housing;

a second port in said housing through which a second dialysate chemical passes from said second batch vessel into said housing;

a third port in said housing adapted to receive said third vessel, said third vessel containing a substance selected from the group of substances consisting of dialysate chemicals, salts, nutritional supplements, medications, cleaning agents and disinfecting agents.

20. Batch dialysate preparation apparatus, comprising

a vessel storing a batch quantity of dialysate chemicals;

a dialysate preparation tank receiving said batch quantity of dialysate chemicals along with water to form a batch quantity of dialysate; and

means associated with said tank for automatically introducing said batch of chemicals from said vessel into said dialysate preparation tank.

21. The apparatus of claim 20, wherein said means associated with said tank further comprises means for receiving at least two vessels and means for automatically opening said two vessels, permitting said chemicals to be introduced into said tank.

22. Apparatus comprising:

a bottle containing a unit batch of chemicals for treatment of a medical condition, said bottle adapted to be installed in communication with a tank for delivery of said unit batch of chemicals automatically into said tank: and

a machine-readable indicator containing coded information as to the contents of said bottle, said machine-readable indicator applied to said bottle in a manner for permitting machine identification of the contents of said bottle,

whereby machine identification of the contents of said bottle occurs prior to introduction of said chemicals into said tank.

23. The apparatus of claim 22, wherein said unit batch of chemicals comprises chemicals for treating renal failure.

24. The apparatus of claim 22, wherein said tank comprises a dialysate preparation tank and said bottle is mounted to a chemical applicator prior to release of said chemicals into said dialysate preparation tank, and wherein said machine-readable indicator comprises a touch button applied to said exterior surface of said bottle, said touch button positioned on the exterior surface of said bottle such that when said bottle is mounted to said chemical applicator, said touch button is placed in touching contact with a reader for said touch button.

25. The apparatus of claim 24, wherein said bottle further comprises a semicircular rim and a retaining bead securely retaining said touch button to said exterior surface of said bottle.

26. The apparatus of claim 22, wherein said bottle comprises a polypropylene cap engageable with a bottle shell, wherein said bottle shell is made from polyethylene, and

wherein said cap further comprises a threaded region applied to the exterior of said cap for mounting said bottle to said chemical applicator.

27. The apparatus of claim 22, wherein said machine-readable indicator comprises a bar code applied to the exterior surface of said bottle, said bar code positioned such that when said bottle is mounted to a chemical applicator, said bar code is oriented in alignment with a reader for said bar code.

28. The apparatus of claim 22, wherein said machine-readable indicator comprises a magnetic strip applied to said exterior surface of said bottle, said magnetic strip positioned such that when said bottle is mounted to a chemical applicator, said magnetic strip is oriented in alignment with a reader for said magnetic strip.

29. The apparatus of claim 22, wherein said machine-readable indicator comprises a two or three dimensional matrix containing coded information.

30. The apparatus of claim 22, wherein said machine-readable indicator comprises a radio-frequency transmitter, said radio-frequency transmitter storing coded information as to the chemicals in said vessel.

31. The apparatus of claim 22, wherein said unit batch of chemicals comprises a dialysate chemical.

32. The apparatus of claim 22, wherein said unit batch of chemicals comprises a cleaning or disinfecting agent.

33. The apparatus of claim 22, wherein said vessel further comprises a seal made from polypropylene.

34. The apparatus of claim 22, further comprising means for automatically removing said touch button from said bottle during removal of said bottle from said chemical applicator.

35. A chemical application system for applying chemicals into a dialysis tank comprising:
at least one bottle containing dialysate chemicals and having an exterior surface with a removable machine-readable indicator affixed thereto;

a chemical applicator in communication with said tank, said chemical applicator including a spike movable between upper and lower positions;

said chemical applicator further comprising means for mounting said bottle to said chemical applicator;

means for removing said removable indicator from said bottle.

36. The system of claim 35, further comprising catchment means for catching and collecting said removed machine-readable indicator.

37. The apparatus of claim 35, wherein said removable machine-readable indicator comprises a touch button.

38. In a dialysis system comprising a chemical applicator for introducing dialysate chemicals into a dialysate preparation tank, a method for automatically identifying the contents of a vessel containing batch dialysate chemicals prior to the introduction of said chemicals to said tank, comprising the steps of:

applying a machine-readable indicator to said vessel, said indicator containing coded information as to the contents of the chemicals within said vessel;

mounting said vessel to said chemical applicator such that said machine-readable indicator is positioned in a location for reading said indicator;

reading the indicator and decoding said information as to the contents of the bottle;

comparing said decoded information with stored information as to the proper dialysate chemicals for the patient;

alerting the patient if the vessel contains improper dialysate chemicals, thereby allowing the user to replace said vessel with a vessel containing proper chemicals; and,

after a vessel containing proper chemicals has been mounted to said chemical applicator,

introducing the chemicals into said tank.

39. A method for maintaining separation of old and new dialysate in a batch dialysate preparation tank, comprising the steps of:

storing said new dialysate in said tank at a first temperature;

withdrawing said new dialysate from the bottom of said tank;

returning old dialysate to said tank at the top of said tank at a second temperature warmer than said first temperature in a manner so as to substantially prevent turbulence of

said old dialysate during the return of said old dialysate to said tank;

introducing dialysate into said top of said tank at a temperature greater than said first temperature prior to the return of said old dialysate to said tank, thereby establishing a temperature gradient of dialysate in said tank with said warmer introduced dialysate forming said first zone at the top of said tank, said old dialysate being returned to said tank and mixing with said introduced warmer dialysate in said first zone;

the temperature differential between the first and second temperatures of dialysate causing old and new dialysate to be maintained in substantially discrete zones with said old dialysate in a first zone above the new dialysate in a second zone with a boundary therebetween, said boundary lowering as dialysis of the patient proceeds.

40. The method of claim 39, wherein said tank is provided with heating elements in the upper region of said tank, said heating elements assisting in maintaining the old dialysate in said first zone at a temperature greater than the new dialysate in said second zone.

41. The method of claim 39, wherein said step of introducing comprises the step of heating up to two liters of new dialysate to said second temperature and returning said heated dialysate to said top of said tank in a non-turbulent manner.

42. A method of operating a dialyzer in an extracorporeal circuit, said dialyzer comprising a membrane with a blood side in a blood circuit and a dialysate side in a dialysate circuit, comprising the steps of:

during hemodialysis of a patient

pumping a fluid for a brief period through said dialyzer membrane from the dialysate side of said membrane to the blood side of said membrane during dialysis at least once, thereby moving any buildup of blood products on the blood side of said membrane away from said membrane; and

pumping said blood products through said blood circuit away from said membrane with a blood pump;

whereby the buildup of blood products at the blood side of said membrane are removed during dialysis, enhancing the dialysis of the patient's blood and prolonging the life of said dialyzer.

43. The method of claim 42, wherein said step of pumping a fluid is performed at periodic intervals during dialysis.

44. The method of claim 43, wherein said brief periods comprise periods of between 15 and 30 seconds.

45. The method of claim 42, wherein said fluid comprises a dialysate solution.

46. The method of claim 42, wherein said fluid comprises a saline solution.

47. A method of conducting dialysis, the method performed in a dialysis machine having a dialysate circuit and an extracorporeal circuit having arterial and venous lines, comprising the steps of:

- 140 -

pumping a priming fluid through said extracorporeal circuit;
connecting said patient to said arterial and venous lines of the extracorporeal circuit;
pumping said priming fluid from said extracorporeal circuit through said dialyzer to
said dialysate circuit; and

pumping blood from said patient through said extracorporeal circuit to said dialyzer
and returning said blood to said patient, thereby avoiding pumping of said priming fluid into
said patient.

48. The method of claim 47, wherein said priming fluid is pumped through said dialyzer
by a UF pump in forward direction and wherein said priming fluid is returned to an
ultrafiltration tank.

49. A method for automatically testing the integrity of a dialysate filter prior to the
initiation of dialysis, said method performed in a dialysis machine having said dialysate filter
placed in a dialysate circuit wherein dialysate is pumped from a dialysate preparation tank
through said dialysate filter to a dialyzer and back to said tank, said dialysate filter
comprising a membrane having a dialyzer side and a dialysate tank side, dialysate being
filtered through said filter from said dialysate tank side to said dialyzer side, the method
comprising the steps of:

substantially removing fluids which may be present from said dialyzer side of said
dialysate filter;

pumping air into said dialyzer side of said dialysate filter to pressurize said dialysate

filter; and

measuring the pressurization of said dialysate filter, and

if said dialysate filter pressurizes, measuring the rate of decay of said pressurization, said pressurization and rate of decay being indicative of the integrity of said membrane of said dialysate filter.

50. The method of claim 49, further comprising the step of pressurizing said dialysate filter to a maximum pressure above which the pressure drops suddenly, and correlating said maximum pressure to a pore size of said membrane.

51. The method of claim 49, wherein said dialysate circuit further comprises a line conducting dialysate from said dialysate filter to said dialyzer and a pressure sensor in said line;

and wherein said measurements of pressure and the rate of decay of said pressure are made by said pressure sensor.

52. The method of claim 51, wherein said dialysis machine further comprises a central processing unit which receives pressure data from said pressure sensor, and wherein said central processing unit activates an audio or visual alarm alerting the patient in the event that said dialysate filter fails to pressurize or said rate of decay of pressure is greater than a predetermined threshold limit.

53. The method of claim 51, wherein said dialysis machine further comprises an

ultrafiltration tank and an ultrafiltration pump, said ultrafiltration tank and ultrafiltration pump in fluid communication with said dialysate filter, and wherein said step of pumping air into said dialyzer side of said dialysate filter with air to pressurize said dialysate filter comprises the step of:

pumping air from said ultrafiltration tank through said line to said dialysate filter with said ultrafiltration pump.

54. A method for automatically testing the integrity of a dialyzer, said method performed in a dialysis machine having a dialyzer in an extracorporeal circuit, wherein blood is pumped from a patient via an arterial line to said dialyzer and returned to said patient via a venous line, said dialyzer comprising a membrane having a blood side and a dialysate side, the method comprising the steps of:

substantially removing fluids which may be present at said blood side of said membrane;

pumping air into said blood side of said membrane to pressurize said dialyzer;

measuring the pressurization of said dialyzer; and

if said dialyzer pressurizes, measuring the rate of decay of said pressurization, said pressurization and rate of decay indicative of the integrity of said membrane of said dialyzer.

55. The method of claim 54, wherein said measurements of pressure and the rate of decay of said pressure are made by a pressure sensor placed in either said arterial line or said venous line.

56. The method of claim 54, wherein said dialysis machine further comprises a central processing unit which receives pressure data from said pressure sensor, and wherein said central processing unit activates an audio or visual alarm alerting the patient in the event that said dialyzer fails to pressurize or said rate of decay of pressure is greater than a predetermined threshold limit.

57. The method of claim 54, wherein said dialysis machine further comprises an ultrafiltration tank and a blood pump, and wherein said step of pumping air into said blood side of said dialyzer with air to pressurize said dialyzer comprises the steps of:

placing said ultrafiltration tank in fluid communication with said blood side of said dialyzer; and

pumping air from said ultrafiltration tank to said blood side of said dialyzer with said blood pump.

58. A method for approximating the sodium clearance a dialyzer, said dialyzer having a membrane with a dialysate side and a blood side, comprising the steps of:

circulating dialysate containing sodium ions through said dialysate side of said dialyzer;

continuously circulating water through said blood side of said dialyzer, said water being single passed through said blood side of said dialyzer;

measuring the conductivity of said dialysate in an initial condition;

measuring the conductivity of said dialysate after said dialysate has passed through said dialyzer;

calculating the clearance of said sodium ions by said dialyzer from said measurements of conductivity, said measurement of conductivity of said dialysate after passing through said dialyzer becoming substantially constant as said dialysate and purified water are circulated through said dialyzer, said sodium clearance corresponding to the urea clearance of said dialyzer.

59. The method of claim 58, wherein said purified water is heated to a temperature of approximately 37 degrees C prior to being circulated through said blood side of said dialyzer.

60. The method of claim 58, wherein said purified water is stored in an ultrafiltration tank and pumped from said ultrafiltration tank to said dialyzer during said measurements of conductivity.

61. The method of claim 58, wherein said clearance test is performed two times prior to conducting a patient's blood through said dialyzer during a dialysis session, thereby insuring accurate calculation of said clearance of said dialyzer.

62. The method of claim 58, further comprising the step of returning water circulated through said blood side of said dialyzer back to a dialysate tank.

63. Apparatus comprising:
a dialyzer and a blood tubing set, said blood tubing set and dialyzer installed in a

dialysis machine, and

means for cleaning in situ within said machine said blood tubing set and said dialyzer after conducting dialysis of a patient without exposing said blood tubing set and said dialyzer to airborne contaminants.

64. The apparatus of claim 63, wherein said means for cleaning cleans said blood tubing set and said dialyzer with a fluid circulated through said blood tubing set and said dialyzer, said means for cleaning comprising means for causing said fluid to flow in alternating directions repeatedly through said dialyzer and means for causing fluid to transfer across said dialyzer from a dialysate circuit into said extracorporeal circuit.

65. A method of cleaning a reusable extracorporeal circuit, said extracorporeal circuit installed in a dialysis machine having a dialysate circuit and a pump for pumping fluids through said dialysate circuit, said extracorporeal circuit comprising a dialyzer and a blood tubing set, the method comprising the steps of:

backflushing fluids from said dialysate circuit through said dialyzer into said extracorporeal circuit,

inducing cyclical fluid flow rate changes and directions of fluid flow in said blood tubing set and said dialyzer;

said backflushing and cyclical flow rate and direction changes cleaning blood products from the blood side said dialyzer;

and pumping fluids containing said blood products from said extracorporeal circuit.

66. The method of claim 65, wherein said fluid comprises filtered water.
67. The method of claim 65, wherein said fluid comprises a dialysate solution.
68. The method of claim 65, wherein said fluid is heated to a temperature of between 37 and 85 degrees C.
69. The method of claim 65, further comprising the steps of measuring the pressure and flow rate of fluids being transported across said dialyzer during said step of backflushing, and determining from said measurements of pressure and rate of fluid flow the fiber blockage condition of said dialyzer.

FIG. 1

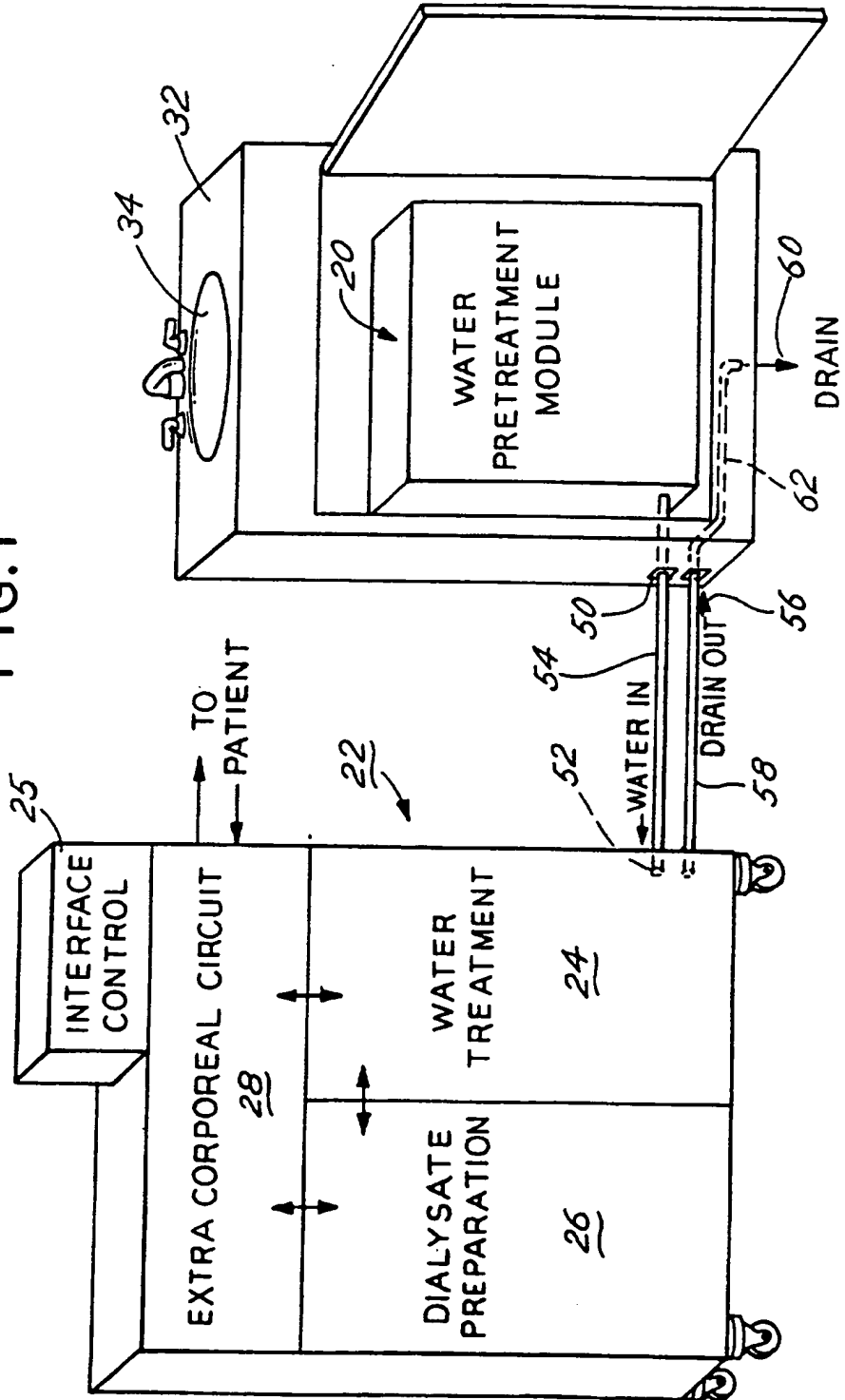

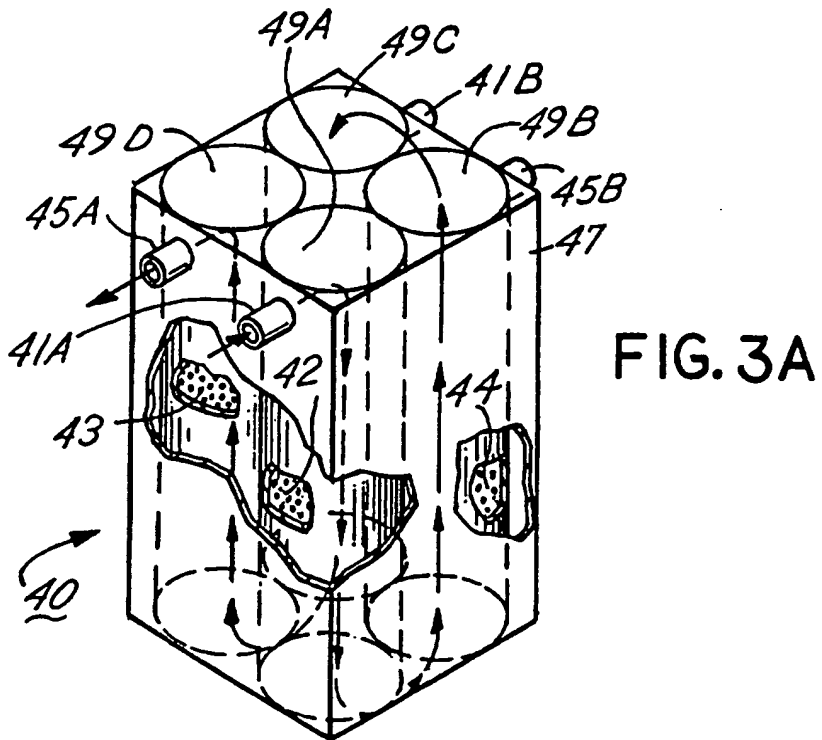
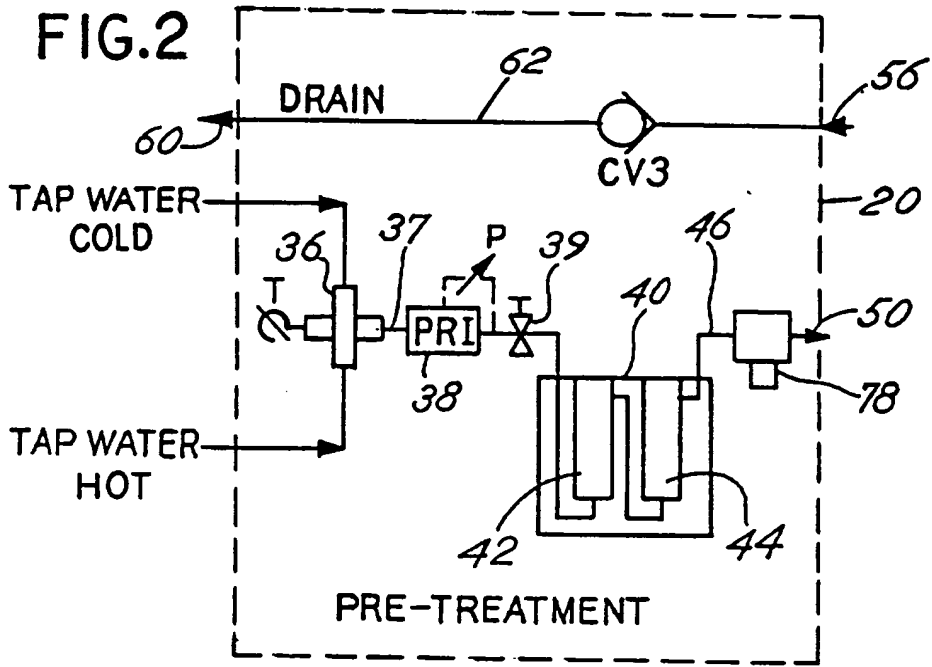

FIG. 3B

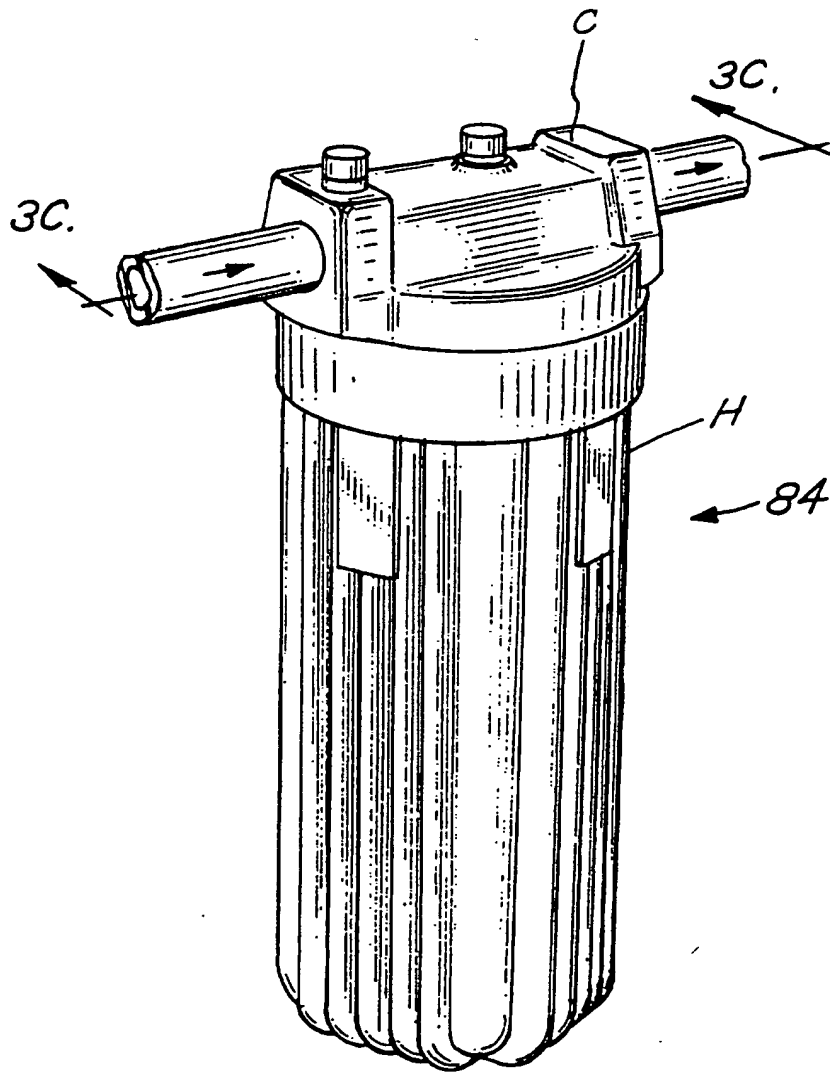
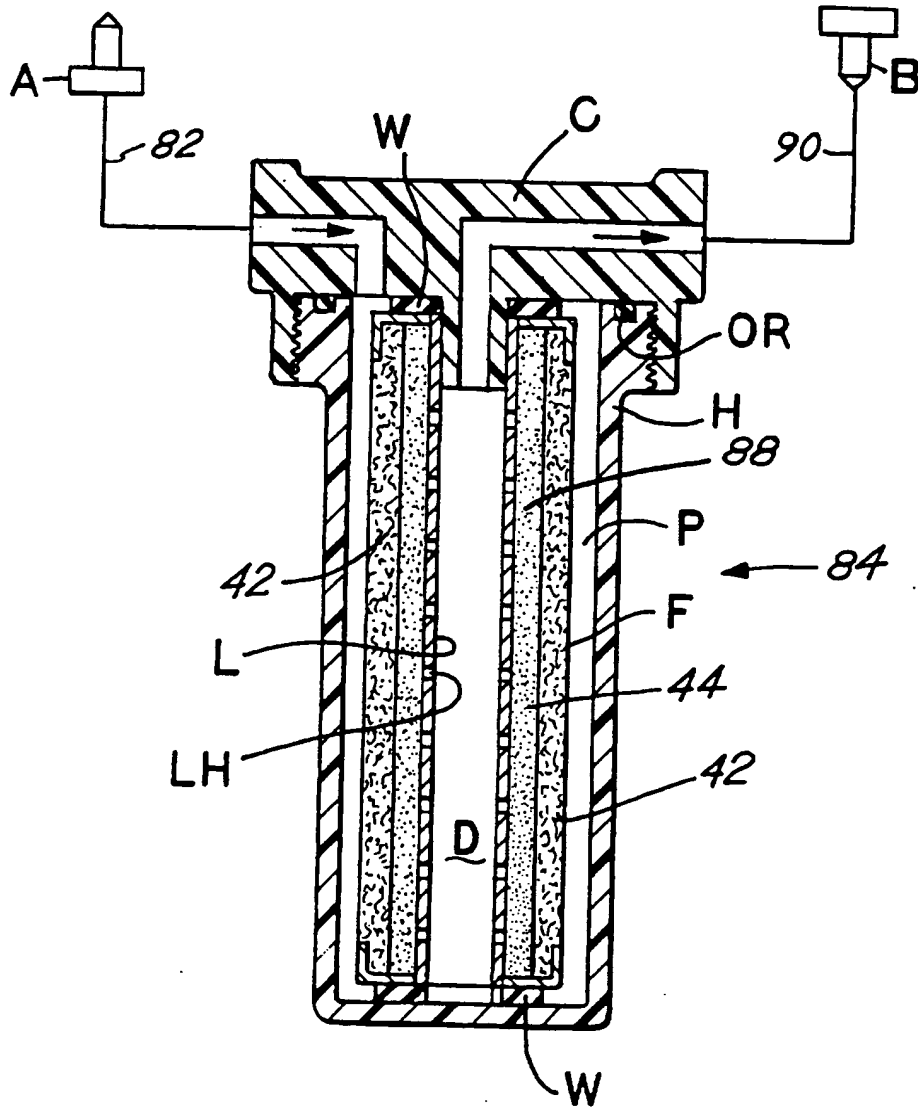

FIG. 3C



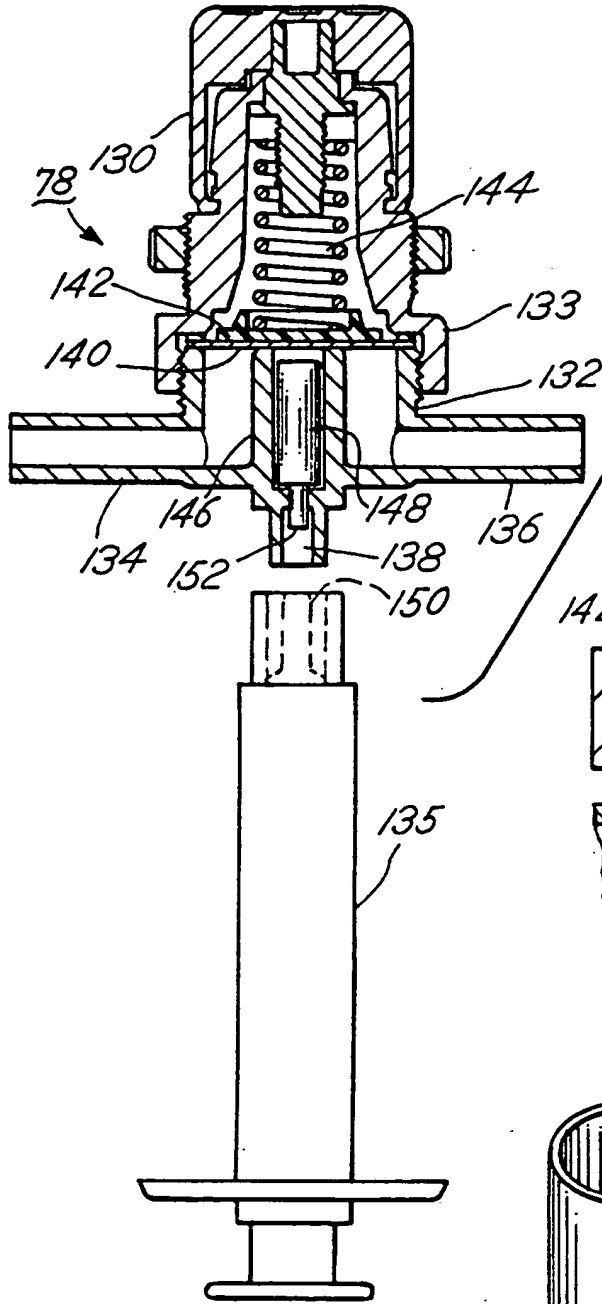

Fig. 4A

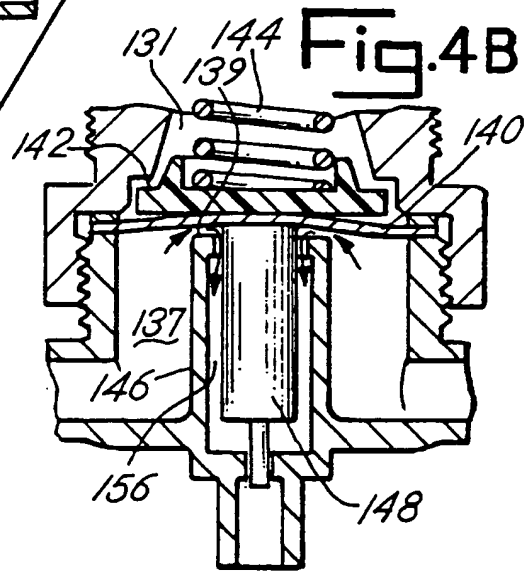

Fig. 4B

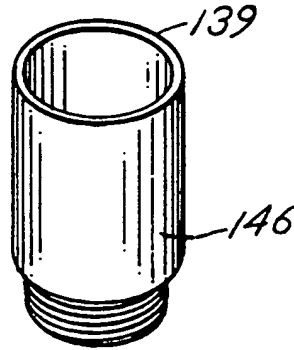

Fig. 4C

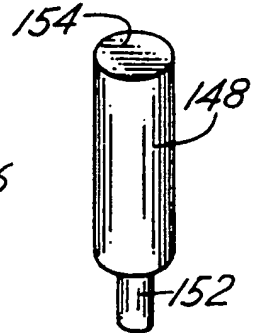

Fig. 4D

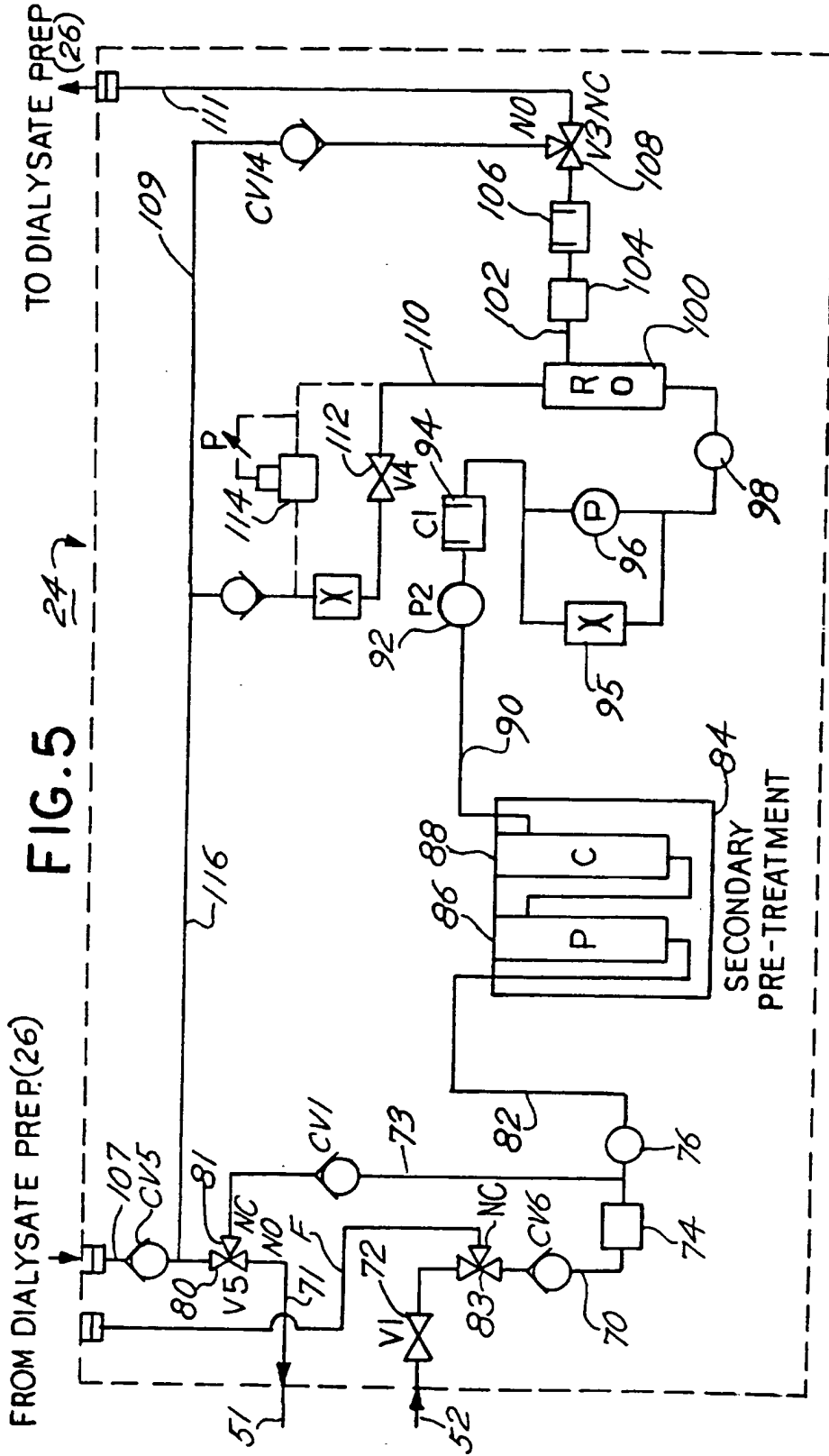

FIG. 5

24

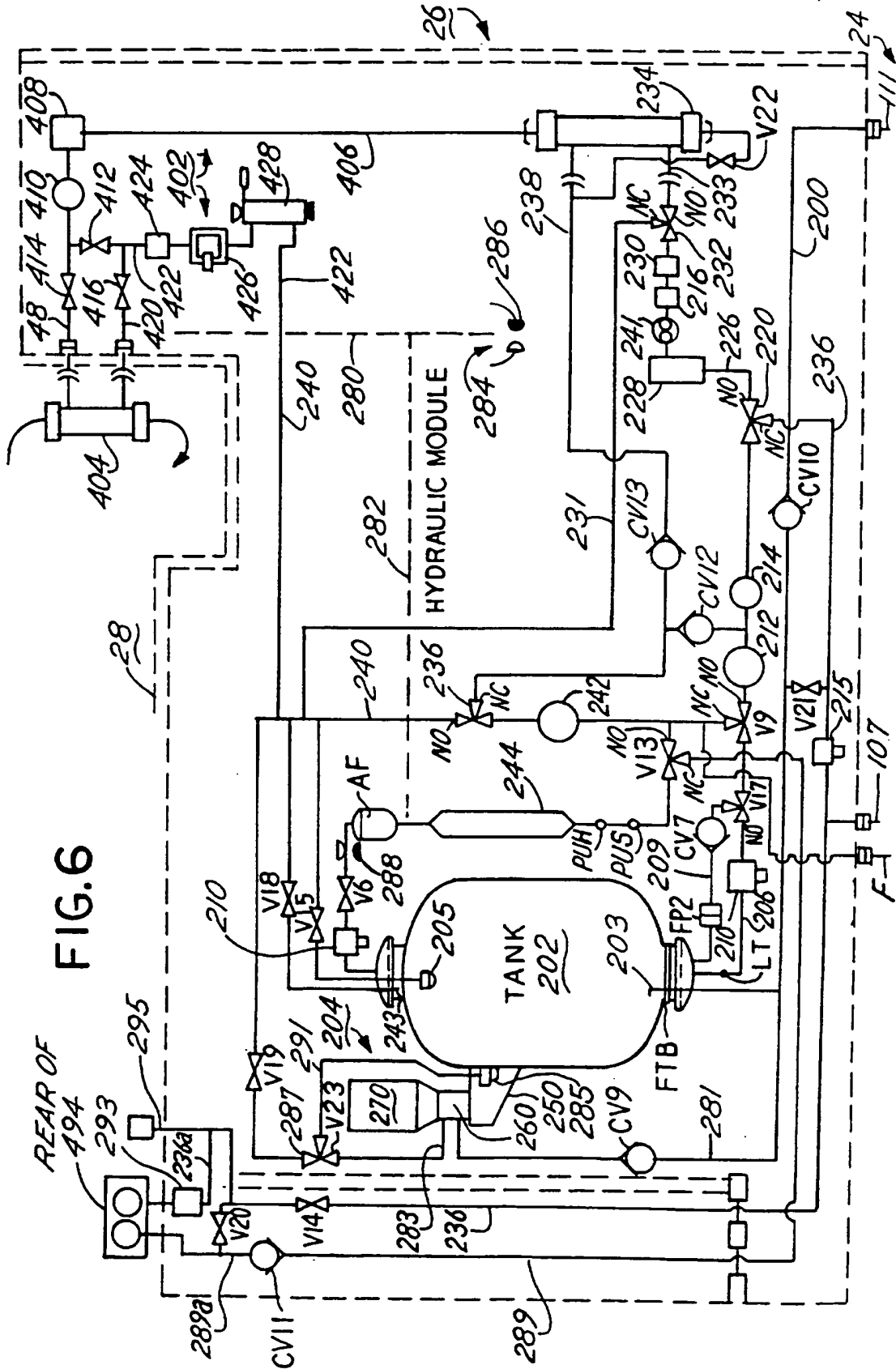
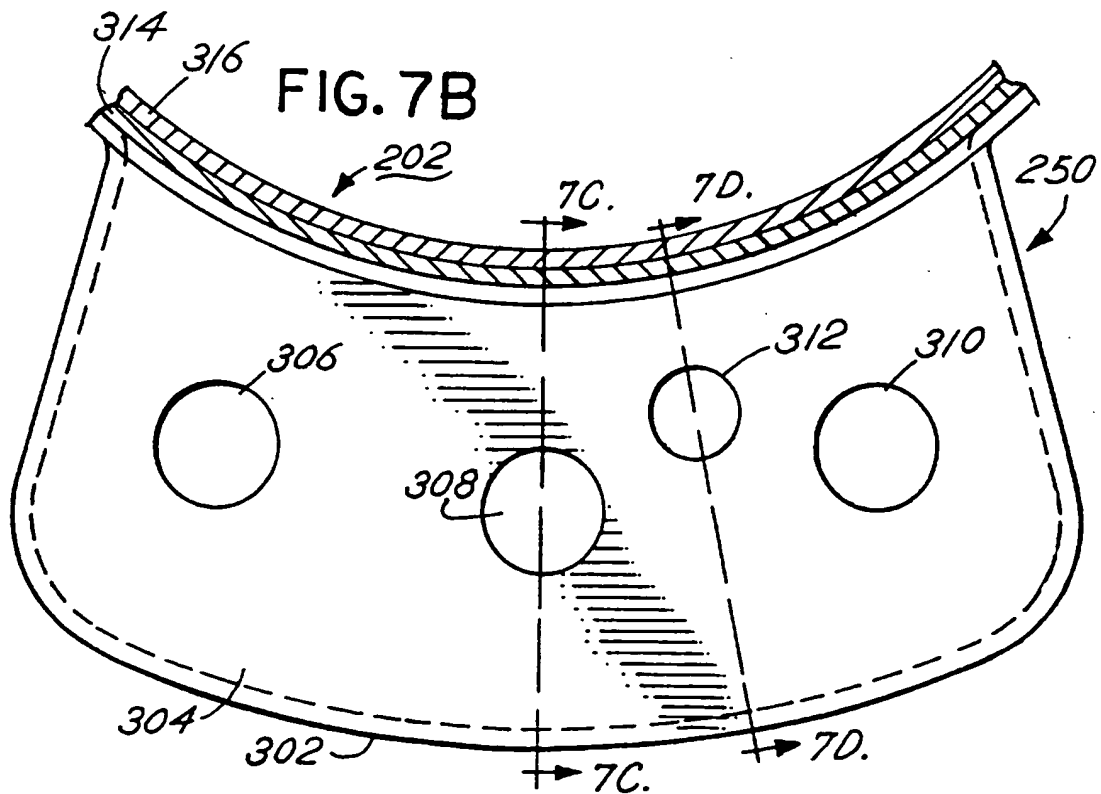
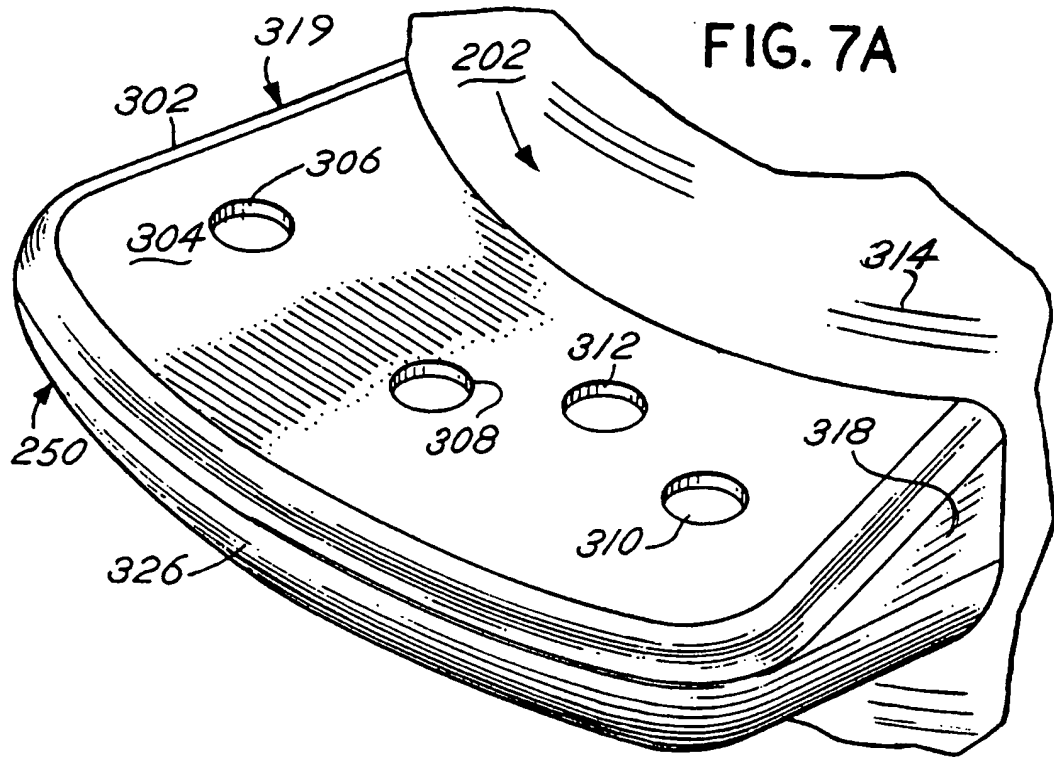

FIG. 6



9/47

FIG. 7C

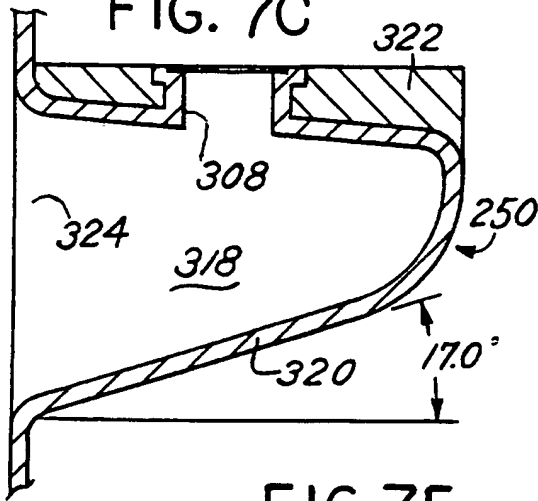

FIG. 7D

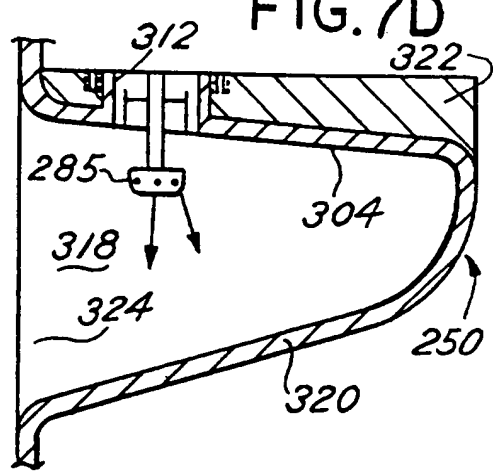

FIG. 7E

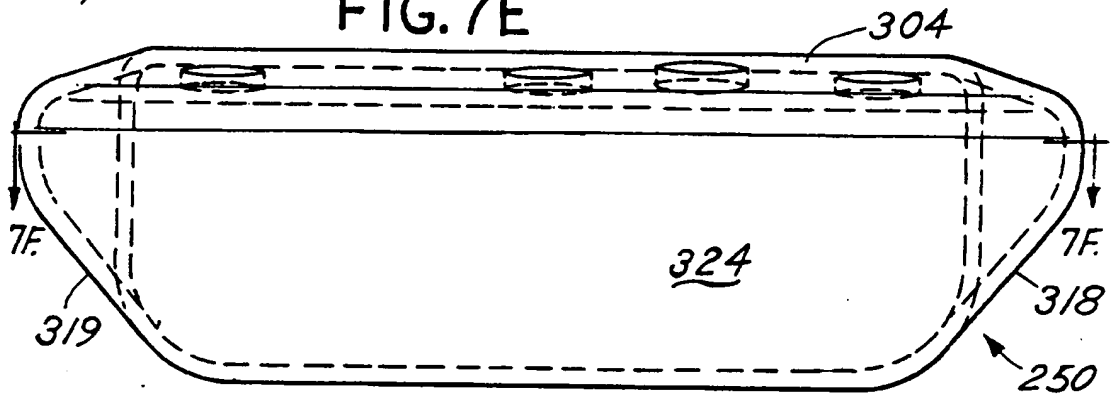
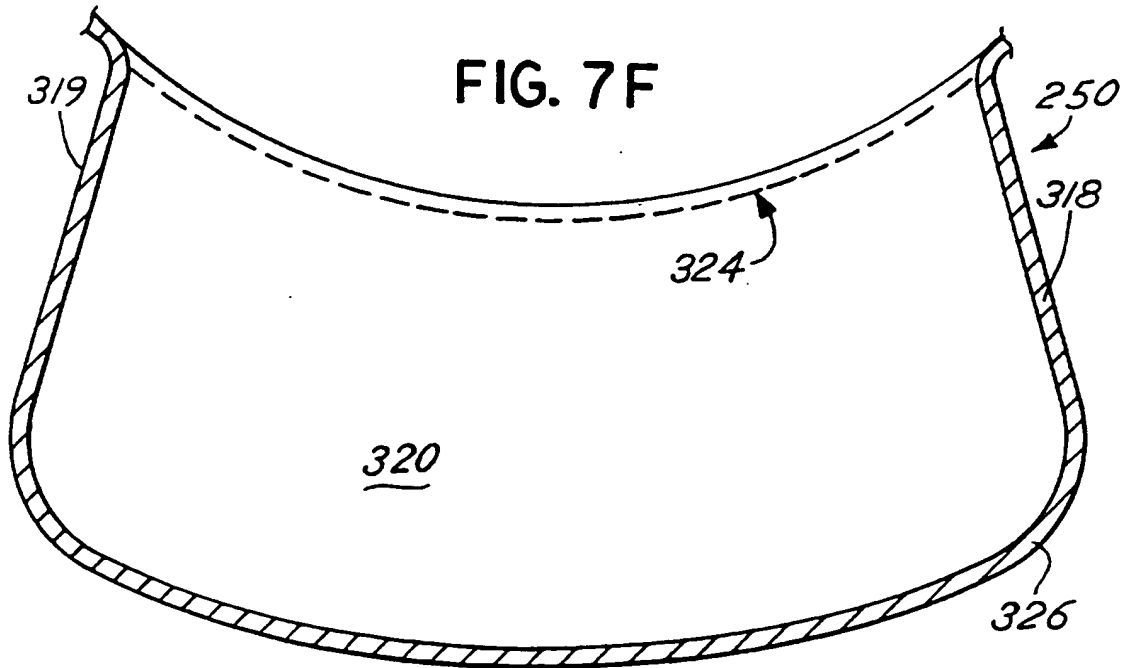
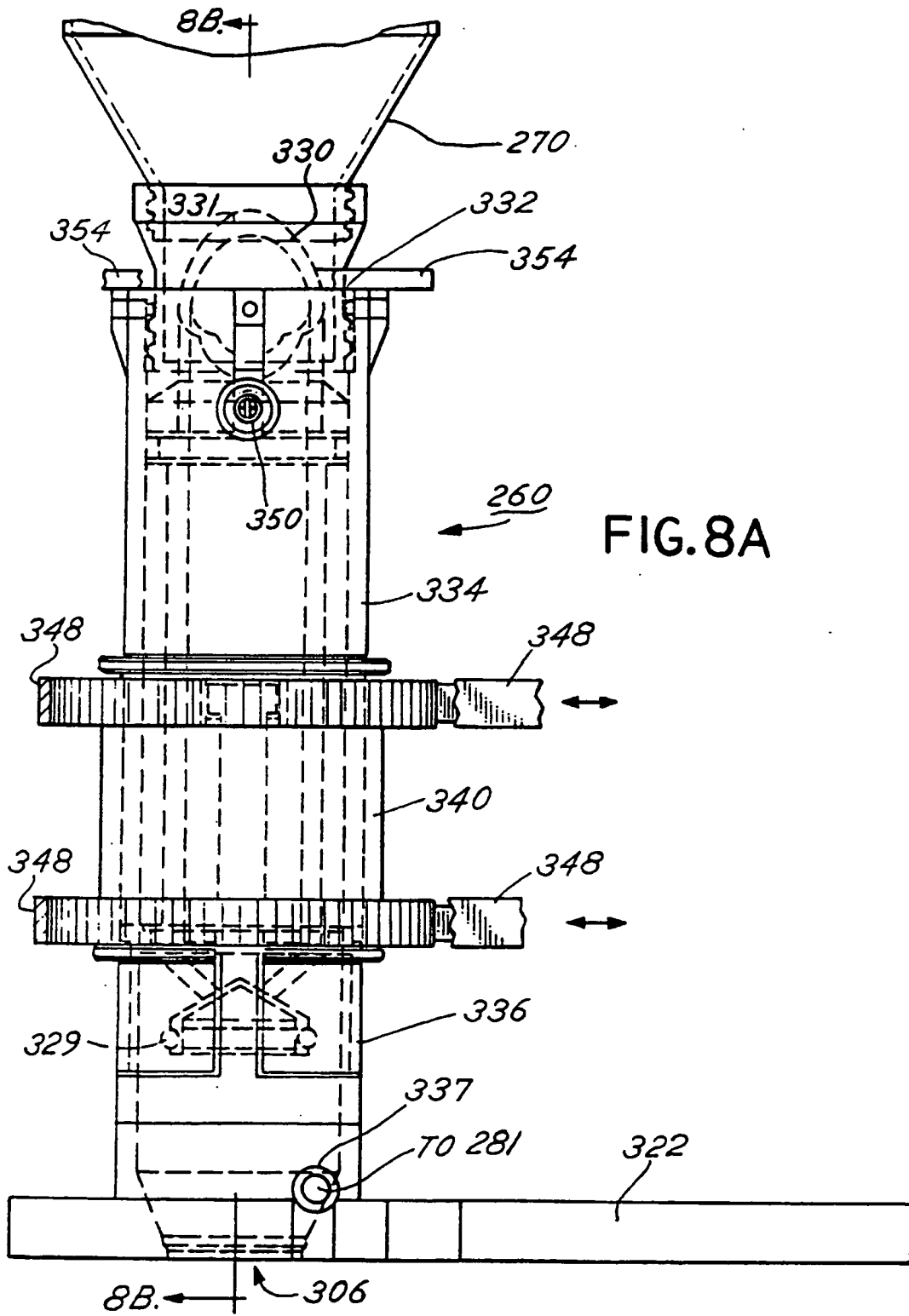

FIG. 7F



10/47



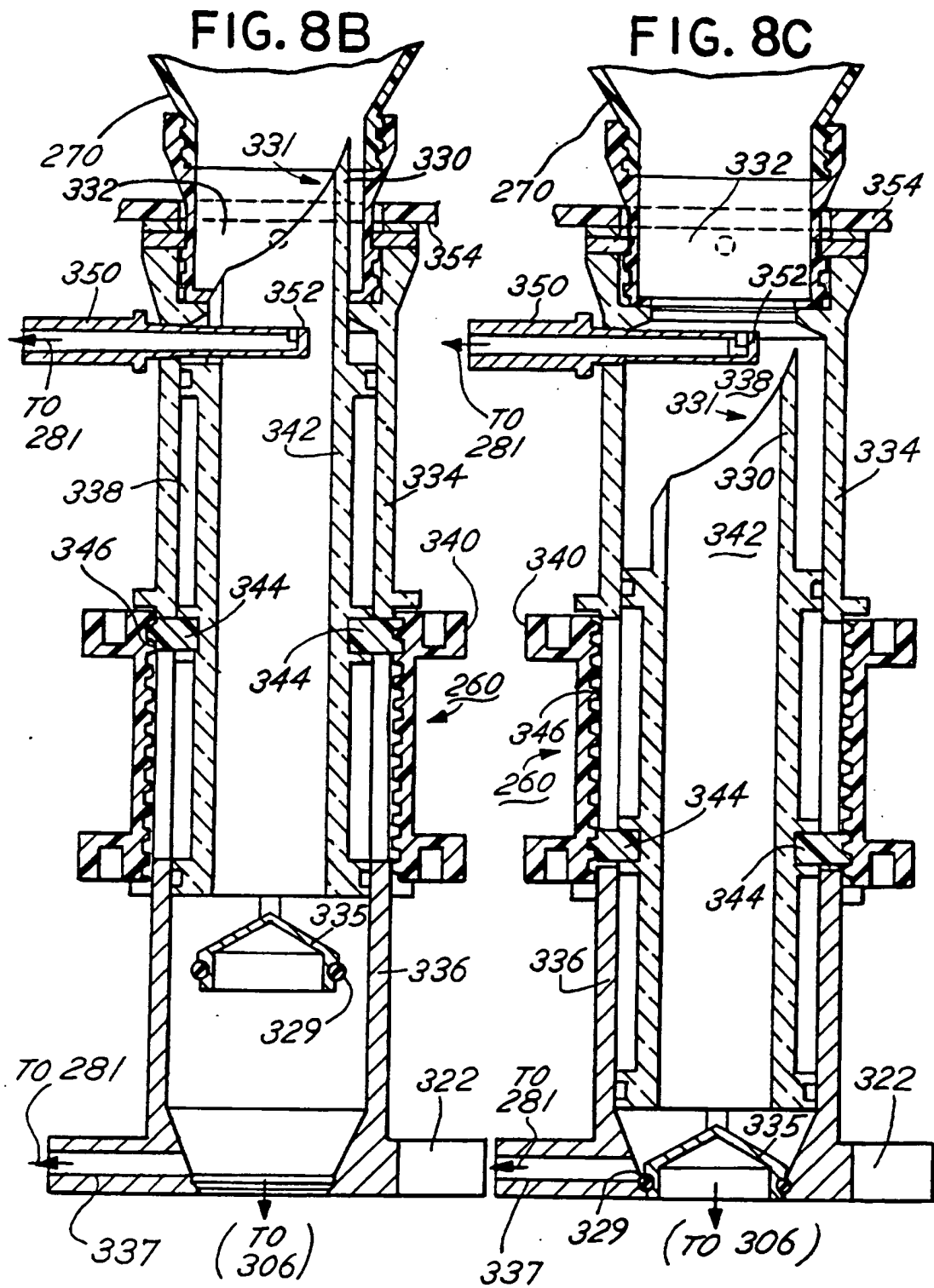

FIG. 9A

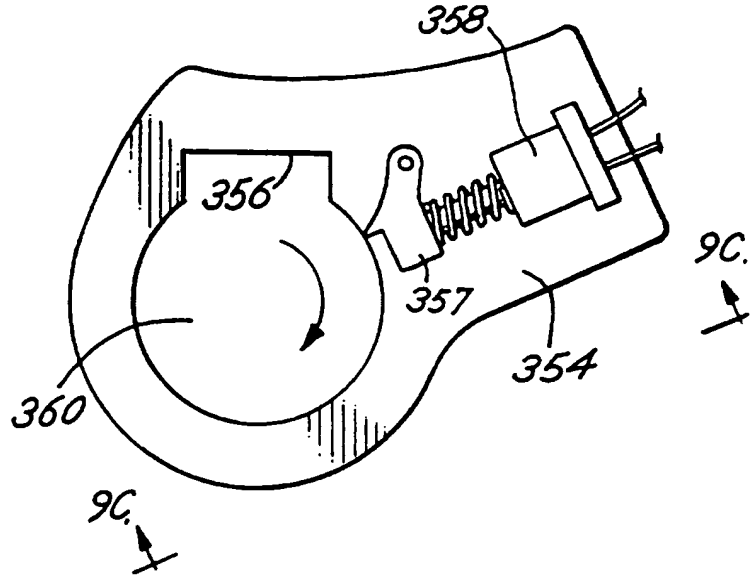

FIG. 9B

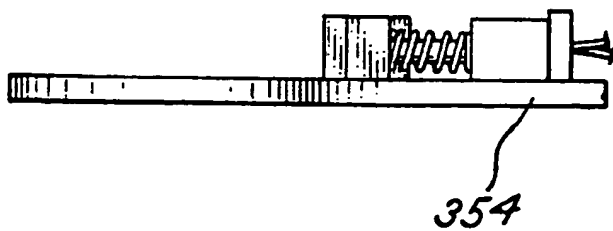
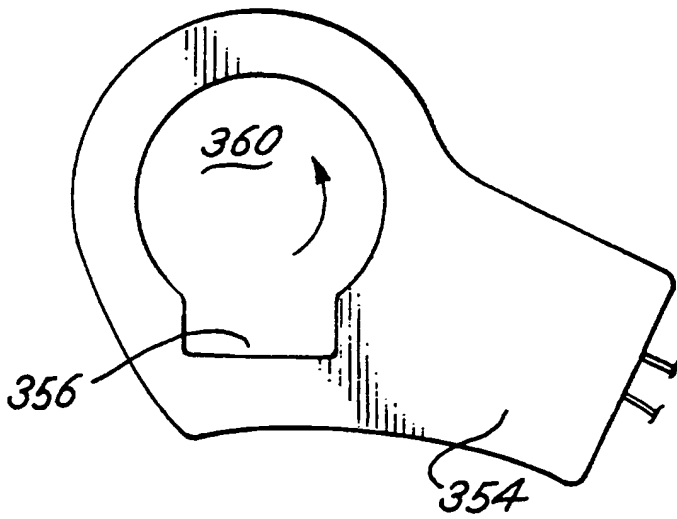

FIG. 9C

FIG.10A

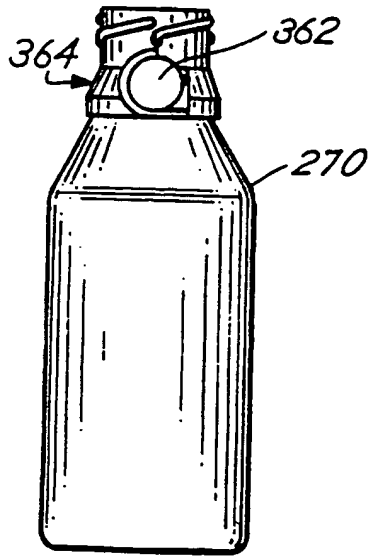

FIG.10B

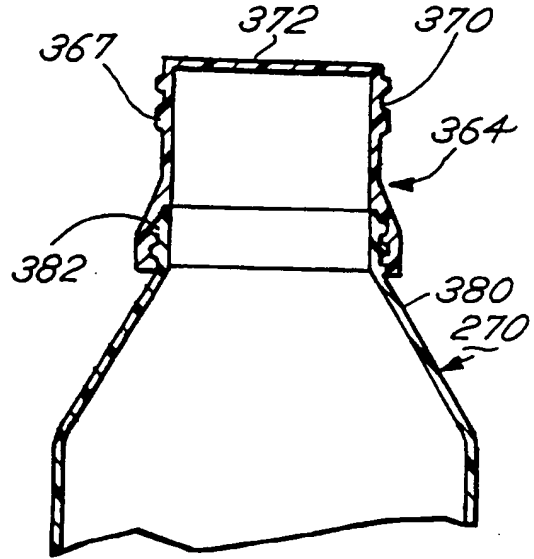

FIG.10C

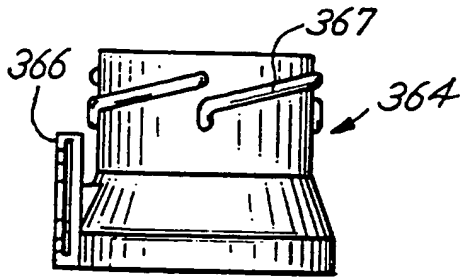

FIG.10D

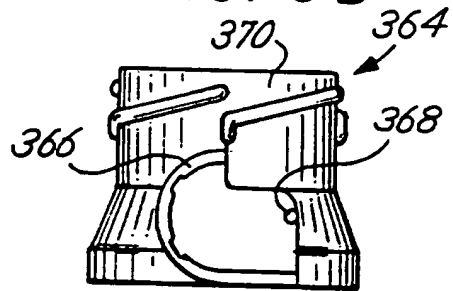

FIG.10E

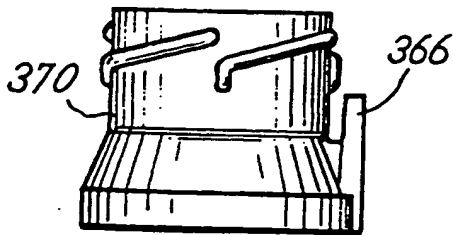

FIG.10F

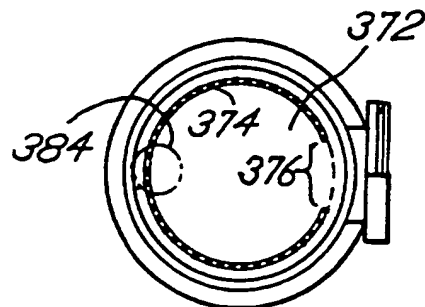

FIG. IIA

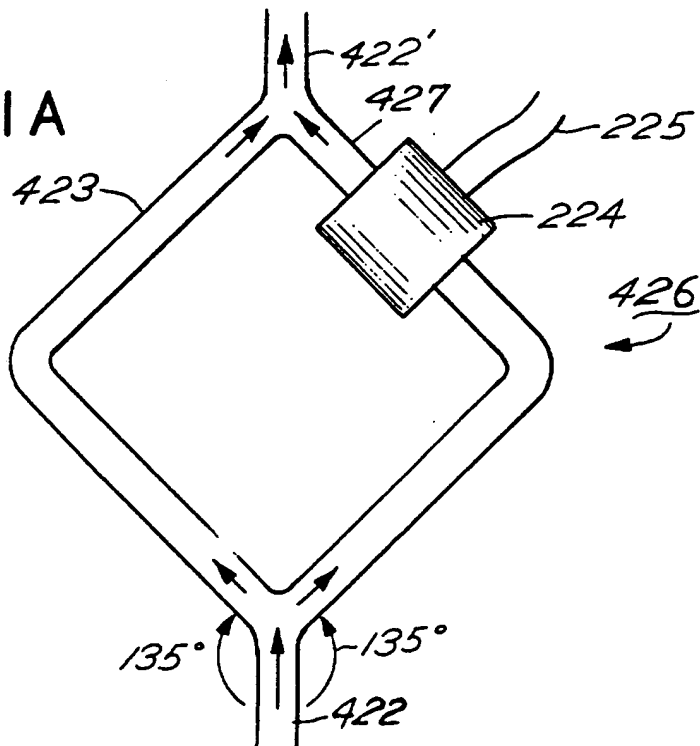
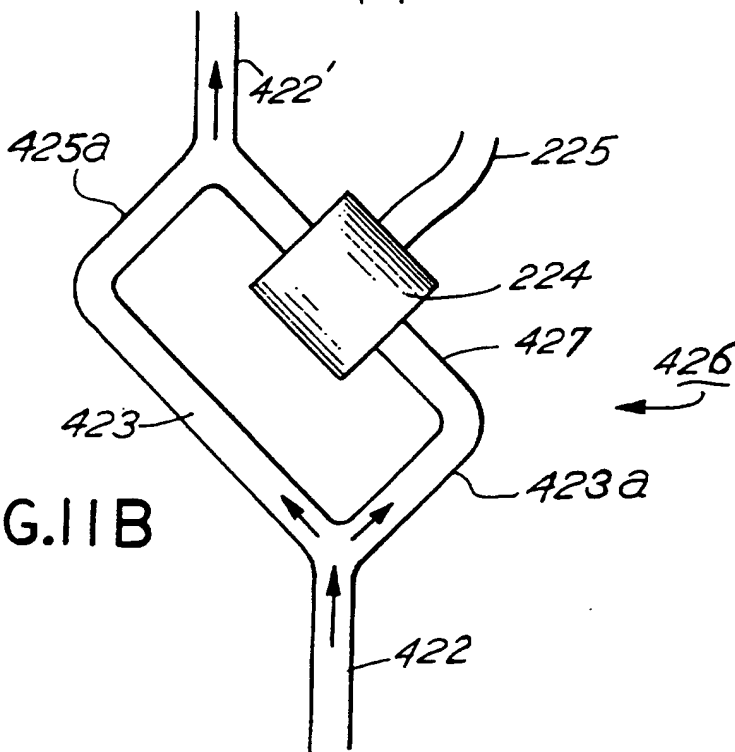

FIG. IIB



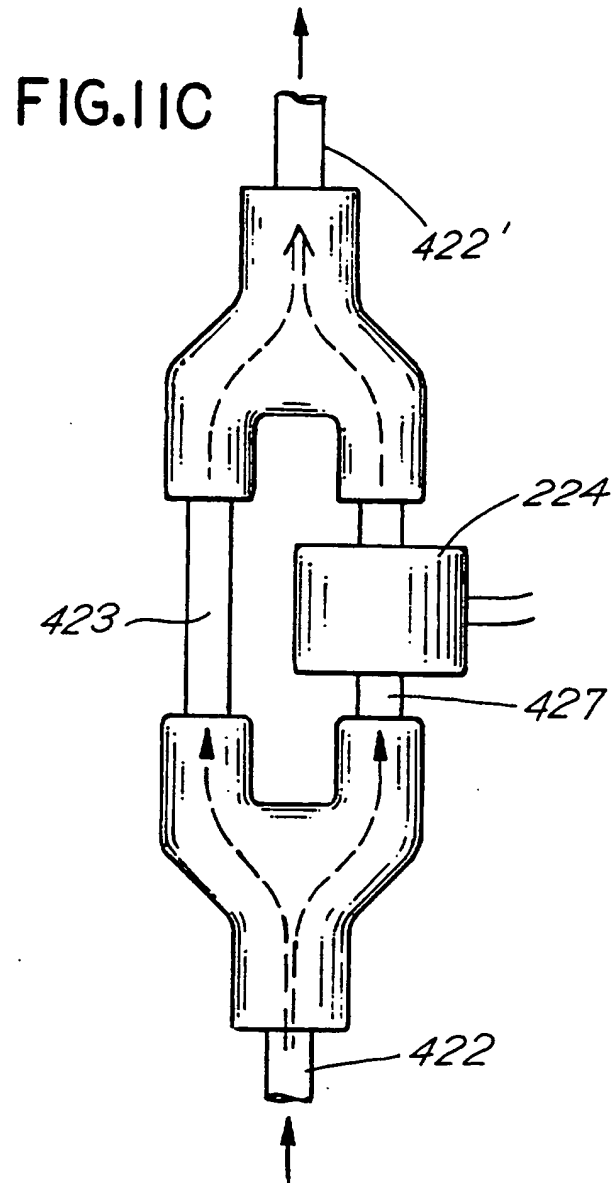

FIG. 12

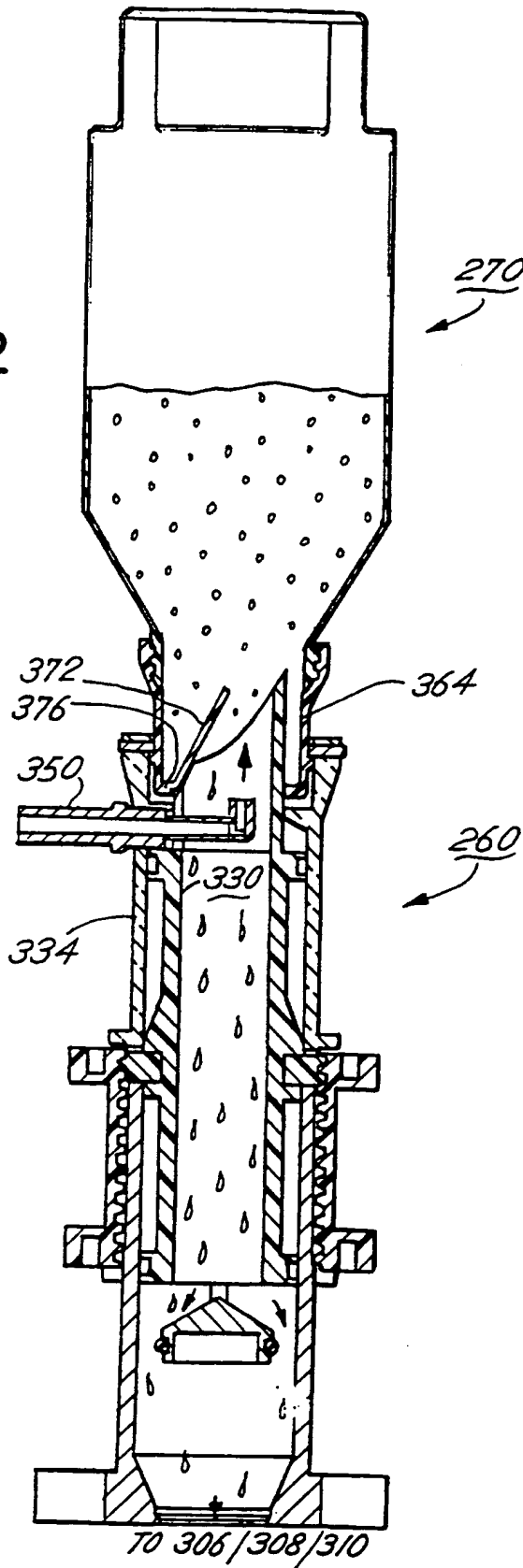
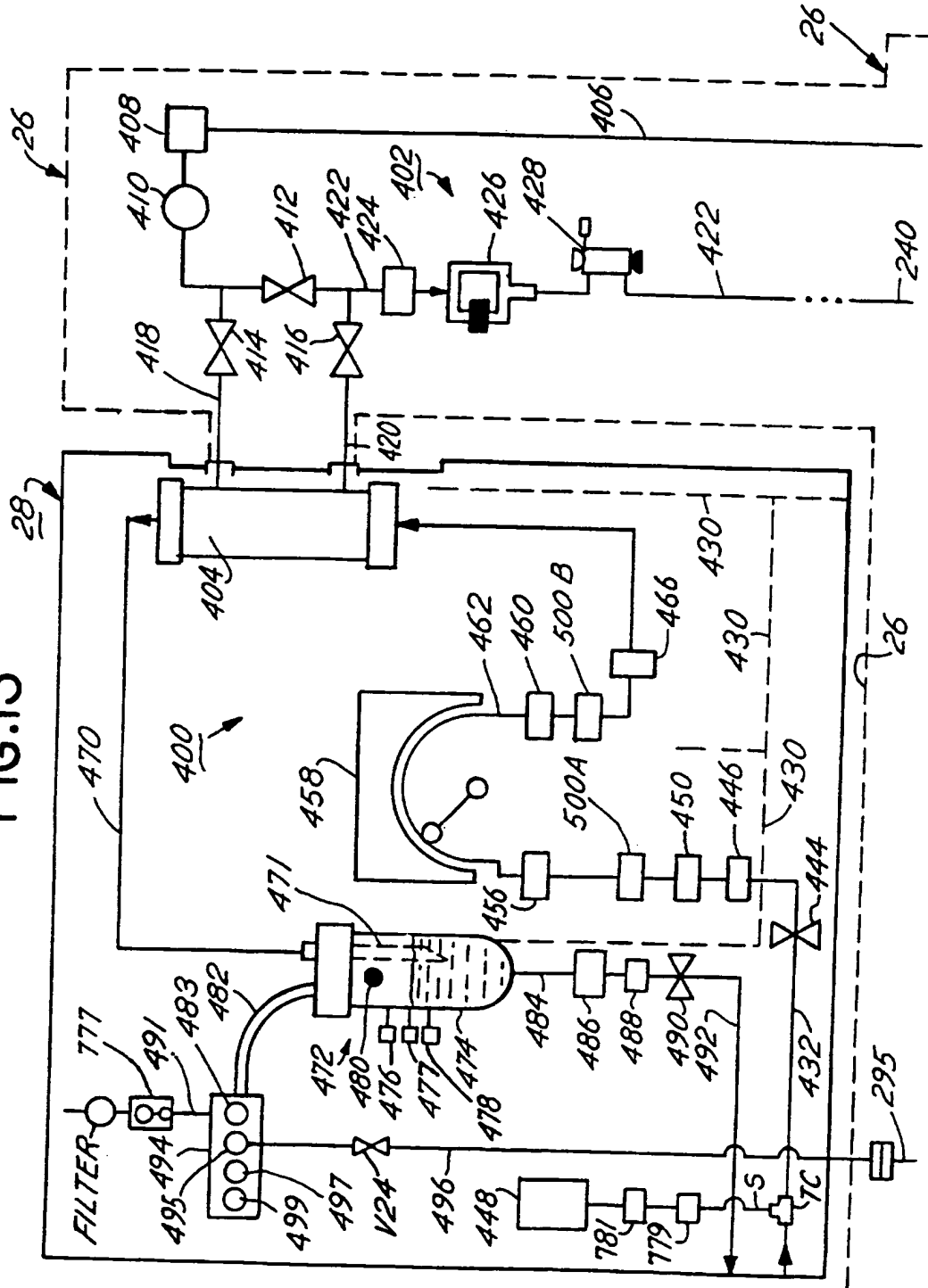

FIG.13



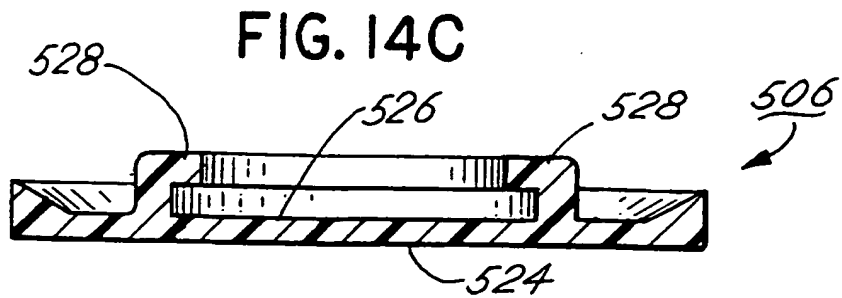
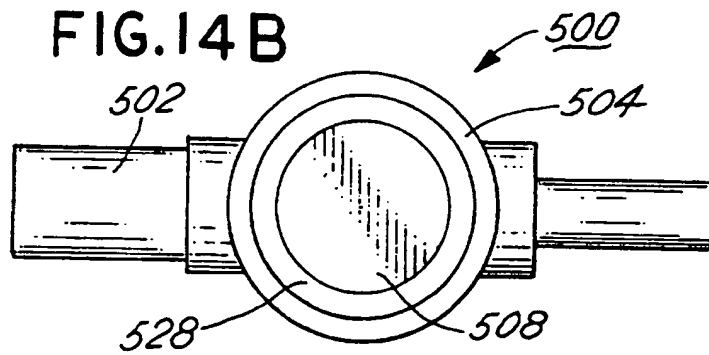
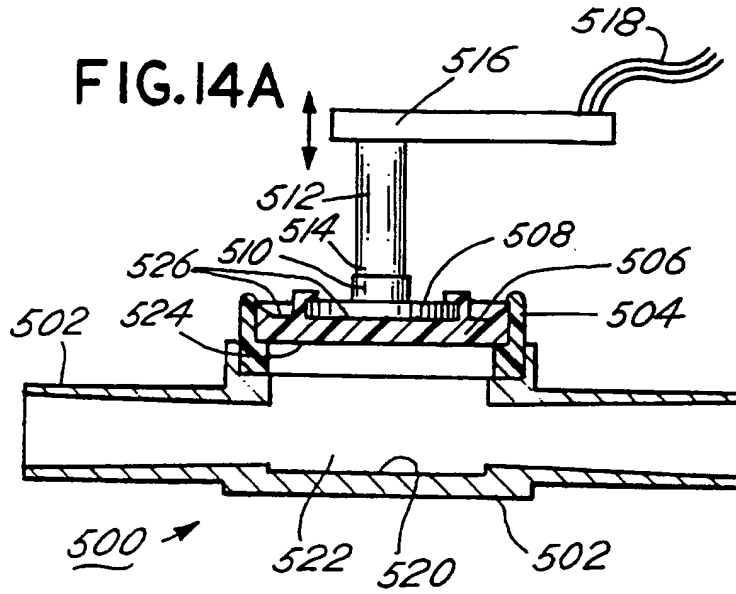
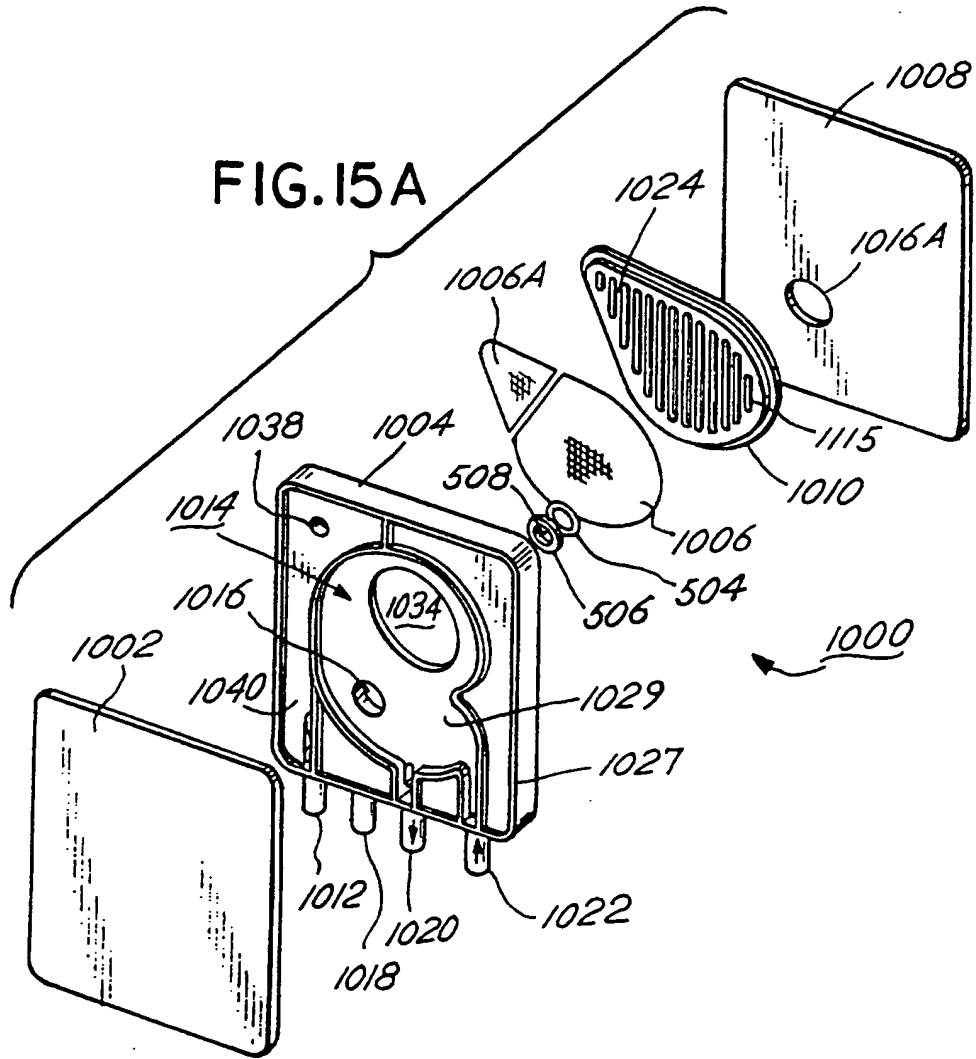

FIG. 15A



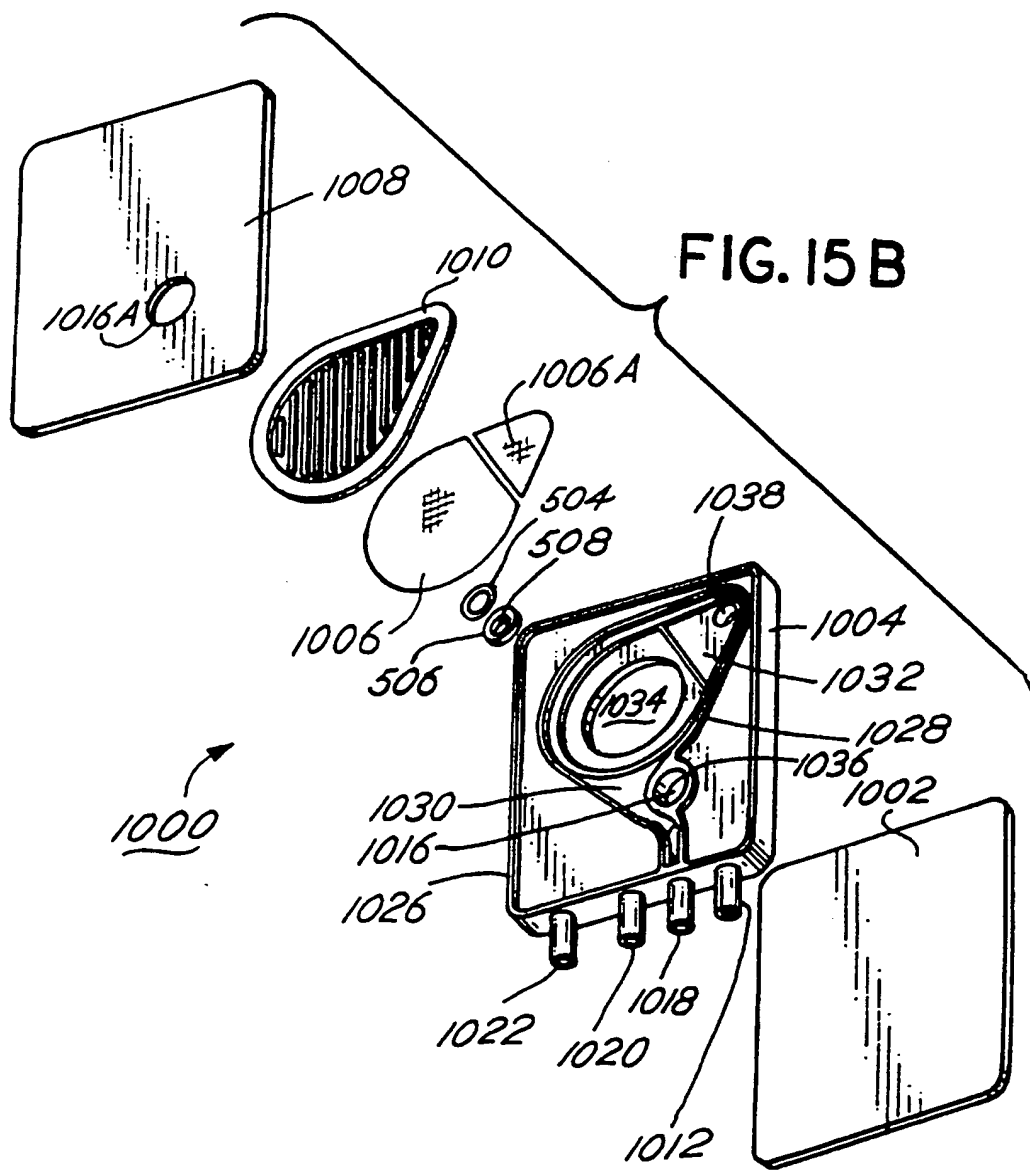

FIG.15C

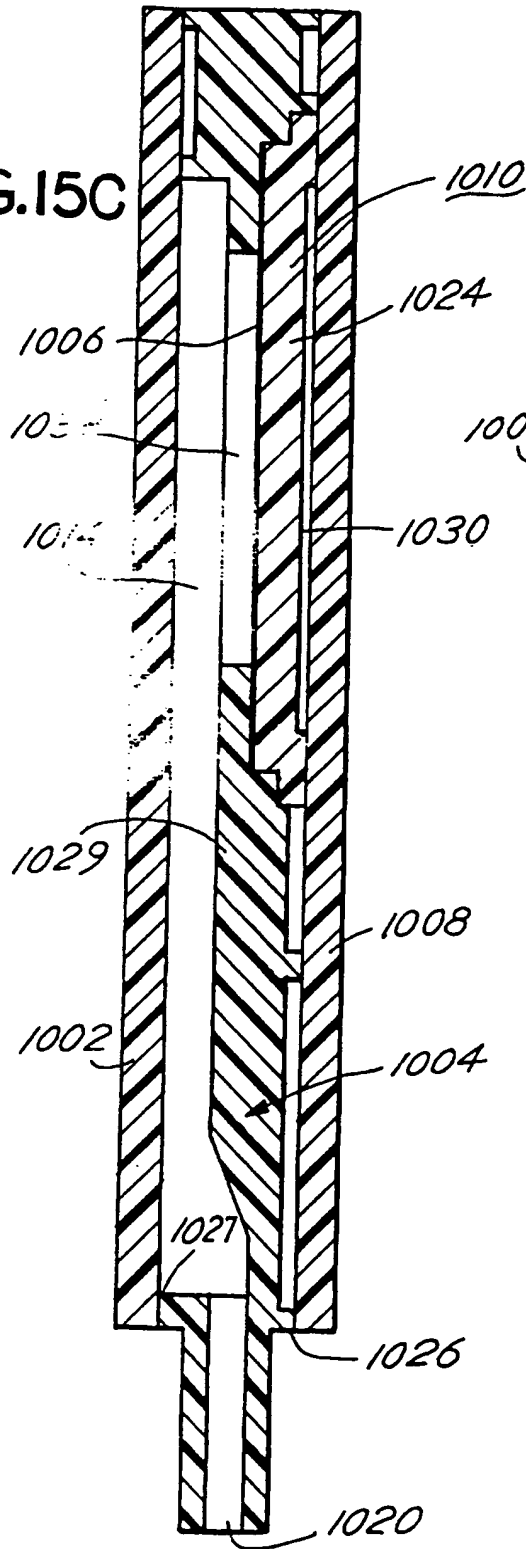
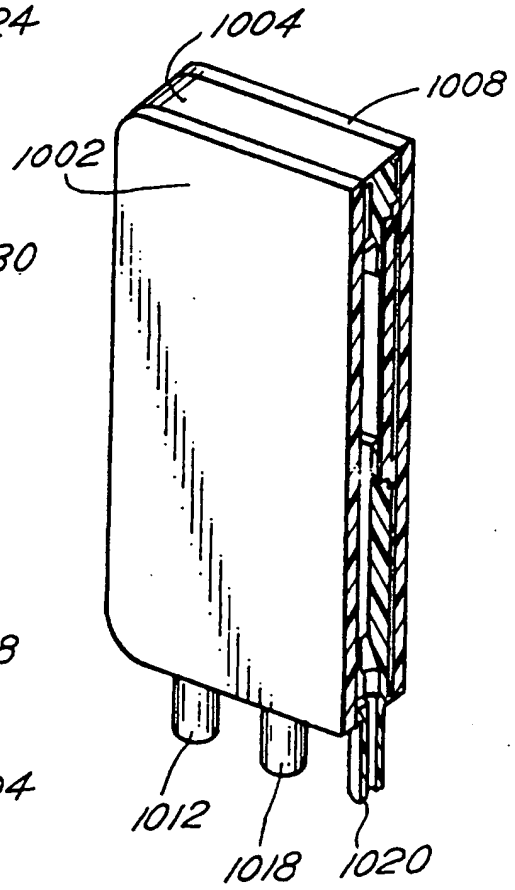

FIG.15D



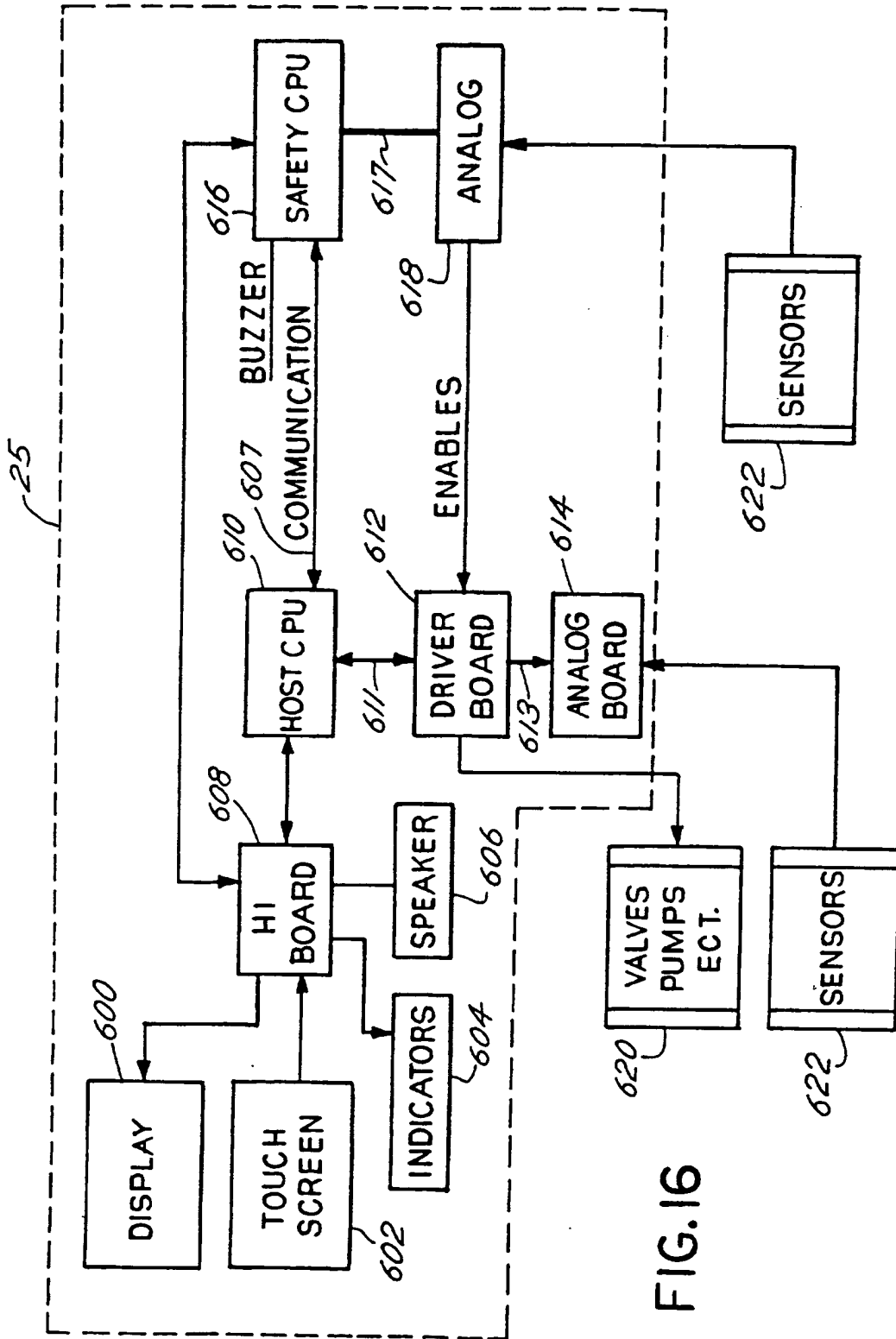

FIG. 16

FIG. 17

SYSTEM STATES

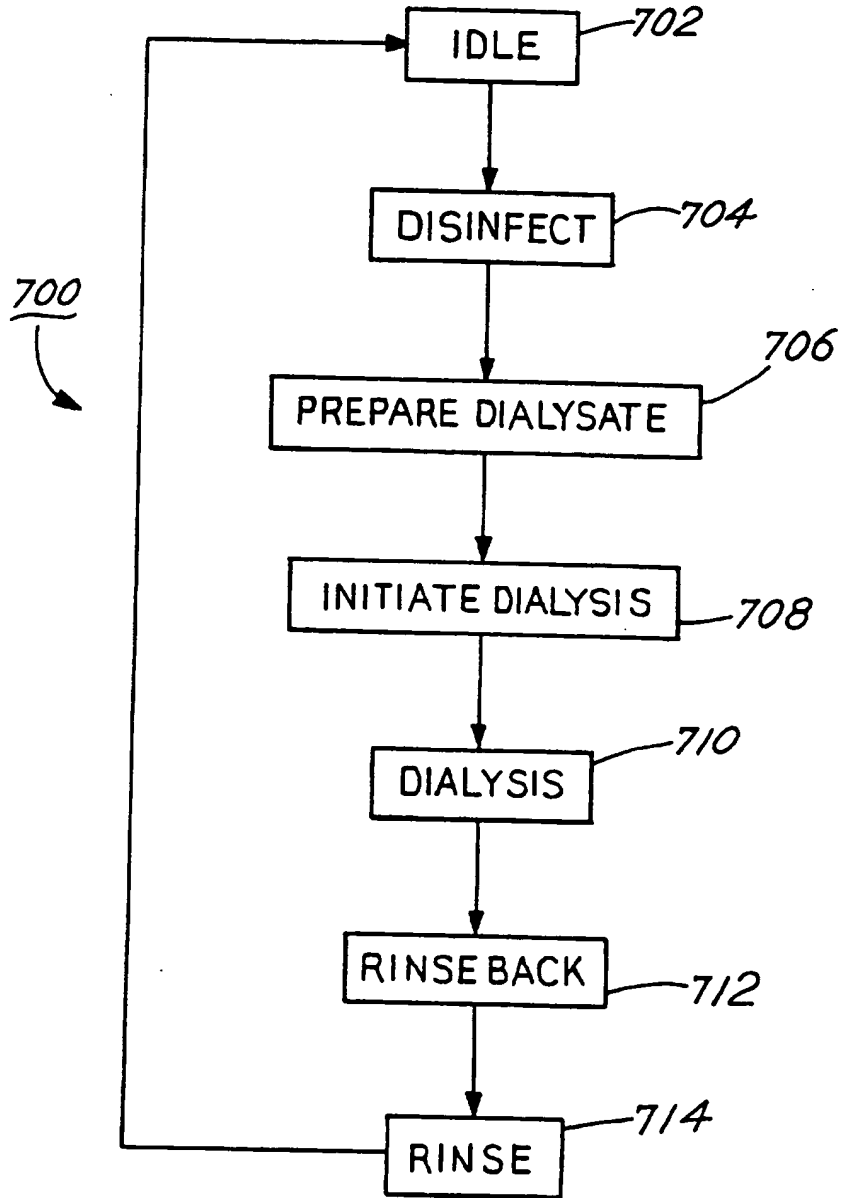
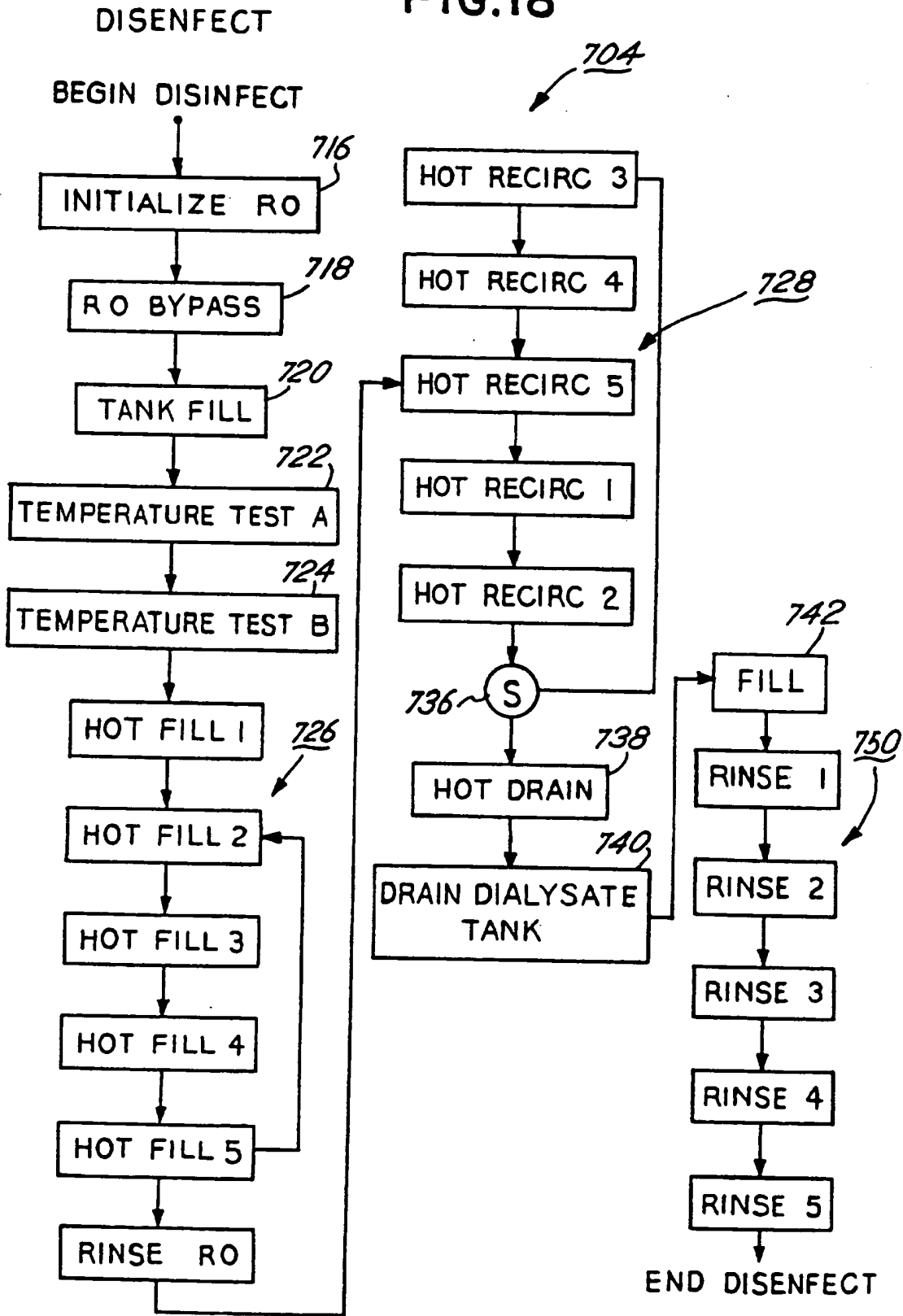

FIG.18



PREPARE DIALYSATE

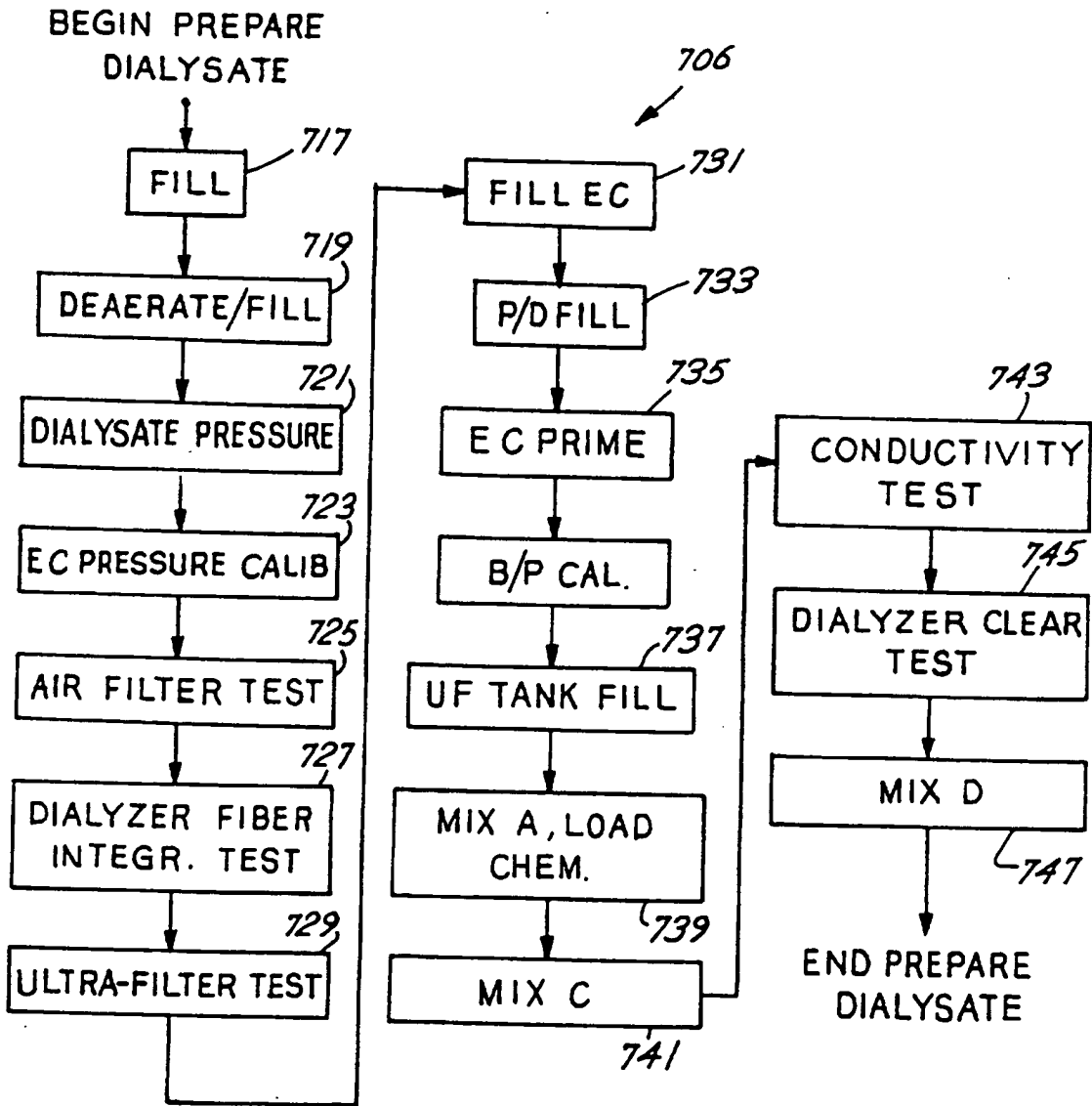
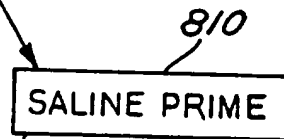
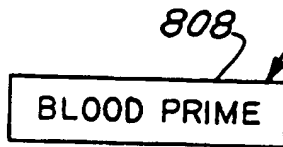
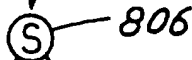
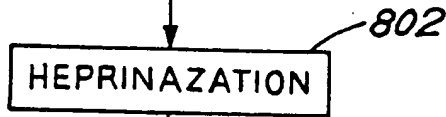
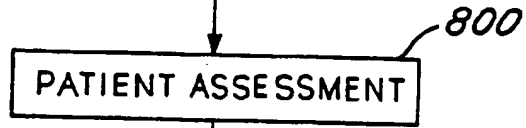

FIG.19

INITIATE DIALYSIS

BEGIN INITIATE DIALYSIS

708



END INITIATE DIALYSIS

FIG.20

FIG. 21

DIALYSIS

710
↓

BEGIN DIALYSIS

820

ESTABLISH BOUNDARY LAYER IN TANK

822
DIALYZE

⑤

824
BACKFLUSH

828
SALINE REINFUSION

830
Ⓜ

●

END DIALYSIS

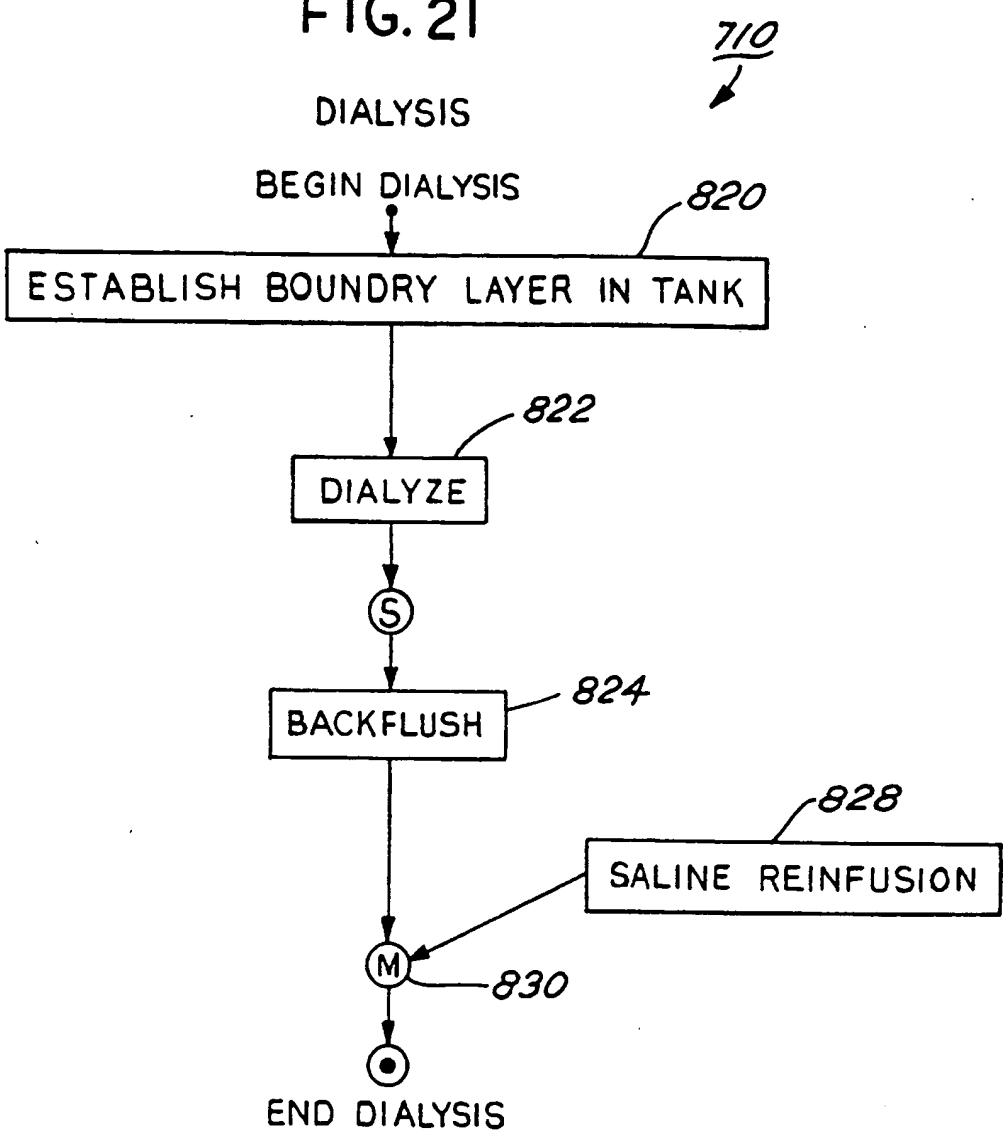

FIG. 22

RINSEBACK

712

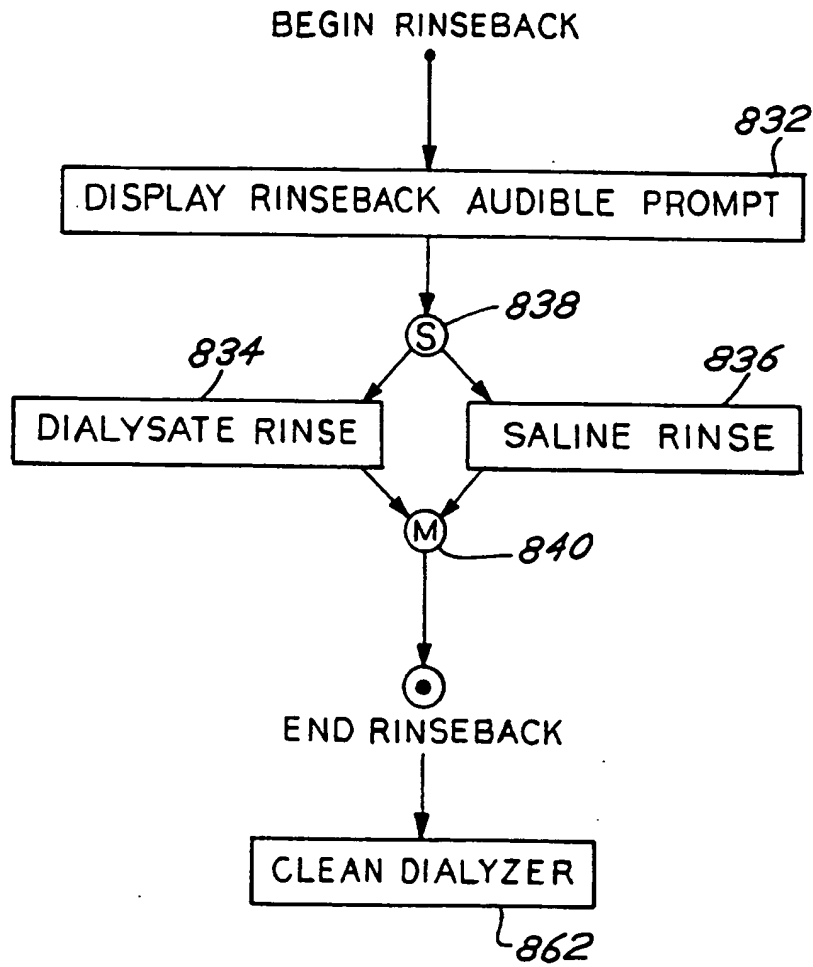
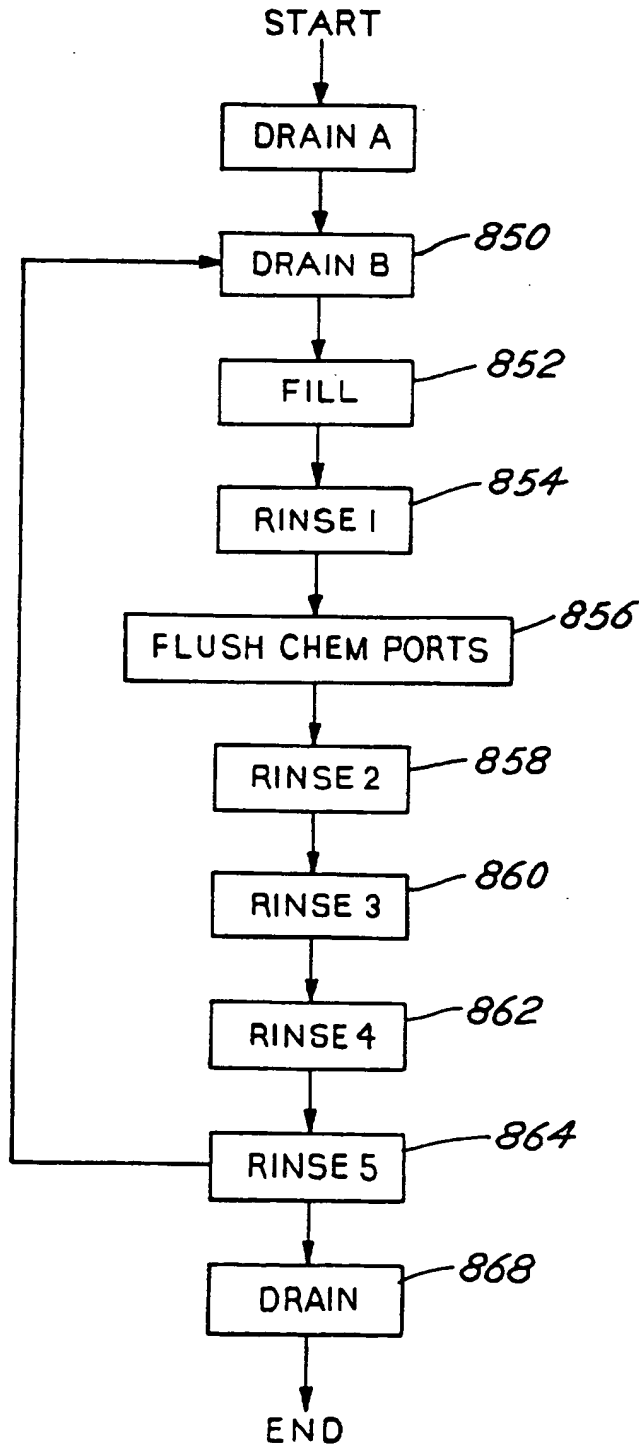
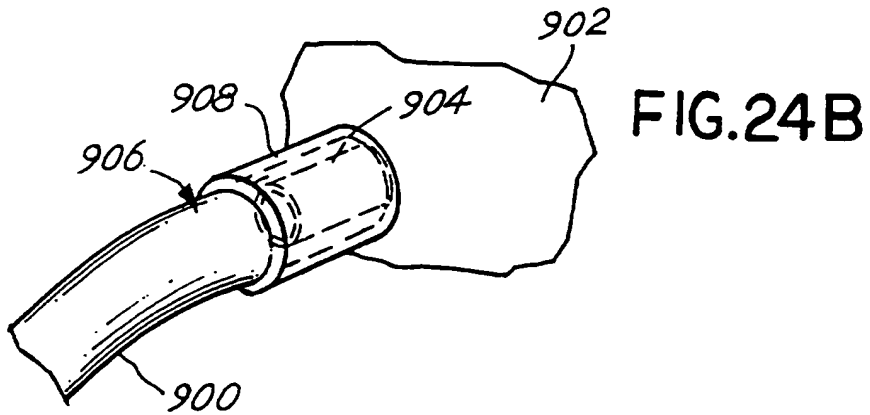
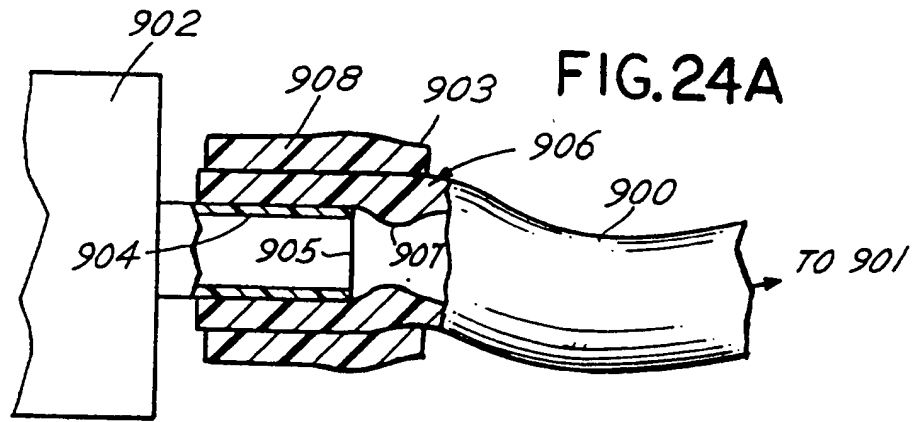
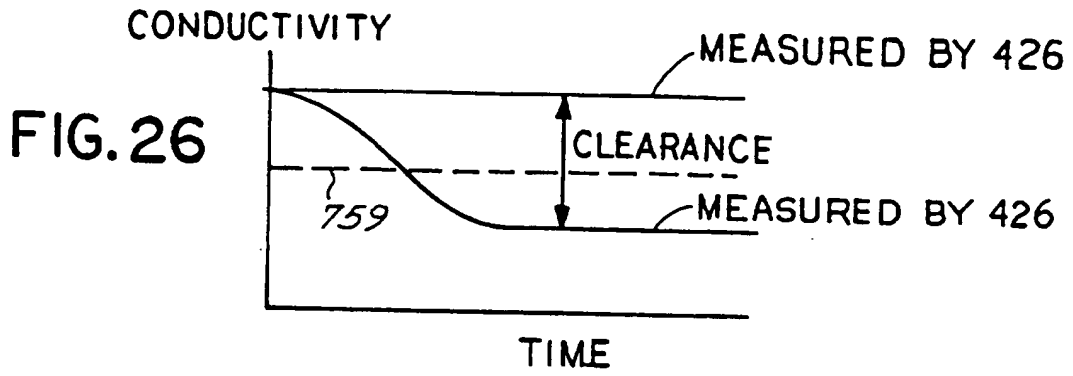

FIG.23

RINSE

714 ↘





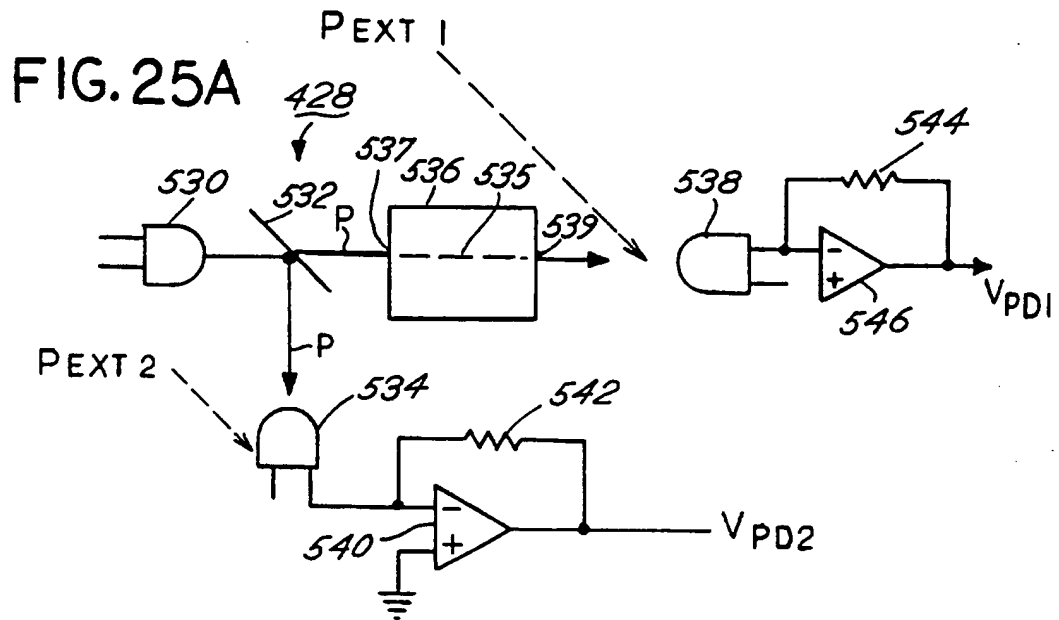

FIG. 25B

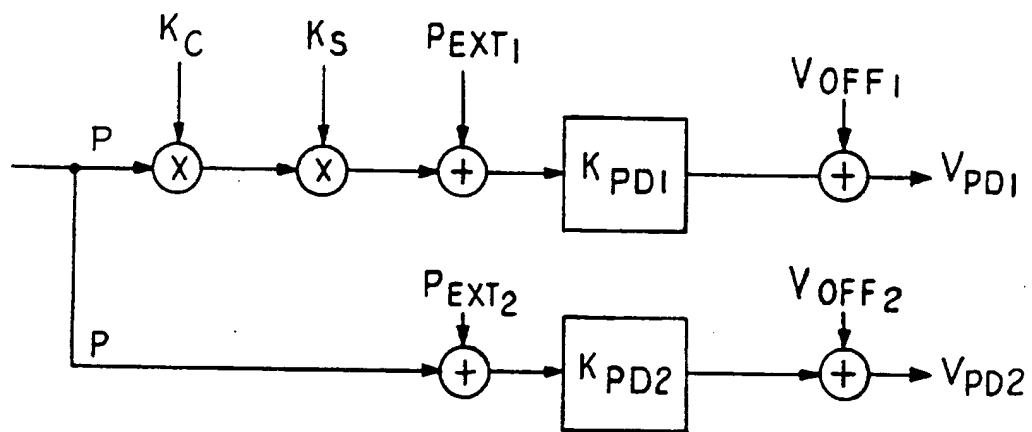

FIG. 27A

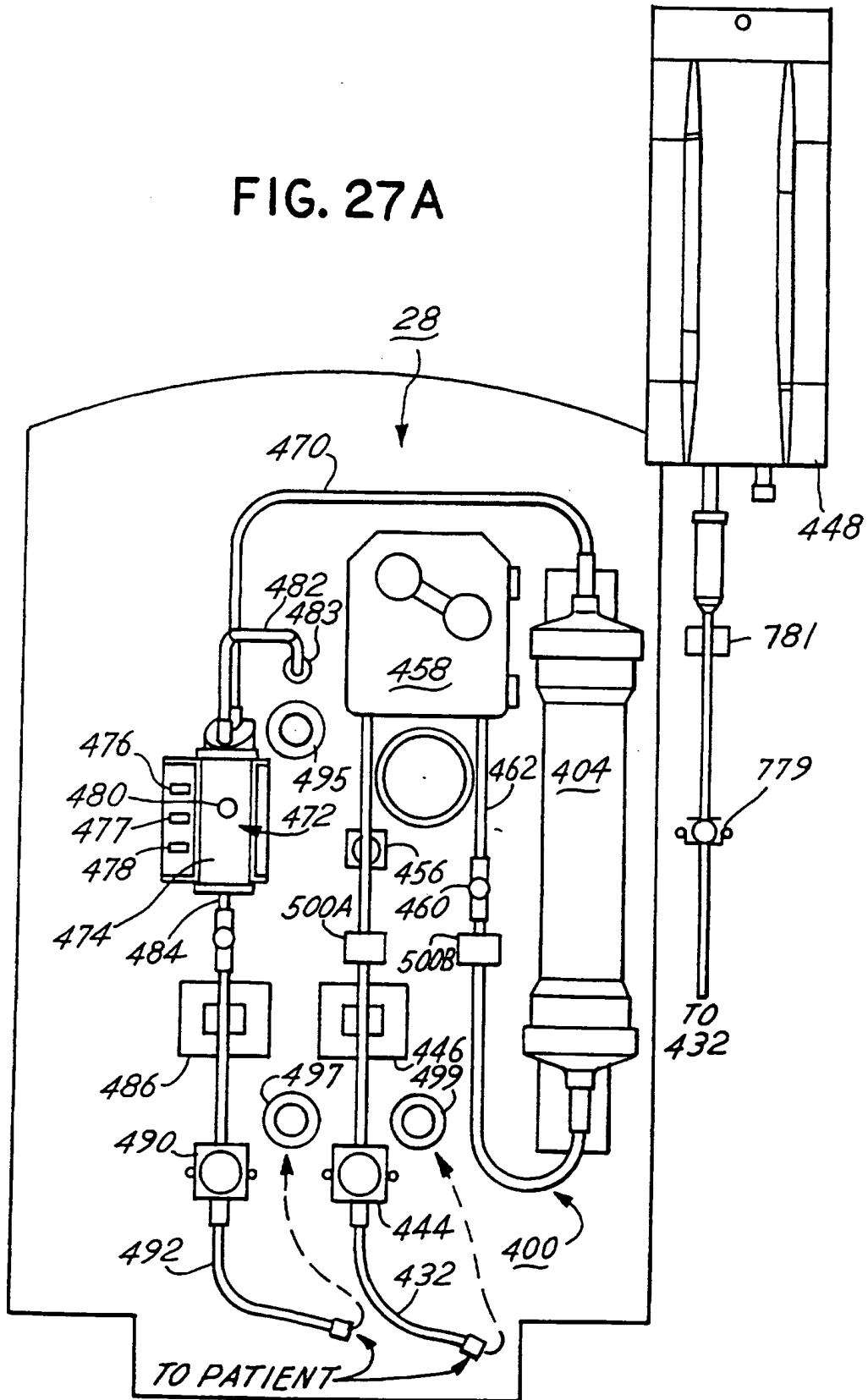

FIG. 27 B

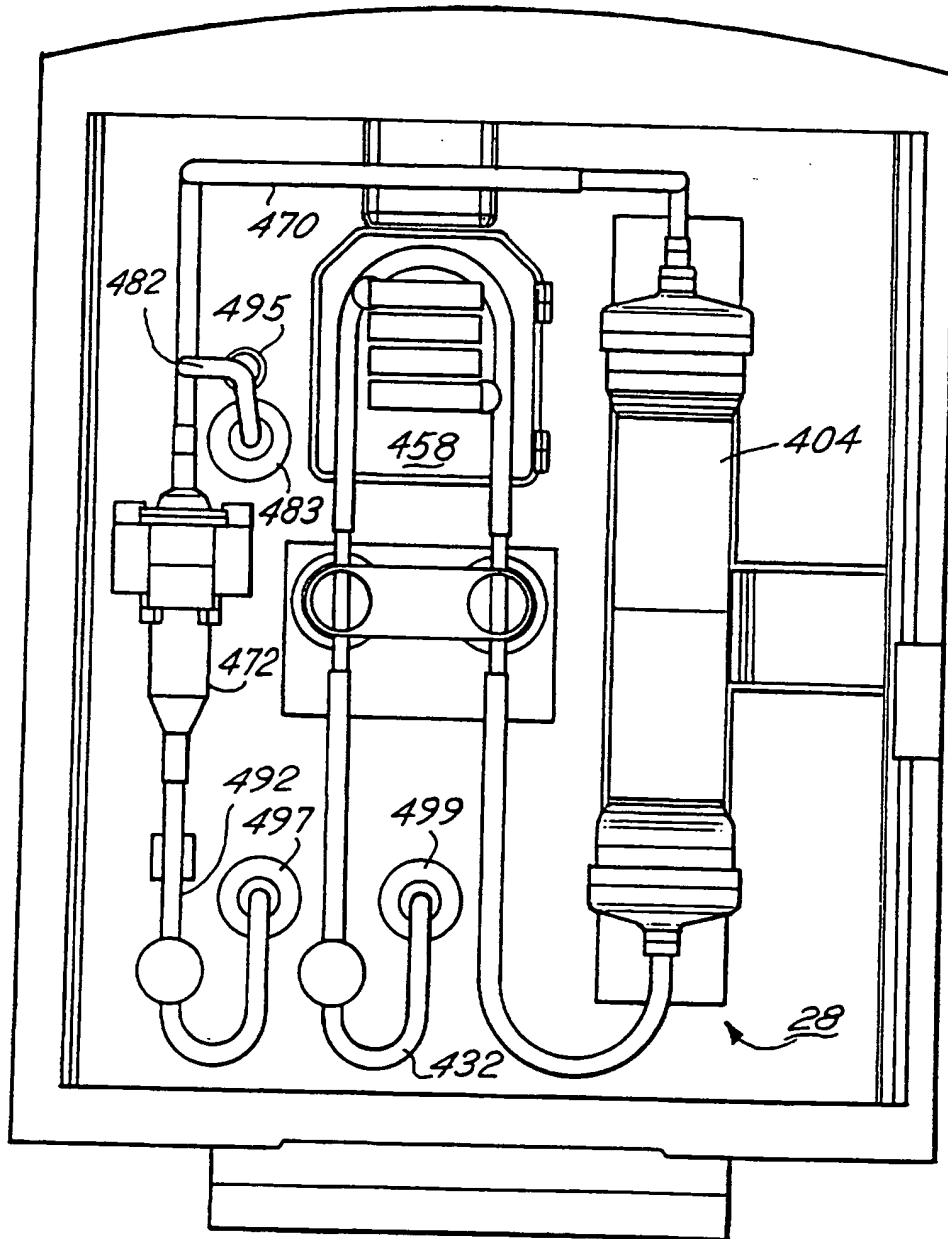
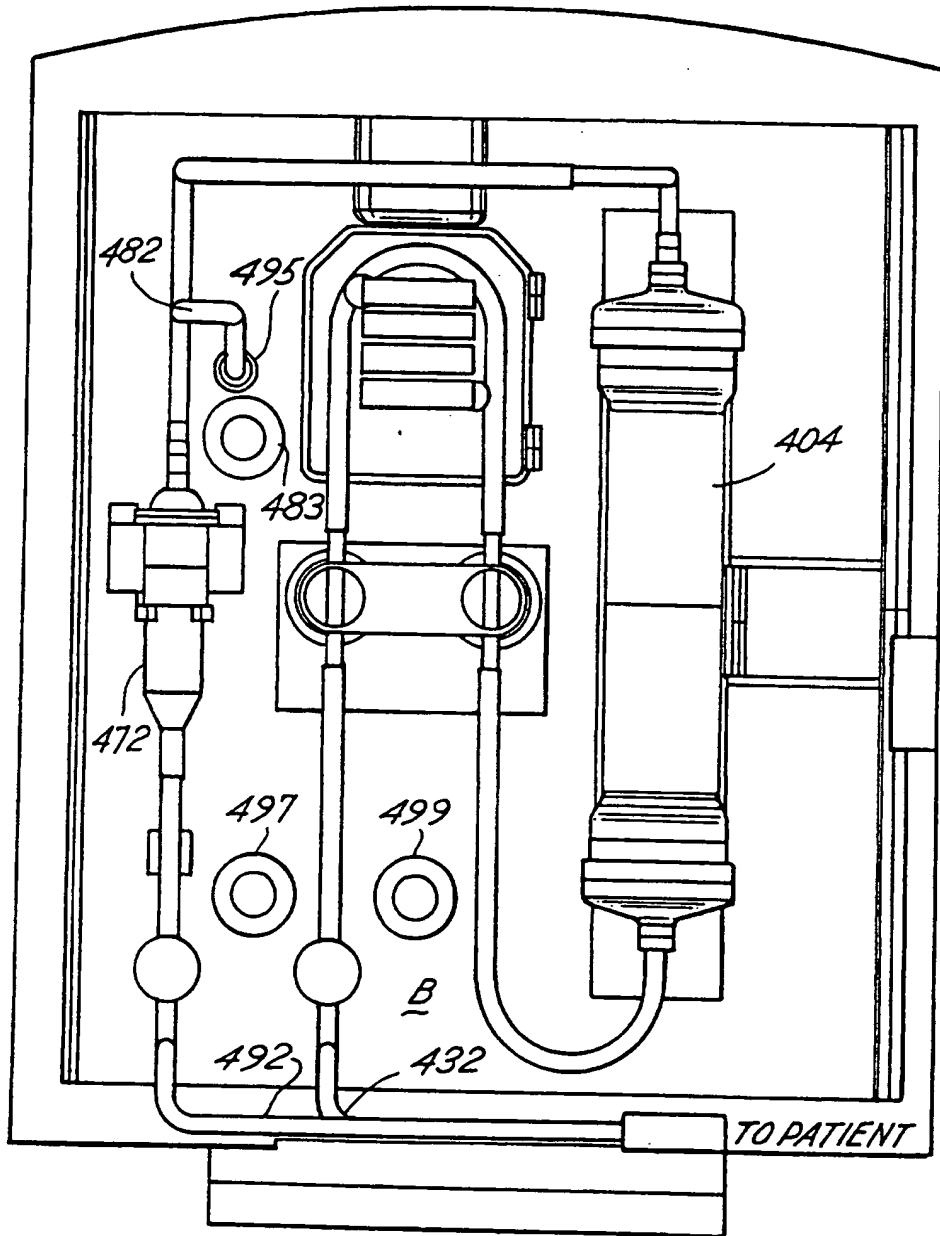

FIG. 27C



35/47

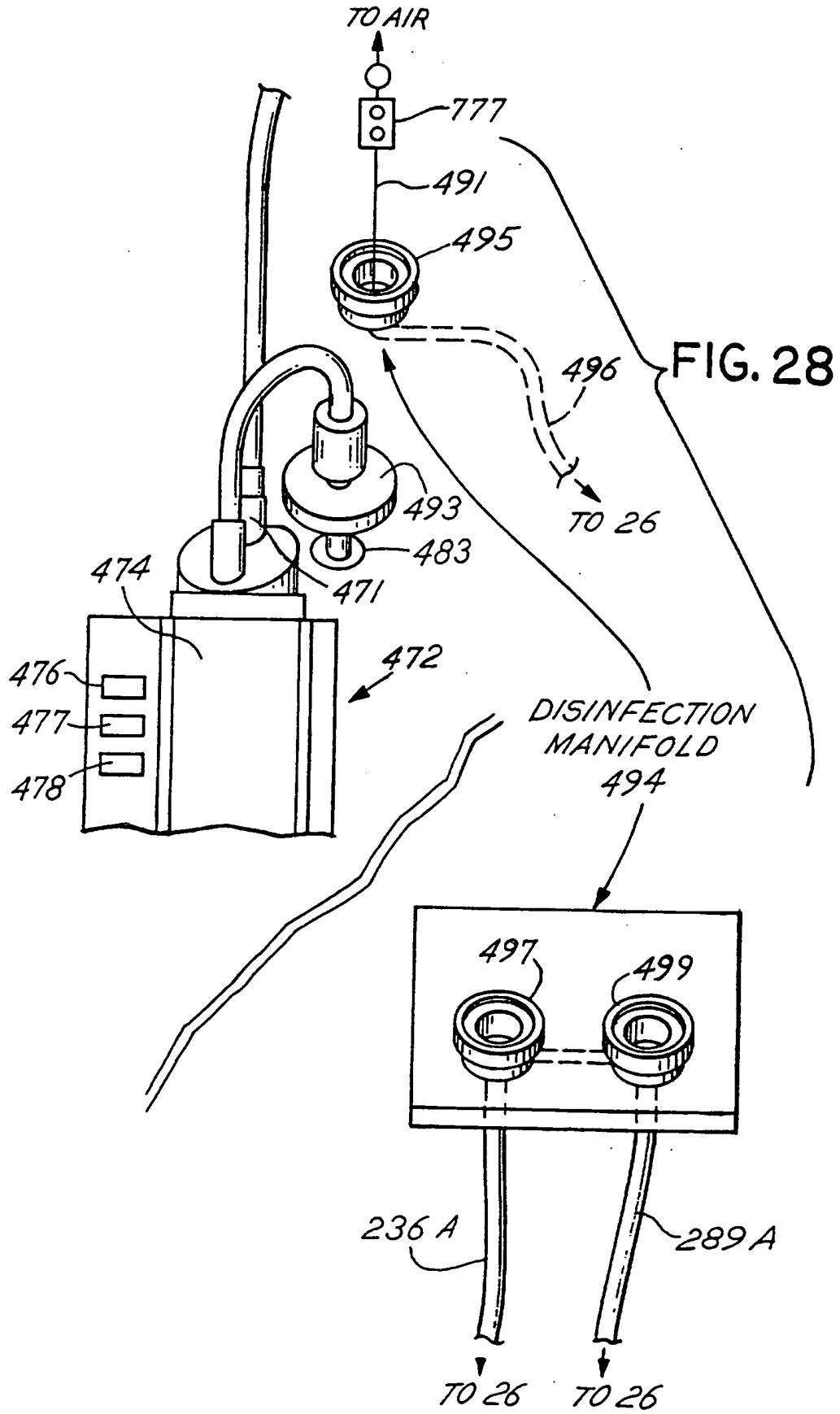

FIG. 29C

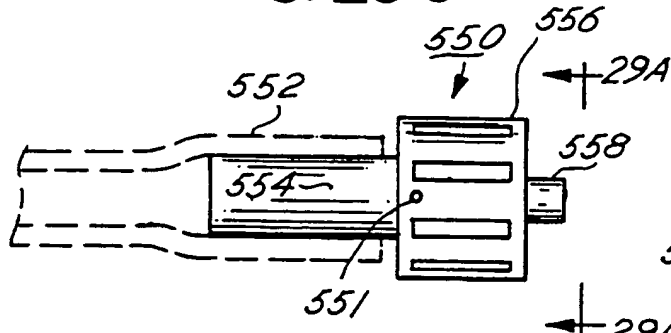

FIG. 29A

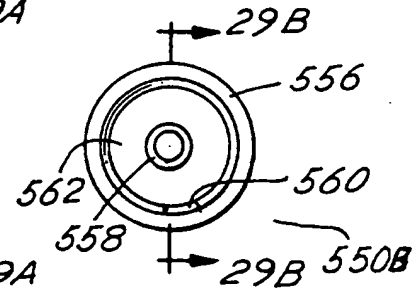

FIG. 29B

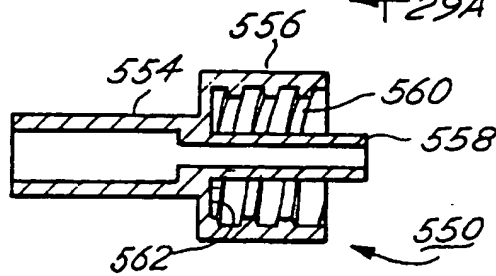

FIG. 30A

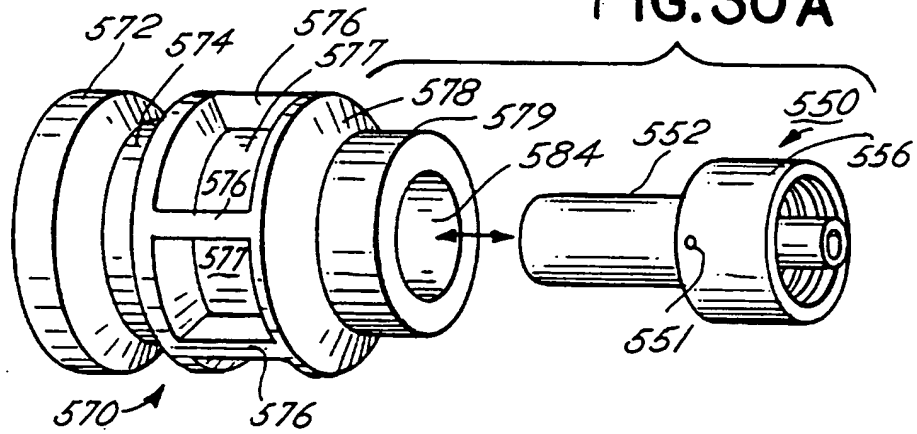

FIG. 30C

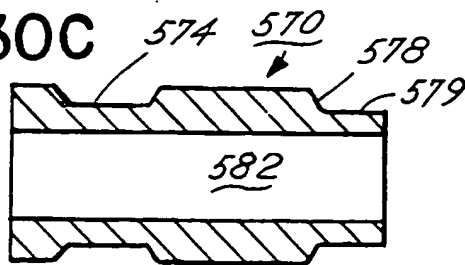

FIG. 30B

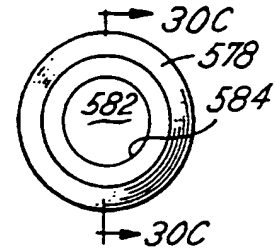

FIG.29D

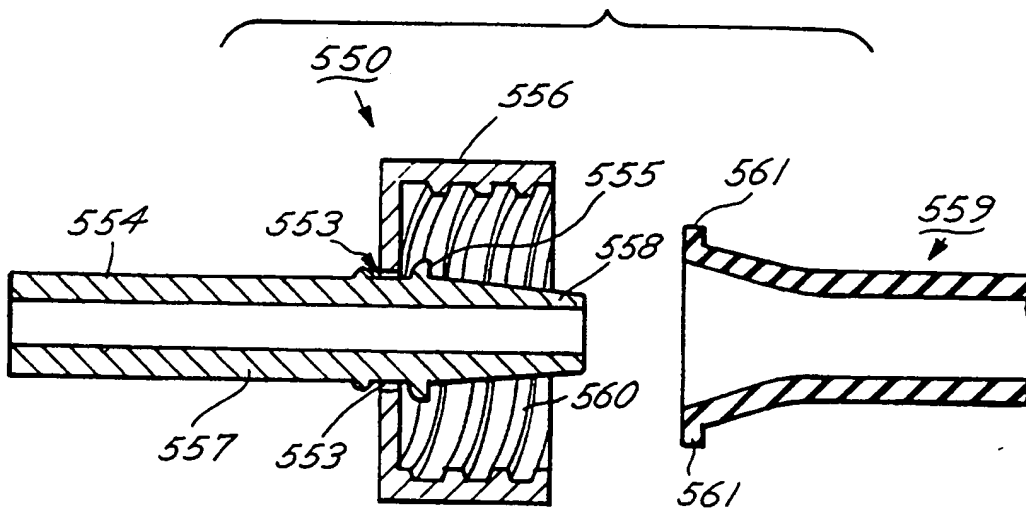

FIG. 30D

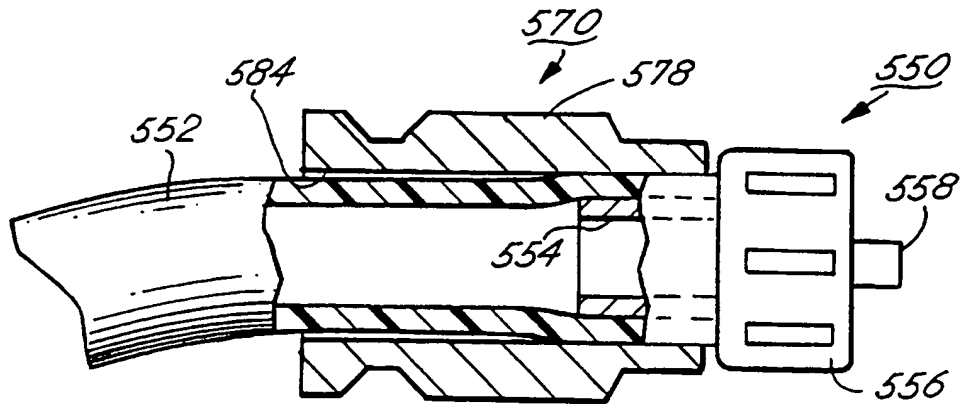

FIG. 30E

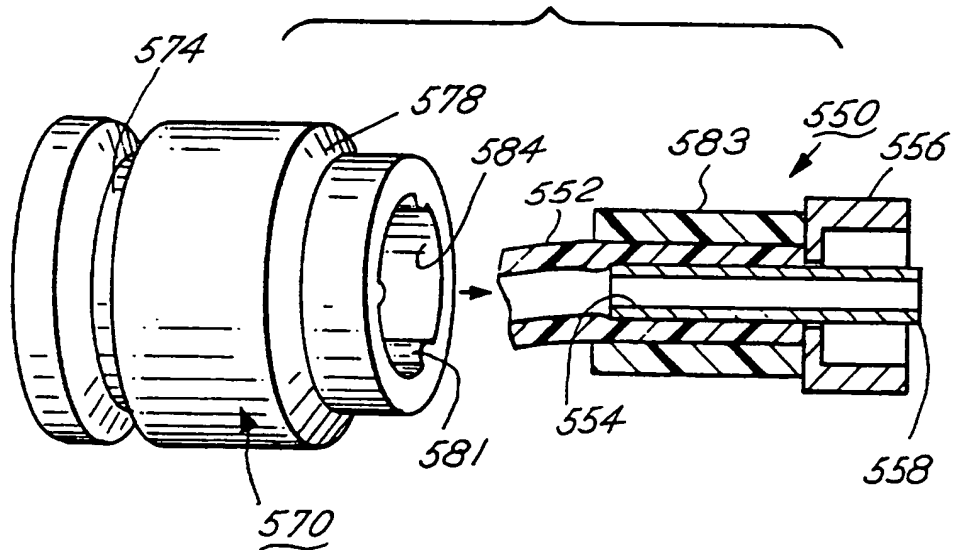

FIG. 30F

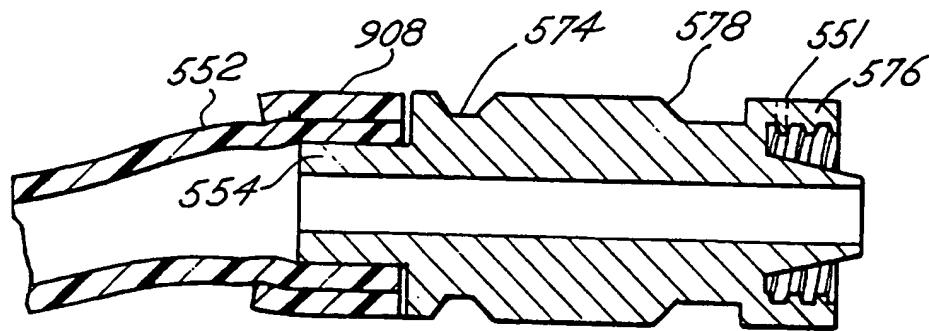
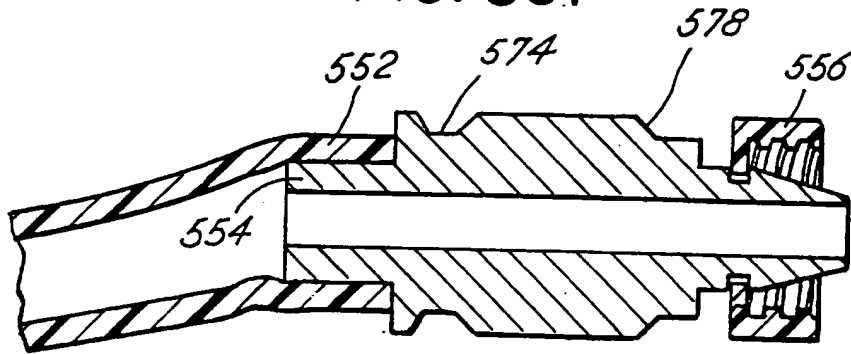

FIG. 30G

FIG.30I

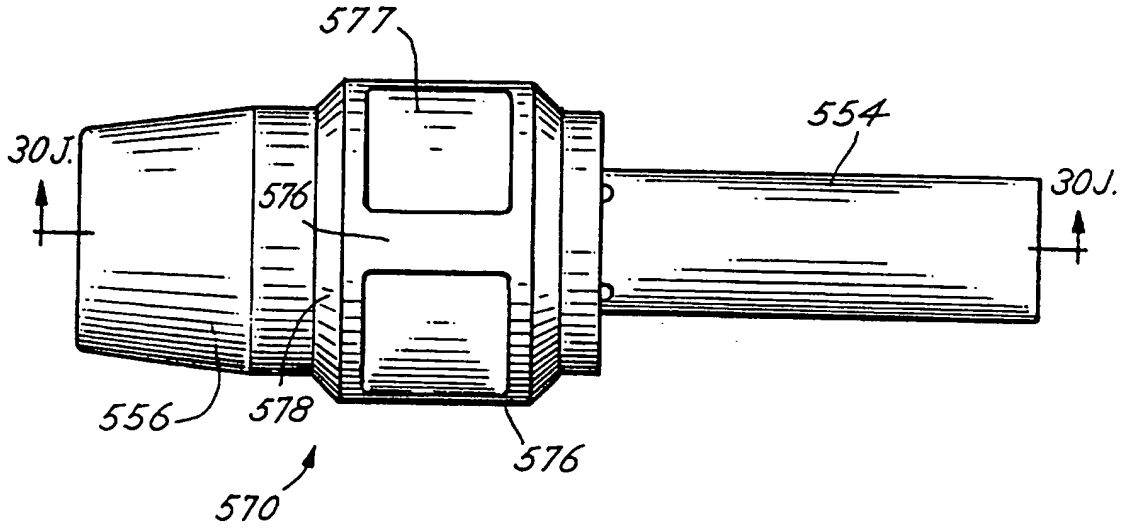

FIG.30H

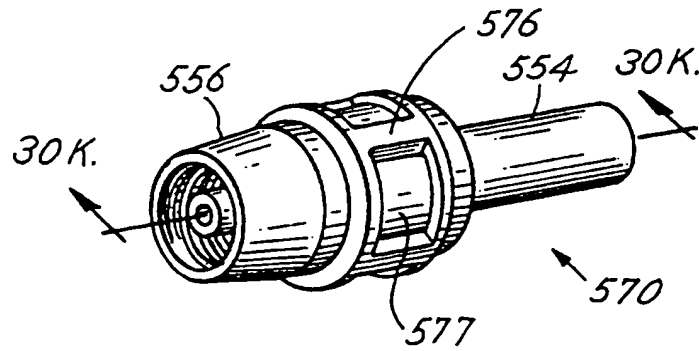

FIG.30J

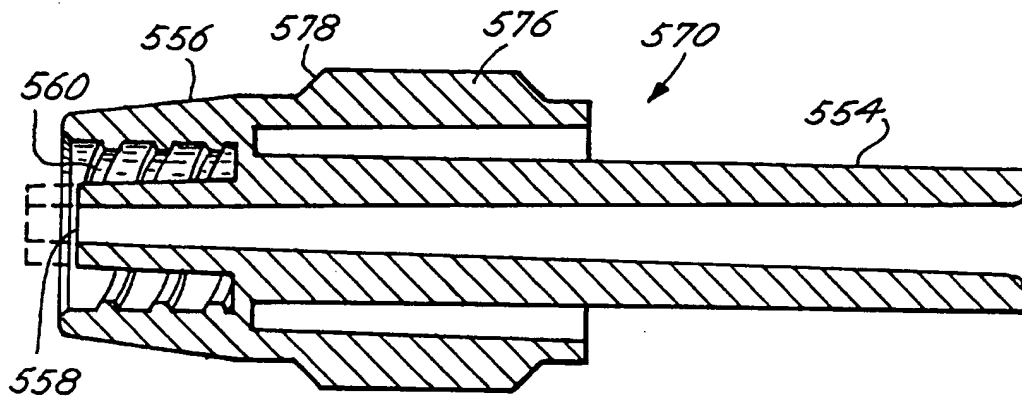
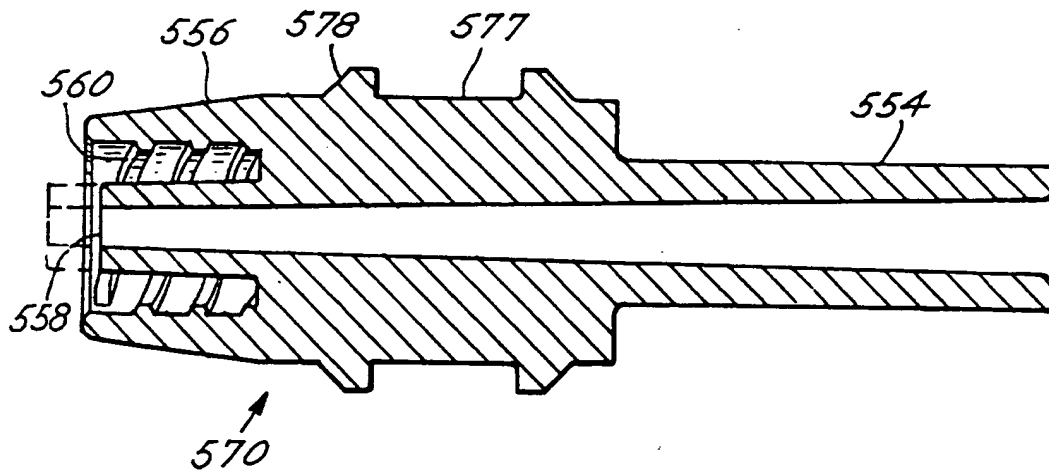

FIG.30K



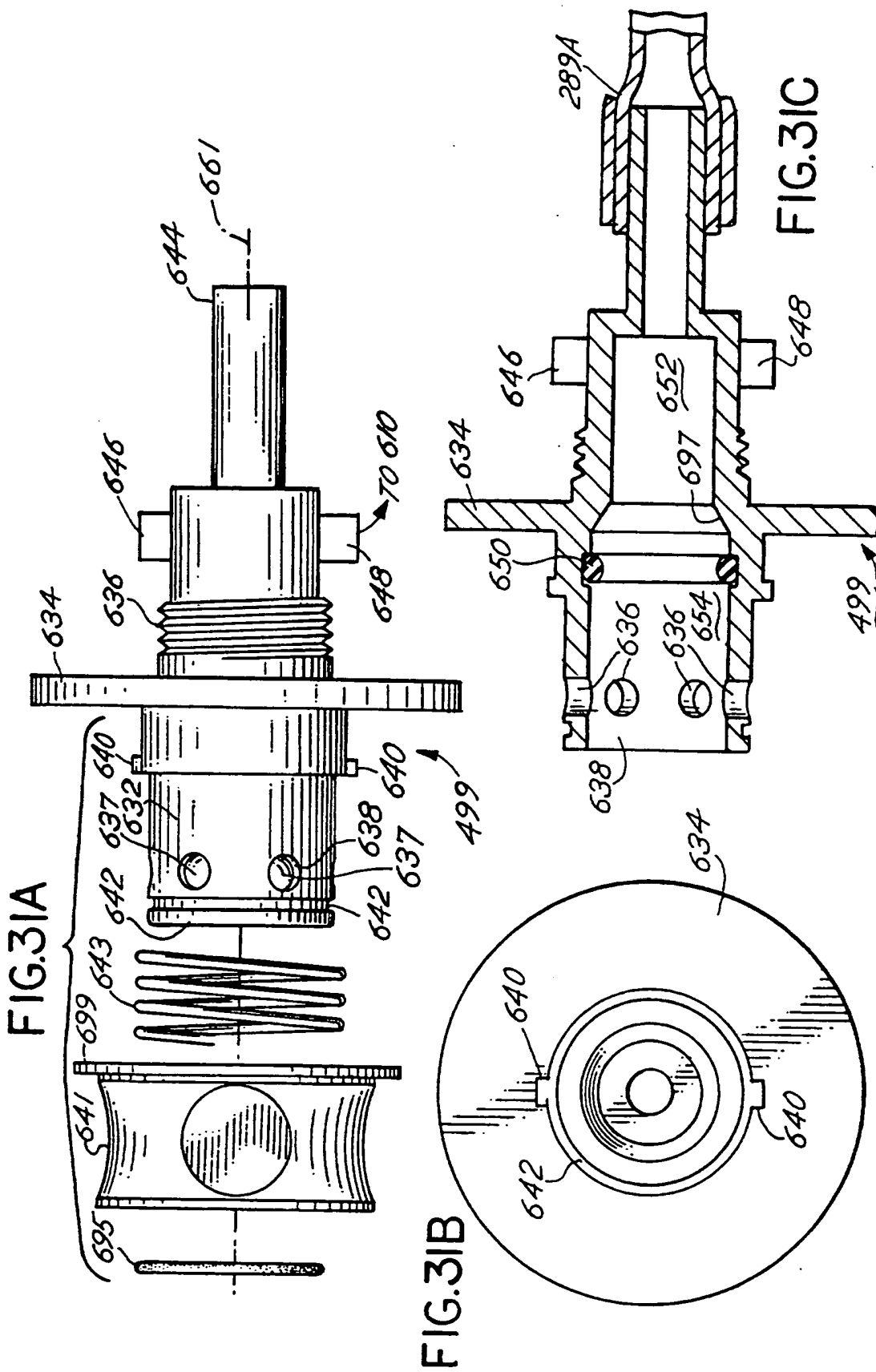

FIG.31E

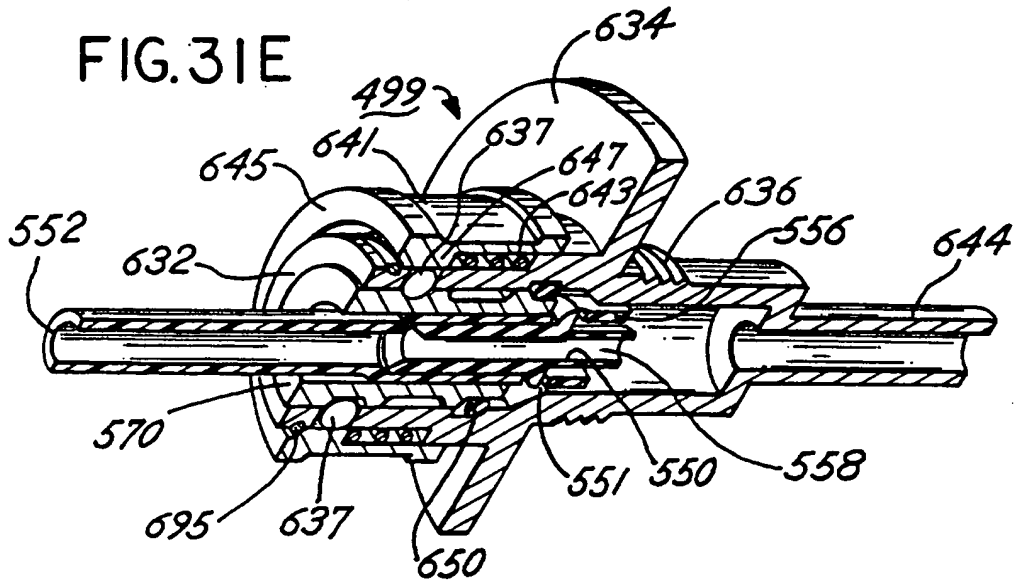

FIG.31 D

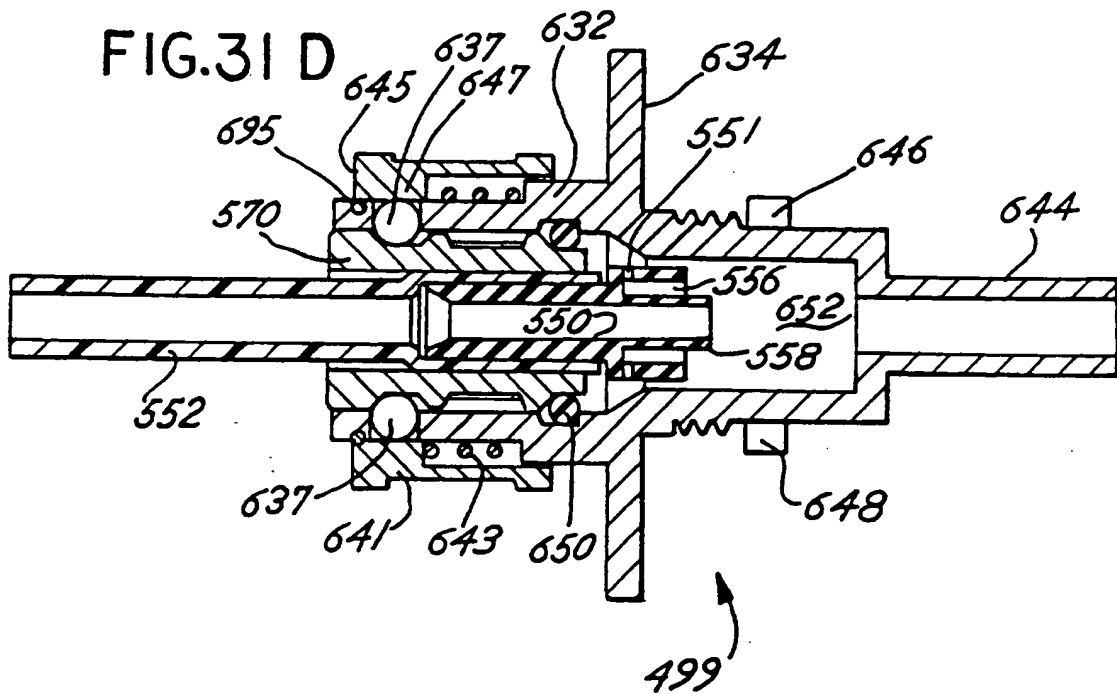

FIG.32A

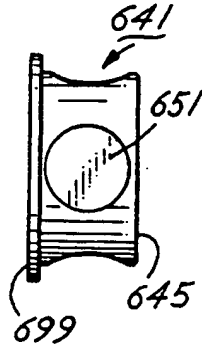

FIG.32B

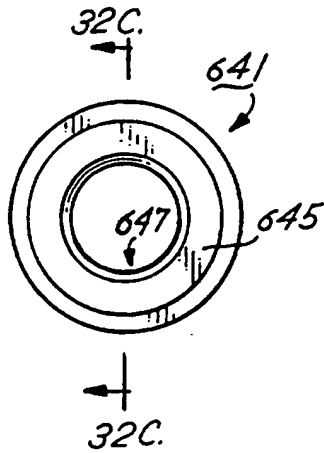

FIG.32C

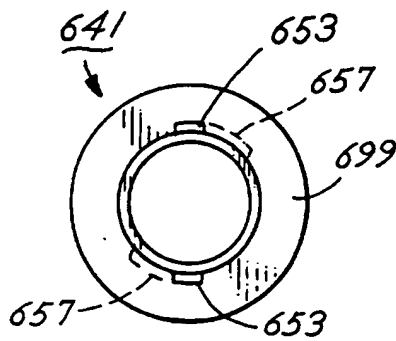
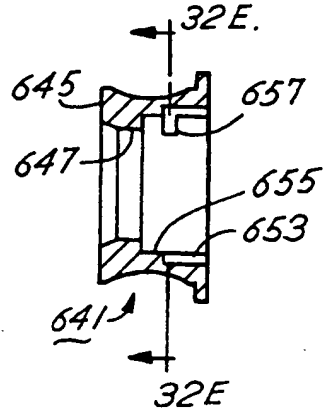

FIG.32D

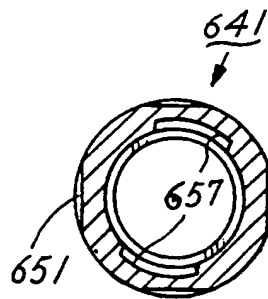

FIG.32E

FIG. 33

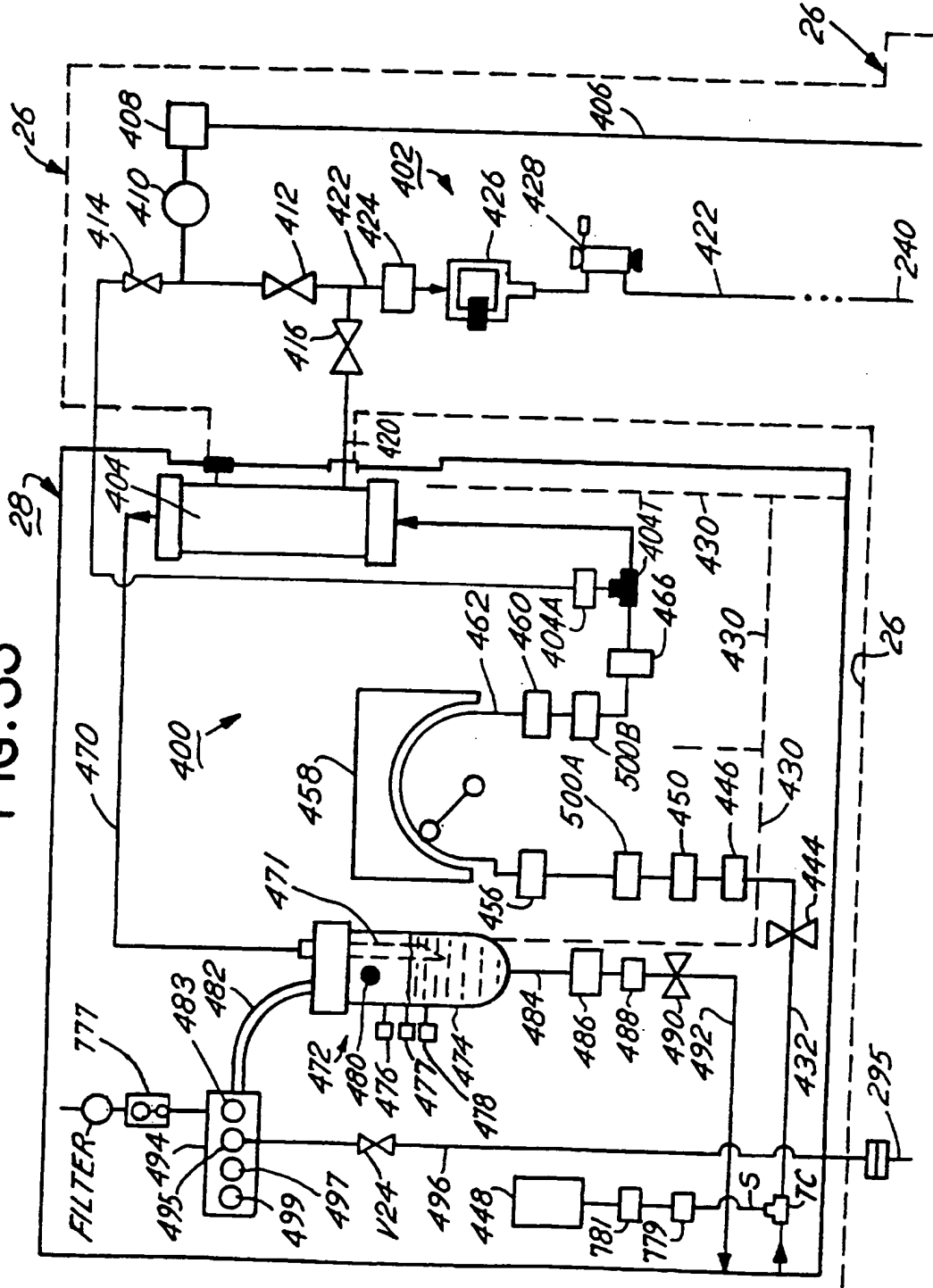

FIG. 34

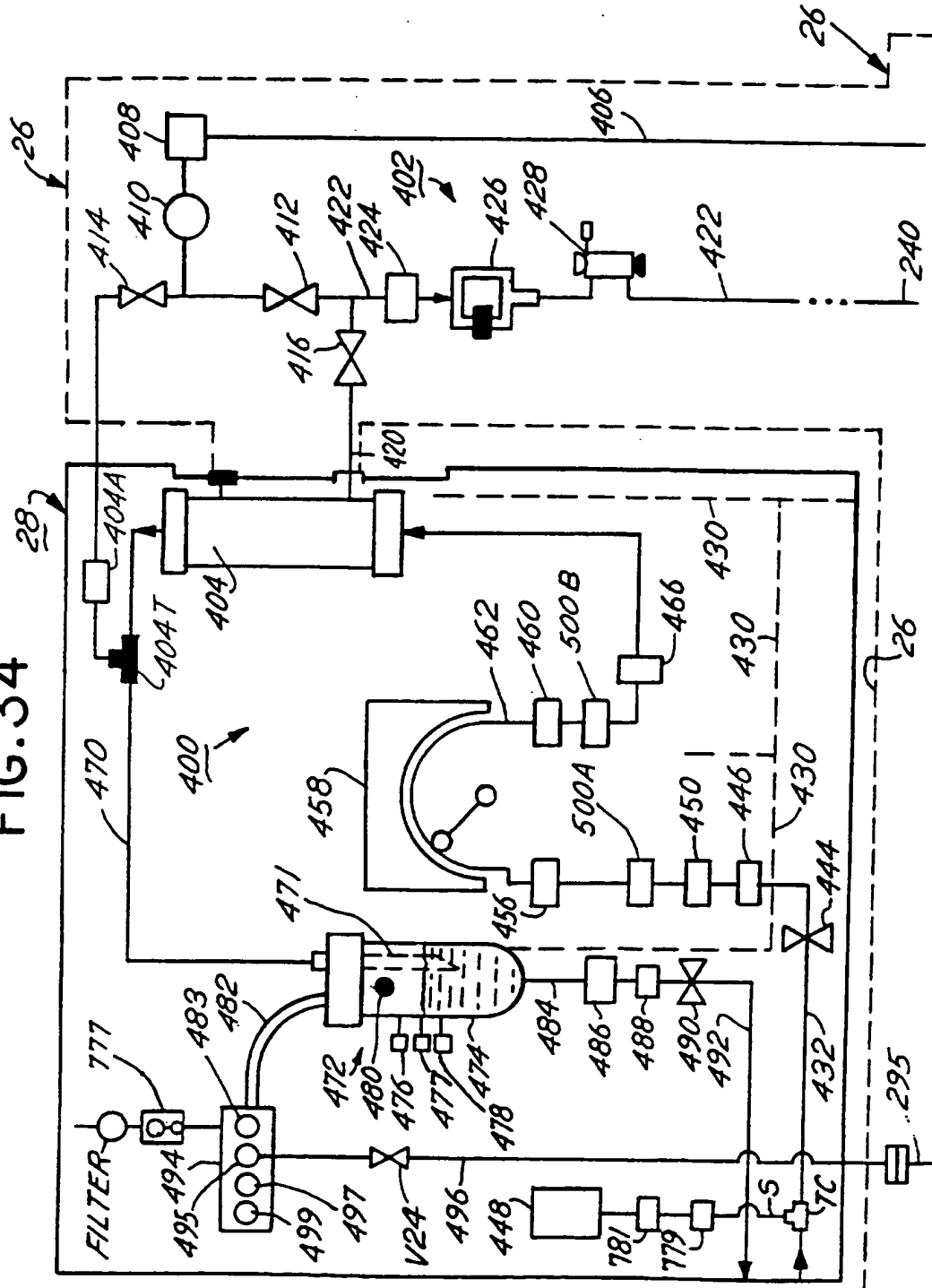
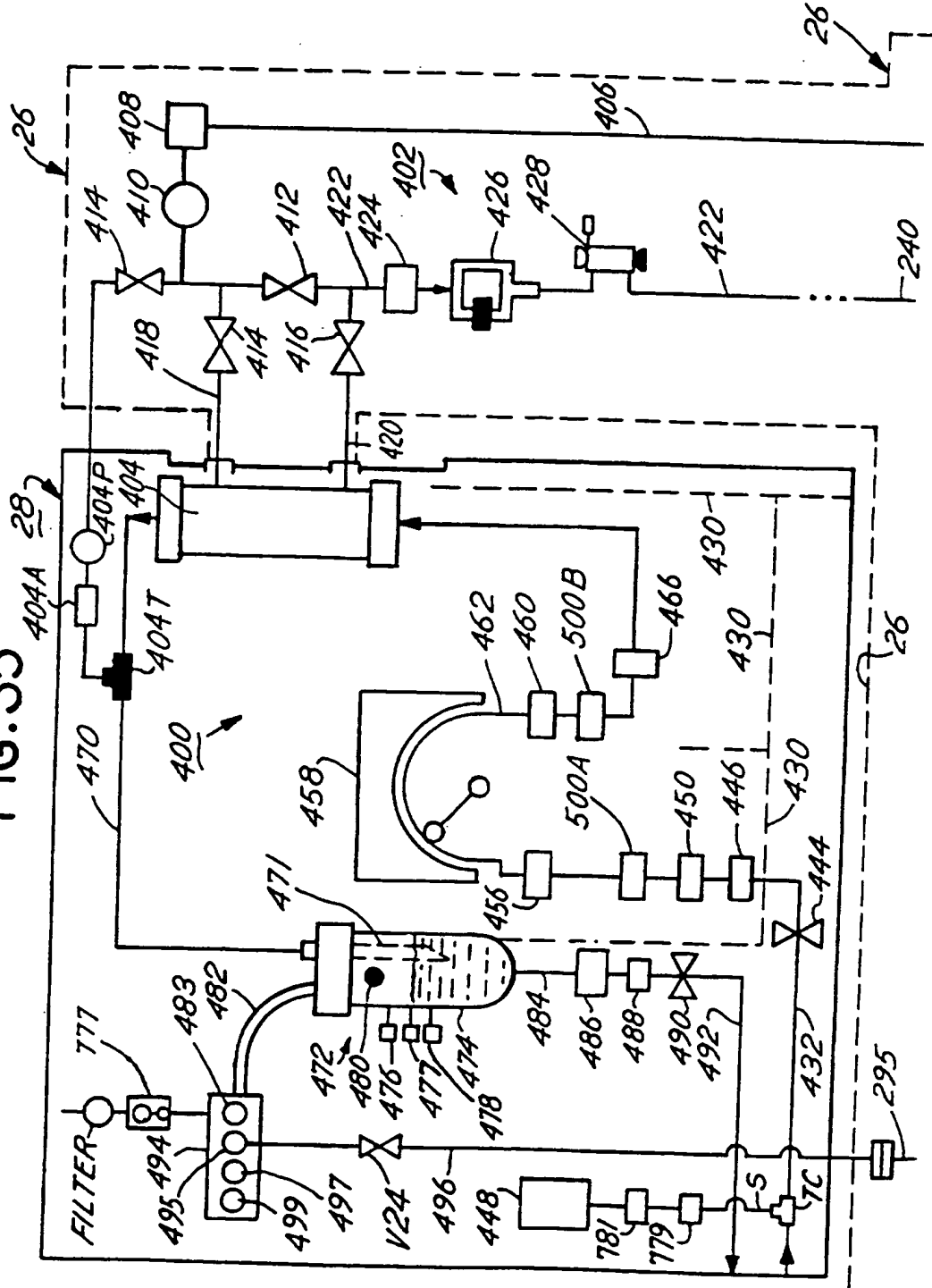

FIG. 35



INTERNATIONAL SEARCH REPORT

International application No.
PCT/US96/01885

A. CLASSIFICATION OF SUBJECT MATTER

IPC(6) : Please See Extra Sheet.
US CL : Please See Extra Sheet.

According to International Patent Classification (IPC) or to both national classification and IPC

B. FIELDS SEARCHED

Minimum documentation searched (classification system followed by classification symbols)

U.S. : Please See Extra Sheet.

Documentation searched other than minimum documentation to the extent that such documents are included in the fields searched

Electronic data base consulted during the international search (name of data base and, where practicable, search terms used)

C. DOCUMENTS CONSIDERED TO BE RELEVANT

Category*	Citation of document, with indication, where appropriate, of the relevant passages	Relevant to claim No.
Y	US 3,352,779 A (A.J. AUSTIN ET AL) 14 NOVEMBER 1967 (14.11.67), see entire document.	1-11
Y,P	US 5,401,421 A (R. BLUM) 28 MARCH 1995 (28.03.95), see entire document.	1-4
Y	US 5,336,165 A (Z.J. TWARDOWSKI) 09 AUGUST 1994 (09.08.94), see entire document.	1-4, 19-21, 42-48, 58-62, 63-68
Y	US 5,326,476 A (J.B. GROGAN ET AL) 05 JULY 1994 (05.07.94), see entire document.	5-18
Y	US 4,610,790 A (A.R. RETI ET AL) 09 SEPTEMBER 1986 (09.09.86), see entire document.	1-11, 49-57

Further documents are listed in the continuation of Box C. See patent family annex.

* Special categories of cited documents:	*T	later document published after the international filing date or priority date and not in conflict with the application but cited to understand the principle or theory underlying the invention
A document defining the general state of the art which is not considered to be of particular relevance	*X	document of particular relevance; the claimed invention cannot be considered novel or cannot be considered to involve an inventive step when the document is taken alone
E earlier document published on or after the international filing date	*Y	document of particular relevance; the claimed invention cannot be considered to involve an inventive step when the document is combined with one or more other such documents, such combination being obvious to a person skilled in the art
L document which may throw doubts on priority claim(s) or which is cited to establish the publication date of another citation or other special reason (as specified)	*Z	document member of the same patent family
O document referring to an oral disclosure, use, exhibition or other means		
P document published prior to the international filing date but later than the priority date claimed		

Date of the actual completion of the international search

17 MAY 1996

Date of mailing of the international search report

03 JUN 1996

Name and mailing address of the ISA/US
Commissioner of Patents and Trademarks
Box PCT
Washington, D.C. 20231

Facsimile No. (703) 305-3230

Authorized officer

SUN UK KIM

Telephone No. (703) 308-2350

INTERNATIONAL SEARCH REPORT

International application No.
PCT/US96/01885

C (Continuation). DOCUMENTS CONSIDERED TO BE RELEVANT		
Category*	Citation of document, with indication, where appropriate, of the relevant passages	Relevant to claim No.
Y	US 5,032,265 A (A.D. JHA ET AL) 16 JULY 1991 (16.07.91), see entire document.	1-11
Y	US 5,256,371 A (M. PIPPERT) 26 OCTOBER 1993 (26.10.93), see entire document.	5-11
Y	US 4,596,549 A (H. MINAMI) 24 JUNE 1986 (24.06.86), see entire document.	5-11, 42-46
Y	US 5,268,144 A (K. HEILMANN ET AL) 07 DECEMBER 1993 (07.12. 93), see entire document.	5-9, 11
Y	US 3,871,913 A (S. SHALDON) 18 MARCH 1975 (18.03.75), see entire document.	5-11
Y	US 4,728,496 A (P.A. PETERSEN ET AL) 01 MARCH 1988 (01.03.88), see entire document.	5-11
X	US 4,695,385 A (J.T. BOAG) 22 SEPTEMBER 1987 (22.09.87), see entire document.	12-14, 17
Y		58-62
Y	US 4,610,782 A (B. TERSTEEGEN ET AL) 09 SEPTEMBER 1986 (09.09.86), see entire document.	39-41
Y	US 3,669,880 A (L.B. MARANTZ ET AL) 13 JUNE 1972 (13.06.72), see entire document.	39-41
Y	US 5,011,607 A (T. SHINZATO) 30 APRIL 1991 (30.04.91), see entire document.	42-46, 63-68
Y	US 5,247,434 A (B.A. PETERSON ET AL) 21 SEPTEMBER 1993 (21.09.93), see entire document.	42-46, 63-68
Y	US 4,978,453 A (R.J. LEONARD) 18 DECEMBER 1990 (18.12.90), see entire document.	42-46
Y	US 4,834,888 A (H.D. POLASCHEGG) 30 MAY 1989 (30.05.89), see entire document.	49-51, 53-55, 57
Y	US 5,064,529 A (S. HIRAYAMA ET AL) 12 NOVEMBER 1991 (21.11.91), see entire document.	49-57
Y	US 5,100,554 A (H.D. POLASCHEGG) 31 MARCH 1992 (31.03.92), see entire document.	58

INTERNATIONAL SEARCH REPORT

International application No.
PCT/US96/01885

C (Continuation). DOCUMENTS CONSIDERED TO BE RELEVANT		
Category*	Citation of document, with indication, where appropriate, of the relevant passages	Relevant to claim No.
Y	US 5,110,477 A (D.B. HOWARD ET AL) 05 MAY 1992 (05.05.92), see entire document.	58-62
Y	US 4,222,869 A (I. KATO) 16 SEPTEMBER 1980 (16.09.80), see entire document.	63-69
Y	US 5,354,466 A (T. YUNOKI) 11 OCTOBER 1994 (11.10.94), see entire document.	63-69
Y	US 4,769,150 A (J.M. RAMSTACK) 06 SEPTEMBER 1988 (06.09.88), see entire document.	65-69

INTERNATIONAL SEARCH REPORT

International application No.
PCT/US96/01885

Box I Observations where certain claims were found unsearchable (Continuation of item 1 of first sheet)

This international report has not been established in respect of certain claims under Article 17(2)(a) for the following reasons:

- 1. Claims Nos.:
because they relate to subject matter not required to be searched by this Authority, namely:

- 2. Claims Nos.:
because they relate to parts of the international application that do not comply with the prescribed requirements to such an extent that no meaningful international search can be carried out, specifically:

- 3. Claims Nos.:
because they are dependent claims and are not drafted in accordance with the second and third sentences of Rule 6.4(a).

Box II Observations where unity of invention is lacking (Continuation of item 2 of first sheet)

This International Searching Authority found multiple inventions in this international application, as follows:

Please See Extra Sheet.

- 1. As all required additional search fees were timely paid by the applicant, this international search report covers all searchable claims.
- 2. As all searchable claims could be searched without effort justifying an additional fee, this Authority did not invite payment of any additional fee.
- 3. As only some of the required additional search fees were timely paid by the applicant, this international search report covers only those claims for which fees were paid, specifically claims Nos.:

- 4. No required additional search fees were timely paid by the applicant. Consequently, this international search report is restricted to the invention first mentioned in the claims; it is covered by claims Nos.:

Remark on Protest

- The additional search fees were accompanied by the applicant's protest.
- No protest accompanied the payment of additional search fees.

INTERNATIONAL SEARCH REPORT

International application No.
PCT/US96/01885

A. CLASSIFICATION OF SUBJECT MATTER:
IPC (6):

B01D 17/00, 17/09, 17/12, 24/46, 24/48, 35/18, 36/00, 36/04, 37/00, 41/00, 61/00, 61/08, 61/24, 61/26, 61/28, 61/30, 61/32, 63/00, 65/00, 65/02, 65/08, 65/10, 71/00; A61L 2/00, 2/24; A61M 1/14; B01F 1/00, 3/00; B08B 3,00, 9/00; B67C 9/00; G06F 3/00; G08B 29/00; G08C 19/00; G09F 3/00

A. CLASSIFICATION OF SUBJECT MATTER:
US CL :

73/37, 38; 137/1, 13, 87, 337, 341, 625; 210/85, 86, 90, 97, 101, 108, 117, 137, 194, 195.1, 195.2, 200, 201, 232, 252, 256, 257.1, 321.65, 321.69, 321.71, 321.72, 411, 412, 417, 418, 636, 645, 646, 647, 649, 650, 651, 739, 741, 742, 764, 767, 774, 791, 797, 798, 805; 215/DIG 3, 230, 247, 264, 321, 329, 354; 235/94R, 123, 449, 450, 462; 364/413.01, 496, 709.06; 422/1, 63, 101, 102, 104, 113, 117, 285; 604/4, 5, 28

B. FIELDS SEARCHED

Minimum documentation searched
Classification System: U.S.

73/37, 38; 137/1, 13, 87, 337, 341, 625; 210/85, 86, 90, 97, 101, 108, 117, 137, 194, 195.1, 195.2, 200, 201, 232, 252, 256, 257.1, 321.65, 321.69, 321.71, 321.72, 411, 412, 417, 418, 636, 645, 646, 647, 649, 650, 651, 739, 741, 742, 764, 767, 774, 791, 797, 798, 805; 215/DIG 3, 230, 247, 264, 321, 329, 354; 235/94R, 123, 449, 450, 462; 364/413.01, 496, 709.06; 422/1, 63, 101, 102, 104, 113, 117, 285; 604/4, 5, 28

BOX II. OBSERVATIONS WHERE UNITY OF INVENTION WAS LACKING

This ISA found multiple inventions as follows:

This application contains the following inventions or groups of inventions which are not so linked as to form a single inventive concept under PCT Rule 13.1. In order for all inventions to be examined, the appropriate additional examination fees must be paid.

Group I, claims 1-4, drawn to a water pre-treatment apparatus having a temperature-controlled mixing valve and a water filtration unit.

Group II, claims 5-18, drawn to method of disinfection of a dialysis machine by circulating heated water through water treatment module, extracorporeal circuit and dialysis circuit, and apparatus for establishing fluid connection between an extracorporeal circuit and a source of disinfection fluids with a disinfection manifold.

Group III, claims 19-21, drawn to an apparatus for supplying a batch of chemicals stored in multiple vessels to a dialysate tank having a housing with multiple ports and a batch dialysate preparation apparatus having means associated with tank for automatically introducing batch of chemicals from the vessel into the dialysate preparation tank.

Group IV, claims 22-38, drawn to an apparatus having a bottle with a machine-readable indicator and a chemical application system for applying chemicals into a dialysate tank using a bottle with a machine-readable indicator and a method for automatically identifying the contents of a vessel by reading the a machine-readable indicator on the bottle. Group V, claims 39-41, drawn to a method for maintaining separation of old and new dialysate in a batch dialysate preparation tank.

Group VI, claims 42-46, drawn to a method of operating dialyzer in an extracorporeal circuit by pumping a fluid for a brief period through dialyzer membrane from the dialysate side of the membrane to the blood side of the membrane during hemodialysis.

Group VII, claims 47-48, drawn to a method of conducting dialysis by pumping priming fluid from the extracorporeal circuit through the dialyzer to dialysate circuit.

Group VIII, claims 49-57, drawn to a method for automatically testing the integrity of a dialysate filter by pumping air to dialyzer side or blood side of the dialysate filter.

Group IX, claims 58-62, drawn to a method for approximating the sodium clearance of a dialyzer.

Group X, claims 63-69, drawn to an apparatus comprising means for cleaning blood tubing sets and the dialyzer and a method of cleaning a reusable extracorporeal circuit.

The inventions listed as Groups I-X do not relate to a single inventive concept under PCT Rule 13.1 because, under PCT Rule 13.2, they lack the same or corresponding special technical features for the following reasons:

Unity lacks between Group I and any one of Groups II-X because none of Groups II-X shares a common special technical feature in Group I directed to a water pre-treatment apparatus having a temperature-controlled mixing valve and a water filtration unit. Unity lacks between Group II and any one of Groups I and III-X because none of Groups I and III-X shares a common special technical feature in Group II directed to disinfection of a dialysis machine by circulating heated water through water treatment module, extracorporeal circuit and dialysate circuit using disinfection

INTERNATIONAL SEARCH REPORT

International application No.
PCT/US96/01885

manifold.

Unity lacks between Group III and any one of Groups I-II and IV-X because none of Groups I-II and IV-X shares a common special technical feature in Group III directed to a batch dialysate preparation apparatus.

Unity lacks between Group IV and any one of Groups I-III and V-X because none of Groups I-III and V-X shares a common special technical feature in Group IV directed to an apparatus, an chemical application system and a method using a bottle with a machine-readable indicator.

Unity lacks between Group V and any one of Groups I-IV and VI-X because none of Groups I-IV and VI-X shares a common special technical feature in Group V directed to method for maintaining separation of old and new dialysate in a batch dialysate preparation tank.

Unity lacks between Group VI and any one of Groups I-V and VII-X because none of Groups I-V and VII-X shares a common special technical feature in Group VI directed to a method for operating a dialyzer in an extracorporeal circuit by pumping fluid for a brief period through dialyzer membrane from the dialysate side of the membrane to the blood side of the membrane. Unity lacks between Group VII and any one of Groups I-VI and VIII-X because none of Groups I-VI and VIII-X shares a common special technical feature in Group VII directed to a method of conducting dialysis by pumping priming fluid from the extracorporeal circuit through the dialyzer to the dialysate circuit.

Unity lacks between Group VIII and any one of Groups I-VII and IX-X because none of Groups I-VII and IX-X shares a common special technical feature in Group VIII directed to a method for automatically testing the integrity of a dialysate filter by pumping air to dialyzer side or blood side of the dialysate filter.

Unity lacks between Group IX and any one of Groups I-VIII and X because none of Groups I-VIII and X shares a common special technical feature in Group IX directed to a method for approximating the sodium clearance of a dialyzer.

Unity lacks between Group X and any one of Groups I-IX because none of Groups I-IX shares a common special technical feature in Group X directed to an apparatus having means for cleaning blood tubing sets and dialyzer and a method of cleaning a reusable extracorporeal circuit.

**This Page is Inserted by IFW Indexing and Scanning
Operations and is not part of the Official Record**

BEST AVAILABLE IMAGES

Defective images within this document are accurate representations of the original documents submitted by the applicant.

Defects in the images include but are not limited to the items checked:

- BLACK BORDERS**
- IMAGE CUT OFF AT TOP, BOTTOM OR SIDES**
- FADED TEXT OR DRAWING**
- BLURRED OR ILLEGIBLE TEXT OR DRAWING**
- SKEWED/SLANTED IMAGES**
- COLOR OR BLACK AND WHITE PHOTOGRAPHS**
- GRAY SCALE DOCUMENTS**
- LINES OR MARKS ON ORIGINAL DOCUMENT**
- REFERENCE(S) OR EXHIBIT(S) SUBMITTED ARE POOR QUALITY**
- OTHER:** _____

IMAGES ARE BEST AVAILABLE COPY.

As rescanning these documents will not correct the image problems checked, please do not report these problems to the IFW Image Problem Mailbox.